



OPERATOR'S MANUAL



AM-260 | V1 0220

GeoSystem 260 5 Section Crop Sprayer



ENG All rights reserved. The reproduction of this manual, either totally or partially, in any form whatsoever, whether on paper or through computer processes, is strictly prohibited.

GEOline Electronic S.r.l. and the team involved in the preparation of this manual will not be held responsible for any problem arisen as a result of improper use of this manual, as they guarantee that the information contained in it has been subjected to careful inspection. The products are continuously checked and improved. For this reason GEOline Electronic S.r.l. reserves the right to modify the information contained in this manual without prior notice.

GEOline Electronic S.r.l. Team

1 INDEX

1	INDEX	1
2	INTRODUCTION	2
3	LEGEND	3
4	INTENDED USE	3
5	WARNING	4
6	PACKAGE CONTENT	5
7	DIMENSIONS	7
8	ACCESSORIES	7
9	TECHNICAL DATA	8
10	INSTALLATION OF COMPONENTS	9
	10.1 CONFIGURATIONS	9
	10.2 CONNECTIONS SCHEME	13
	10.3 COMPUTER INSTALLATION	15
	10.4 SPEED SENSOR INSTALLATION	15
	10.5 FOAM MARKER CONNECTION	16
	10.6 FLOWMETER INSTALLATION	16
	10.7 DRIVER BOX W INSTALLATION	17
	10.8 DRIVER BOX H INSTALLATION	21
	10.9 CHECK HARDWARE INSTALLATION	23
	10.10 CHEMICAL COMPATIBILITY	23
11	INTERFACE DESCRIPTION OF INDICATOR	24
	11.1 TABLE LIST OF BUTTONS AND SWITCHES AND THEIR FUNCTIONS	24
	11.2 MENU STRUCTURE	26
	11.3 CONFIGURATION GENERAL PARAMETERS	28
	11.4 CONFIGURATION WORKING PARAMETERS	40
	11.5 WAY OF CALIBRATION AND SPRAYING BOOMS CONFIGURATION	43
	11.6 VALUE OF SOFTWARE PARAMETERS	46
	11.7 WIDTH SECTION	49
12	HW TEST	50
13	USE OF GEOSYSTEM 260	53
	13.1 DISPLAY	53
	13.2 DEFINITION OF TREATMENT	53
	13.3 NEW TREATMENT	54
	13.4 TURNING ON GeoSystem 260	54
	13.5 TURNING OFF GeoSystem 260	56
	13.6 AUTOMATIC FUNCTIONING	56
	13.7 MANUAL FUNCTIONING	57
	13.8 TANK REPLENISHMENT DURING A TREATMENT	57

13.9	HYSTORICAL TREATMENTS	58
13.10	RECALL DATA OF TREATMENTS	59
14	ALARMS	60
14.1	WARNING AND ALARMS	60
14.2	LIST OF POSSIBLE ALARMS	60
15	TROUBLESHOOTING	62
16	OTHER CONFIGURATIONS	63
16.1	EXEMPLE OF GeoSystem 260 5W CS INSTALLATION ON SPRAYER SYSTEM WITH 4 SECTIONS	63
17	DICHIARAZIONE DI CONFORMITA' UE EU DECLARATION OF CONFORMITY EU KONFORMITÄTSEKTLÄRUNG DÉCLARATION UE DE CONFORMITÉ DECLARACION UE DE CONFORMIDAD EU ДЕКЛАРАЦИЯ О СООТВЕТСТВИИ	67
18	GUARANTEE	68
19	ISO TABLE	69
20	ATR TABLE	70
21	MGA TABLE	70
	"QUICK REFERENCE" GEOSYSTEM 260 CS	71
	DISPLAY VISUALIZATION	72
	ALARMS	72

2 INTRODUCTION

Congratulations Dear User,

You have chosen a product by GEOline electronic, a leading company in the development and production of electronic systems for agriculture. For years now, the international trade repays our quality, experience, reliability and above all our technological innovation indicating an advanced and revolutionary know how. These are the pillars of our work and according to these beliefs we are at your service, providing you a simple but modern, accurate and efficient product that supports you in making your work easier for more years. This users manual intends to take you through the different performances of the weighing system in the easiest way and to show you some new functions as well. From configuration to use with several optional at your disposal up to the service of defective research and to security norms on equipments, GEOline electronic would not forget any information, sure to offer you more support and technical assistance.

Now there is nothing left for us to do but wish you a work well done!

The team of GEOline electronic

3 LEGEND

This user's manual uses some conventional signs, in order to lead the user during the reading of important instructions and advices; these concern especially the setting of the parameters of the system and thus its correct working. Please pay attention to the following icons:

	It indicates further explaining and information.
	It highly recommends to pay attention.
	It indicates an operation that can be repeated many times, cyclically.
	It indicates the norms to respect.

4 INTENDED USE

Management system of distribution designed to work on agricultural machinery for spraying and crop spraying applications. The accurate control of the operating parameters of the system sprayer or Spraying sprayer increases the effectiveness and efficiency of the treatments, reducing the wastage of chemicals.

5 WARNING



The power supply must be connected directly to the battery or to a regulated feeder.

The power supply must be protected with a 10A fuse.

If it is not the case, GEOline electronic is not responsible for damages to the micro computer.



Disconnect the power supply cable from the micro computer when the battery is undergoing recharge.

If it is not the case, GEOline electronic is not responsible for damages to the micro computer.



Disconnect all lines from the local plant before undertaking welding on the vehicle.

If it is not the case, GEOline electronic is not responsible for damages to the micro computer.



For a correct functioning, please make sure that the battery has always a higher voltage than 10,5 Volt.



Before cleaning the agricultural vehicle with high pressure water jets, protect the equipment from any possible water entrance. In addition, take great care not to subject the devices, cables or any options to direct jets of water.



If the equipment needs to be cleaned, use a soft, damp, lint-free cloth. Do not use sprays, solvents, abrasives, or sharp or pointed objects that could damage the indicator.

ENVIRONMENT: Disposal Rules



This marking on the product or on its packaging means that this product can not be disposed with normal household waste. You are responsible for disposal of this equipment in a correct way and in accordance to local regulations.

Electronic equipment, which has become useless, must be collected separately and sent to an eco-reuse.

It is forbidden to abandon in the environment device components or spare parts.

The manufacturer declines any responsibility for possible damage to environment, resulting from non-compliance with the existing legislation regarding disposal / recovery.



6 PACKAGE CONTENT

6.1 GeoSystem 260 Spraying version 3/4/5/7 sections

Kit GeoSystem 260 CS 3W	
Description	Qty
Indicator GeoSystem 260 CS 3W	1
Driver Box W	1
Power cable L=3.5 m+ Com cable L=5 m	1
Valve cable Type B L=1.2 m	5
Foam Maker adapter cable L=0.4 m	1
Speed sensor with cable L=5 m	1
Fixing Support	1

Kit GeoSystem 260 CS 4W	
Description	Qty
Indicator GeoSystem 260 CS 4W	1
Driver Box W	1
Power cable L=3.5 m+ Com cable L=5 m	1
Valve cable Type B L=1.2 m	6
Foam Maker adapter cable L=0.4 m	1
Speed sensor with cable L=5 m	1
Fixing Support	1

Kit GeoSystem 260 CS 5W	
Description	Qty
Indicator GeoSystem 260 CS 5W	1
Driver Box W	1
Power cable L=3.5 m+ Com cable L=5 m	1
Valve cable Type B L=1.2 m	7
Foam Maker adapter cable L=0.4 m	1
Speed sensor with cable L=5 m	1
Fixing Support	1

Kit GeoSystem 260 CS 7W	
Description	Qty
Indicator GeoSystem 260 CS 2W	1
Driver Box W	1
Power cable L=3.5 m+ Com cable L=5 m	1
Valve cable Type B L=1.2 m	9
Foam Maker adapter cable L=0.4 m	1
Speed sensor with cable L=5 m	1
Fixing Support	1

6.2 Indicator GeoSystem 260 Spraying version 5/7 sections with oil-hydraulic functions (5/7)

Kit GeoSystem 260 CS 5W + 5H		Kit GeoSystem 260 CS 7W + 7H	
Description	Qty	Description	Qty
Indicator GeoSystem 260 CS 5W + 5H	1	Indicator GeoSystem 260 CS 5W + 5H	1
Driver Box W	1	Driver Box W	1
Driver Box H	1	Driver Box H	1
Power cable L=3.5 m+ W Com cable L=5 m	1	Power cable L=3.5 m+ W Com cable L=5 m	1
Water Valve cable Type B L=1.2 m	7	Water Valve cable Type B L=1.2 m	9
Power cable L=3.5 m+ H Com cable L=5 m	1	Power cable L=3.5 m+ H Com cable L=5 m	1
General hydraulic cable	1	General hydraulic cable	1
Oil-hydraulic valve cable L=1.2 m	5	Oil-hydraulic valve cable L=1.2 m	7
Foam Maker adapter cable L=0.4 m	1	Foam Maker adapter cable L=0.4 m	1
Speed sensor with cable L=5 m	1	Speed sensor with cable L=5 m	1
Fixing Support	1	Fixing Support	1

Table 1- Package

7 DIMENSIONS

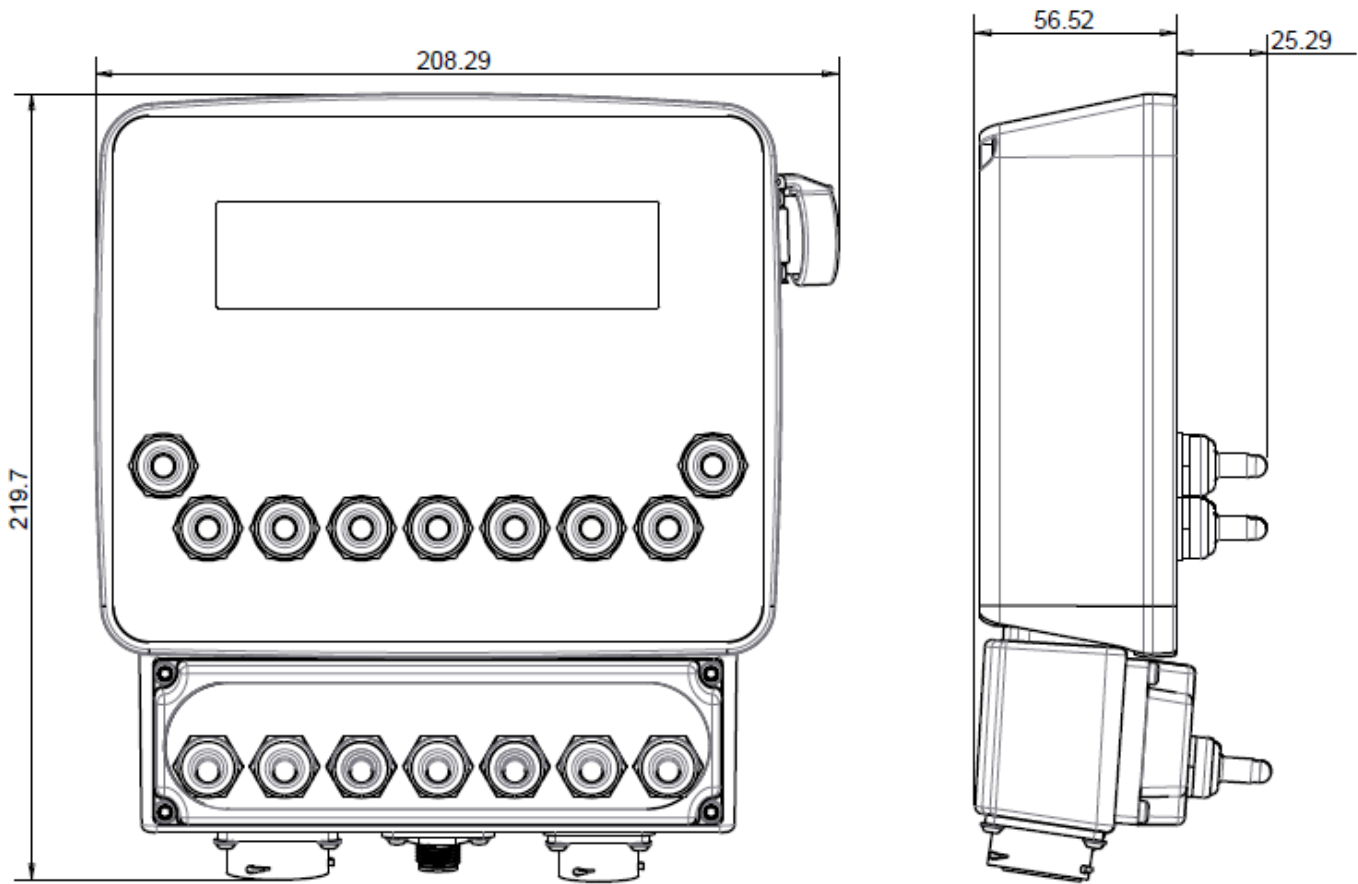

Picture 1 – Dimensions of indicator

8 ACCESSORIES

GeoSystem 260 may be equipped with these accessories:

ACCESSORY	DESCRIPTION
Magnetic Flowmeter	A sensor to noting the flow and to calculate the litres
Paddle Flowmeter	A sensor to noting the flow and to calculate the litres
Pressure Sensor	A sensor to measuring the pressure
Level Sensor	A sensor to measuring the liquid level in the tank
Sucker hangers with mini VESA connection	Hanger to fix in a glass surface
Mobile GPS antenna	Antenna that allows to receive a signal used for determining the location and the velocity of the machine.

Table 2 - Accessories

ENGLISH

9 TECHNICAL DATA

Indicator Dimensions(mm):	192 x 163 x 55 (without fixing support)
Indicator weight (g):	~ 1000
Indicator Case:	PA66+GF 30 % native color RAL 9005
Indicator Protection:	IP 67
Switches Box Dimensions (mm):	167 x 69 x 72
Switches Box Weight (g):	~ 1100
Switches Box Case:	PA66+GF 30 % native color RAL 9005
Switches Box Protection:	IP 67
Valves Driver Box Dimensions (mm):	210 x 130 x 45
Valves Driver Box Weight (g):	~ 1100
Valves Driver Box Case:	Technomelt natural resin
Valves Driver Box fixing support:	Stainless steel AISI 304
Valves Driver Box Protection:	IP 67
Operating temperature:	-20 / +65 °C
Storage temperature:	-20 / +65 °C
Power supply:	9,5 – 32 Vd.c. (alarm “LOW BATTERY” < 9,5 Vdc)
Display:	Graphic display with white backlight – 280x64 pixel
Display view:	> 2 mt
Types of power cables:	Multiwire cable for hydraulic valves
	Multiwire cable for oil-hydraulic valves

Table 3 - Technical Data

10 INSTALLATION OF COMPONENTS

10.1 CONFIGURATIONS

10.1.0 Indicator GeoSystem 260 Spraying version 3/4/5/7 sections

On the front, there are a series of switches that manage the section valves of boom, the general control valve and the switch to increase / decrease the flow and pressure rate. It is envisaged also the manual and automatic regulation of the flow and pressure. The operator sets the value of the liquid sprayed (liters per hectare) and the indicator regulates the volumetric valve depending on the speed of travel and on the active sections.

The operator can act on the regulation switch if he wants to increase or decrease the amount of liquid sprayed.



Picture 2 – Indicator with hydraulic switches

1. ON / OFF key.
2. Series of switches in 2 positions (ON-OFF) to control the general valve and section valves (3 or 4 or 5 or 7 valves). 1 switch with 3 positions (ON-OFF-ON) with spring return in the OFF command for volumetric valve
3. Function and setting key
4. Graphic display with white backlight.

The system is supplied with pre-drilled mounting bracket. It is provided for a MED fastening system (optional) with dedicated accessories.
 The system is able to shore up a maximum load of 2.5 Kg.

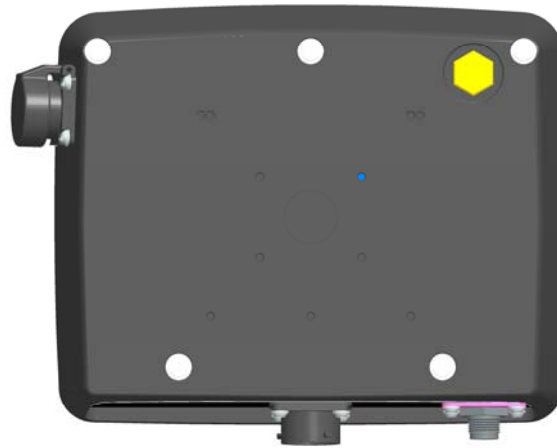

Picture 3 - Back side of the indicator with hydraulic functions



Application zone of self-adhesive labels with production codes, model, and serial number.

10.1.1 Layout of the switches

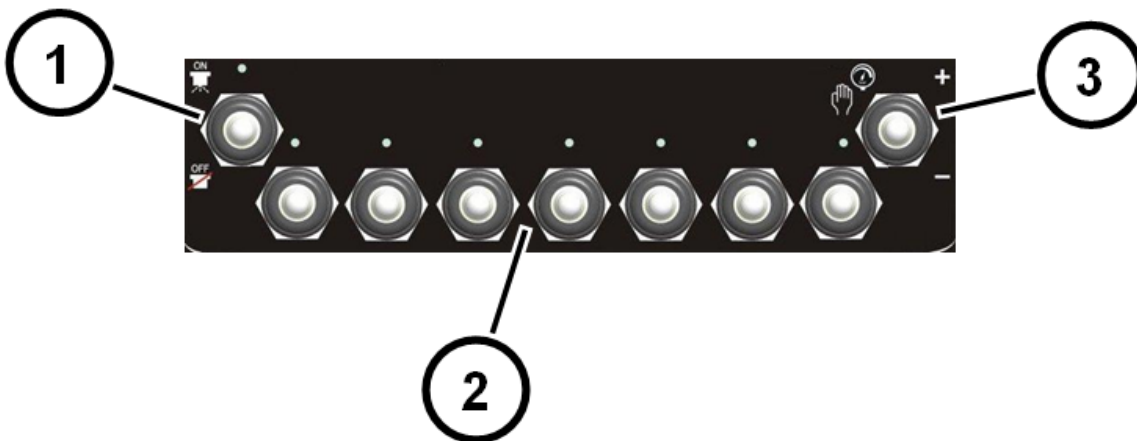

Picture 4 - Layout of the switches

- 1. Control switch of the general valve
- 2. Control switches of the section valves
- 3. Volumetric valve command.

10.1.2 Indicator GeoSystem 260 Spraying version with oil-hydraulic functions

This version has the same functions as the Spraying one with the additional box dedicated to the oil-hydraulic functions.

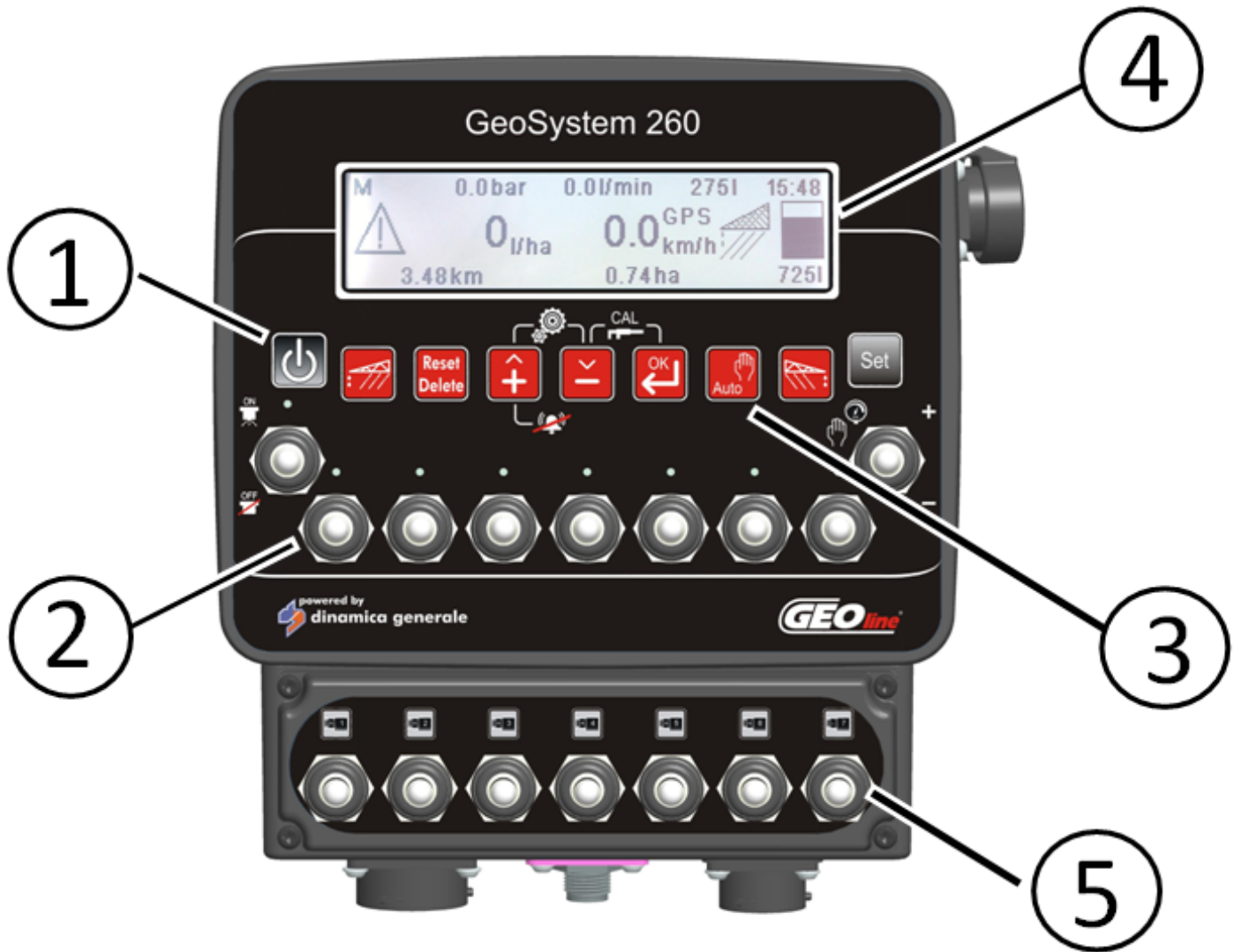

ENGLISH

Picture 5 - Indicator with oil-hydraulic functions

1. ON / OFF key.
2. Series of switches for general valve, section valves and volumetric valve control .
3. Function and setting key.
4. Graphic display with white backlight.
5. Series of switches for oil-hydraulic functions (5/7 functions).

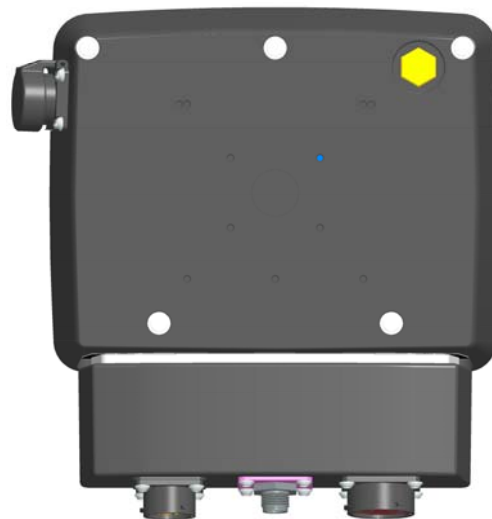

Picture 6 - Back side of indicator with oil-hydraulic functions



Application zone of self-adhesive labels with production codes, model, and serial number.

10.1.3 Layout of the switches



Picture 7 - Layout of the switches, oil-hydraulic version

1. Command switch general valve
2. Command switches of the section valves
3. Volumetric valve command
4. Command oil-hydraulic functions.

10.2 CONNECTIONS SCHEME

10.2.0 Indicator GeoSystem 260 Spraying version 3/4/5/7 sections

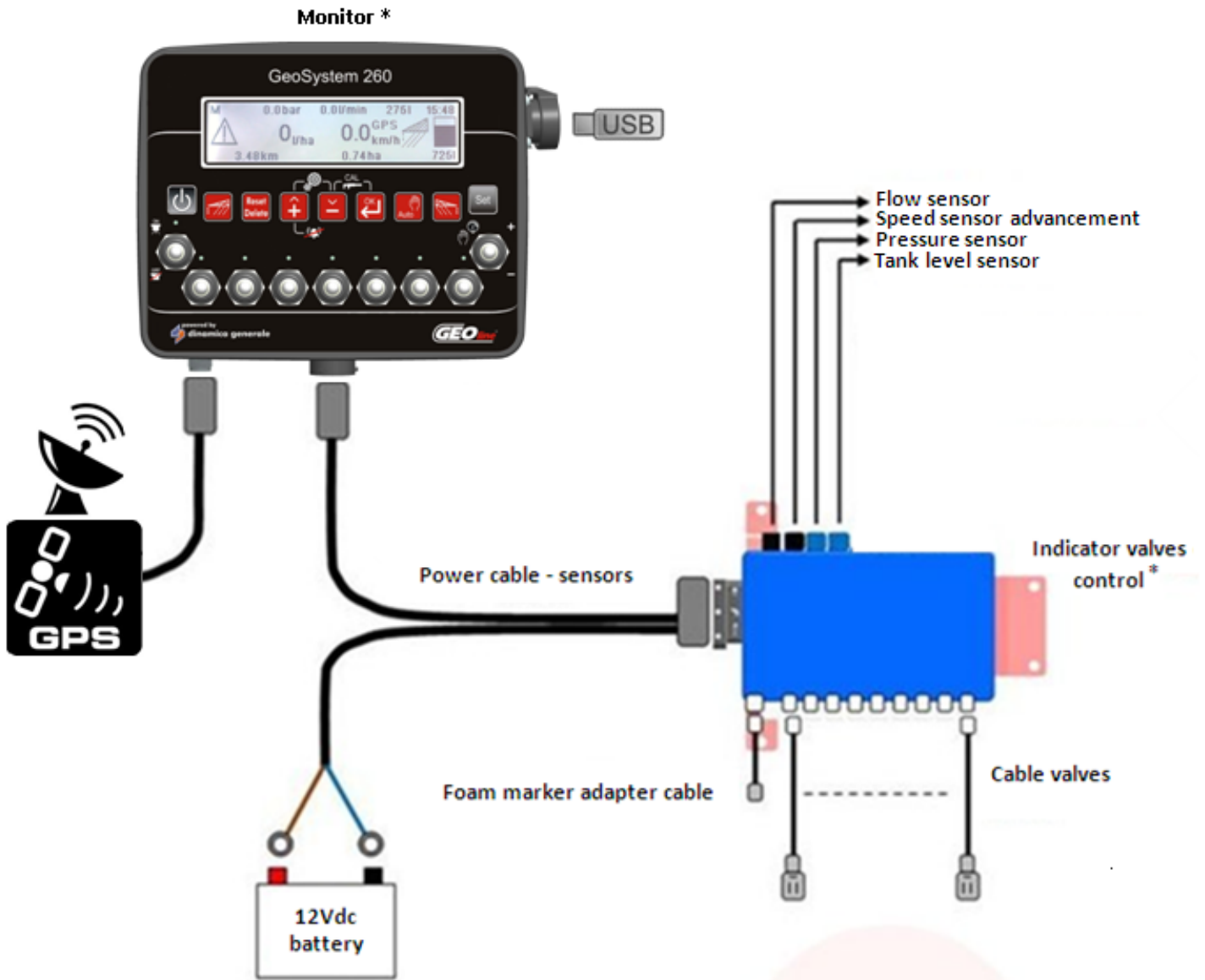

* Reference product configuration table



Picture 8 - Scheme Spraying Version

10.2.1 Indicator GeoSystem 260 Spraying version 5/7 sections with 5/7 switches for oil-hydraulic functions

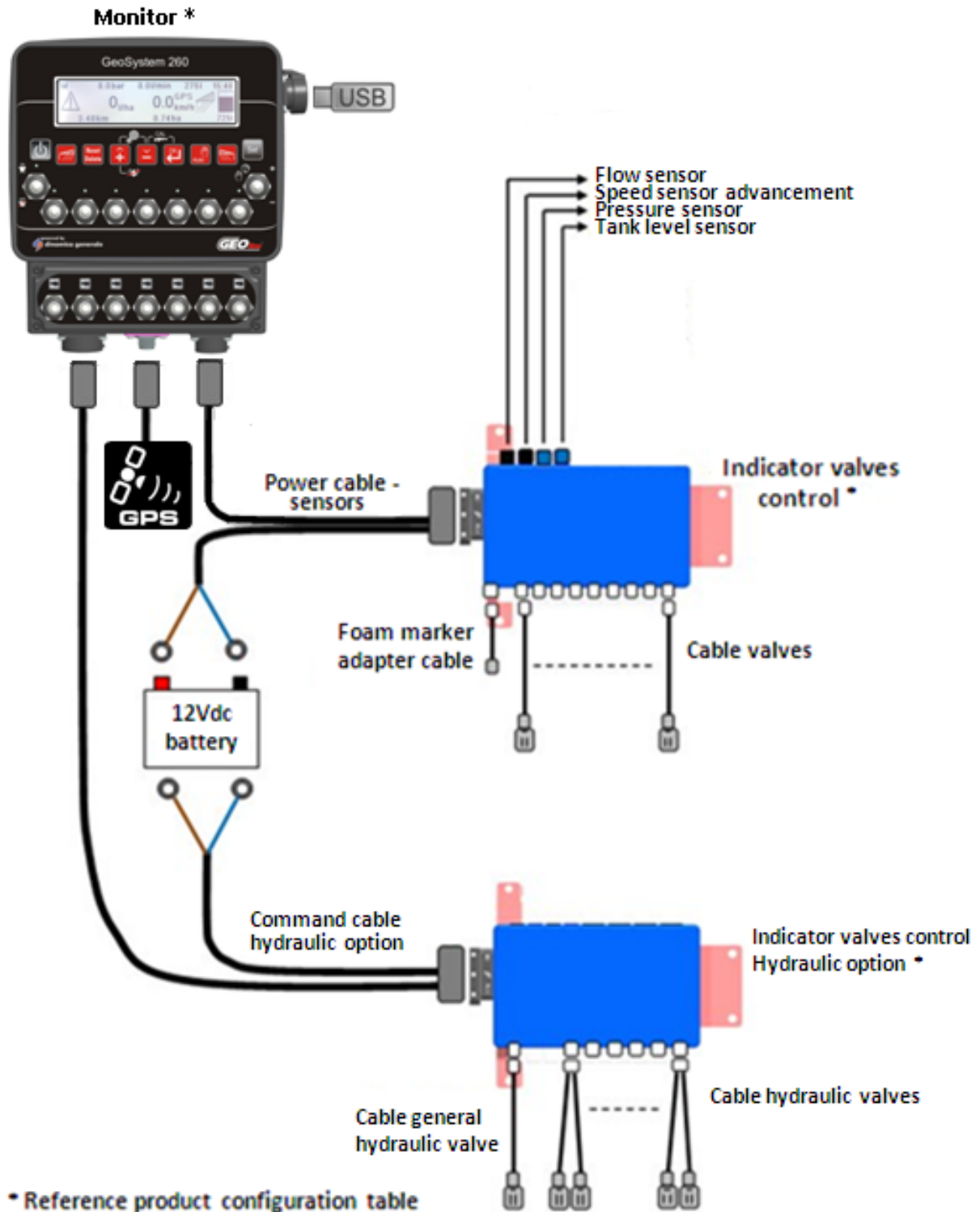

Picture 9 - Scheme oil-hydraulic Version

10.3 COMPUTER INSTALLATION

10.3.0 Advice for the location

The computer GeoSystem must be positioned in the command cabin of the farm vehicle taking care to observe the following precautions:

- Make sure that the monitor is not placed in areas subject to vibrations or crashes, this could damage the equipment or activate the buttons unintentionally.
- Fix the device in a place that is visible and easy to reach with your hands.
- The monitor should not obstruct the movement or limit the control visibility.

10.4 SPEED SENSOR INSTALLATION

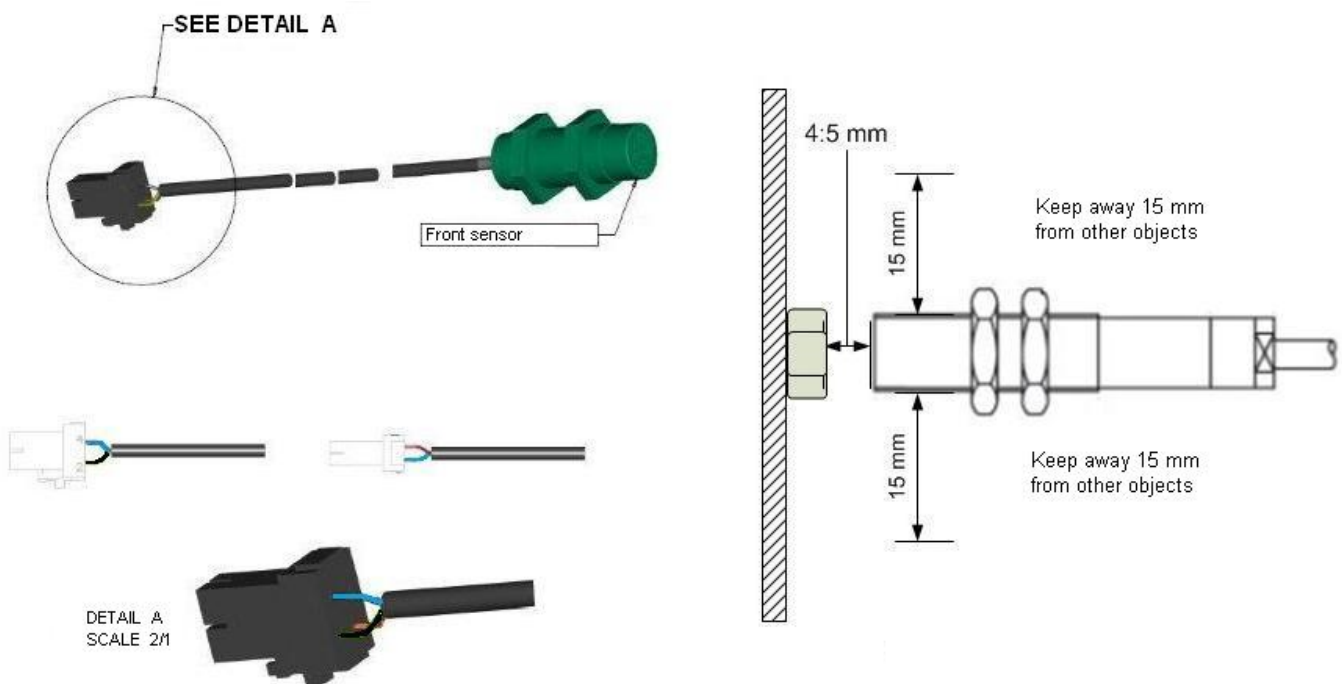

Color	Unsheathe	Termination	Connection point
Blue	30 mm	Stripped 4 mm	4
Brown	30 mm	Stripped 4 mm	1
Black	30 mm	Stripped 4 mm	2

Picture 10 - Proximity Installation

10.4.0 Advice for the location

The speed sensors must be positioned taking care to observe the following precautions:

- Install the sensor at 4-5 mm away from the body to detect;
- Do not install the sensor body too near to other metal objects that may affect the operation of the detector.

10.5 FOAM MARKER CONNECTION

FOAM MARKER

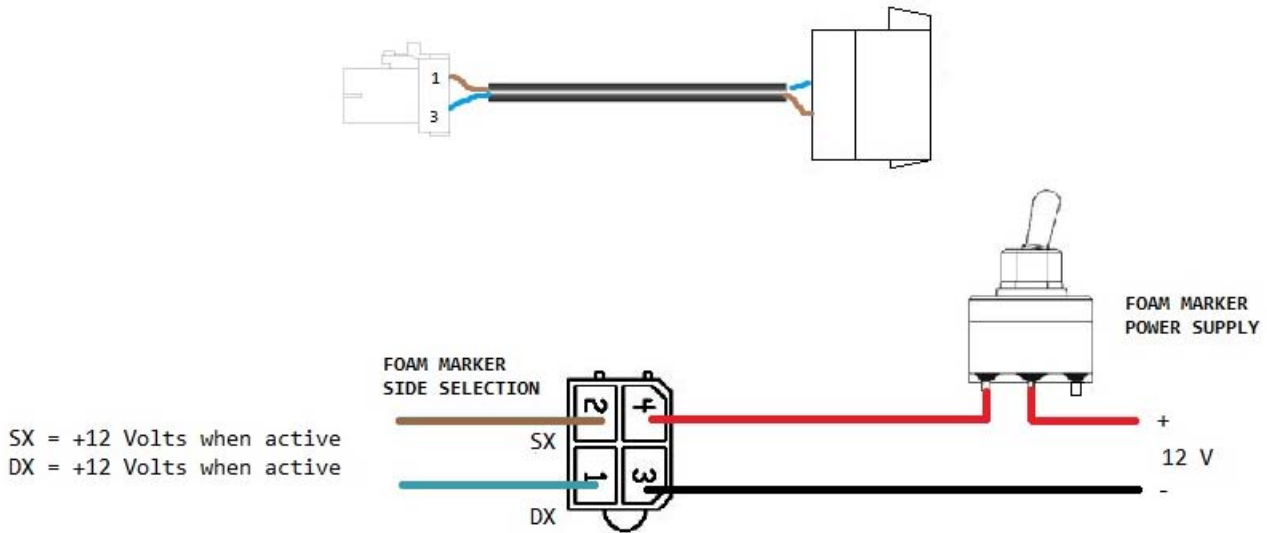

The indicator can not supply directly the foam marker because of its too high power consumption. It is necessary a designed accessory.

Picture 11 - Connection with the Foam Marker

10.6 FLOWMETER INSTALLATION

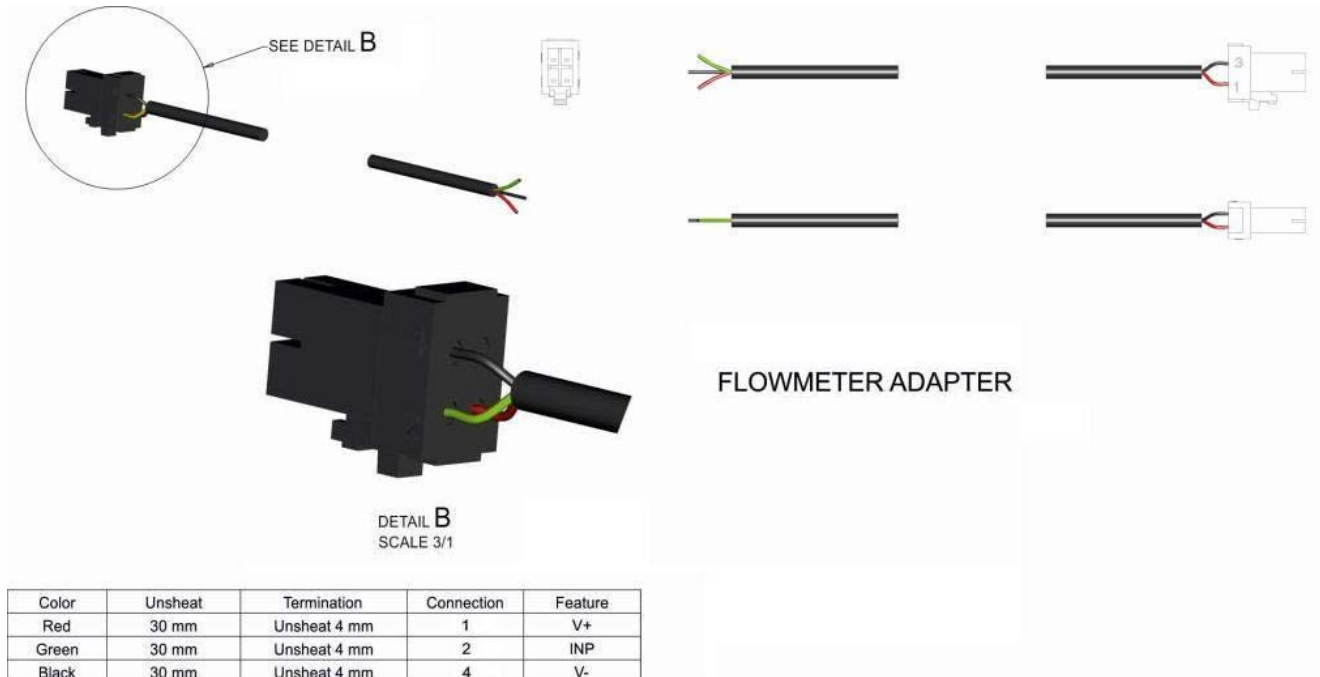

Picture 12 - Flowmeter Installation

10.7 DRIVER BOX W INSTALLATION

10.7.0 Advice for the location

The Driver Box W is installed on the trailer and it also supplies the indicator (located on the cab of the farm vehicle).

The Driver Box W must be connected to a power supply (12Vdc) sufficient to drive the added valves. The connection cable, between the box and the power supply, is long 3,5m and has 2 eyelets M8 on the 2 wires (+ and -).

The power supply must be protected with a 10A fuse.

10.7.1 Cables connecting DRIVER BOX W

The Driver Box W performs the operations to the command valves group. It has a series of interface connectors for sensors and actuators



Picture 13 - Driver Box W

Features:

1. It contains the wiring board with sensors and control outputs for the activation of the solenoid valves 2-wire.
2. This board is connected to the indicator via a multipolar cable 5 meters long.
3. 2 digital inputs (counter NPN):
 - speed sensor (including in the packaging)
 - flowmeter
4. 2 analogical inputs 4-20 mA:
 - pressure sensor of the circuit
 - tank level sensor.

The cable allow to feed the power supply and it presents the signal cables for the communication and the sensor cables.

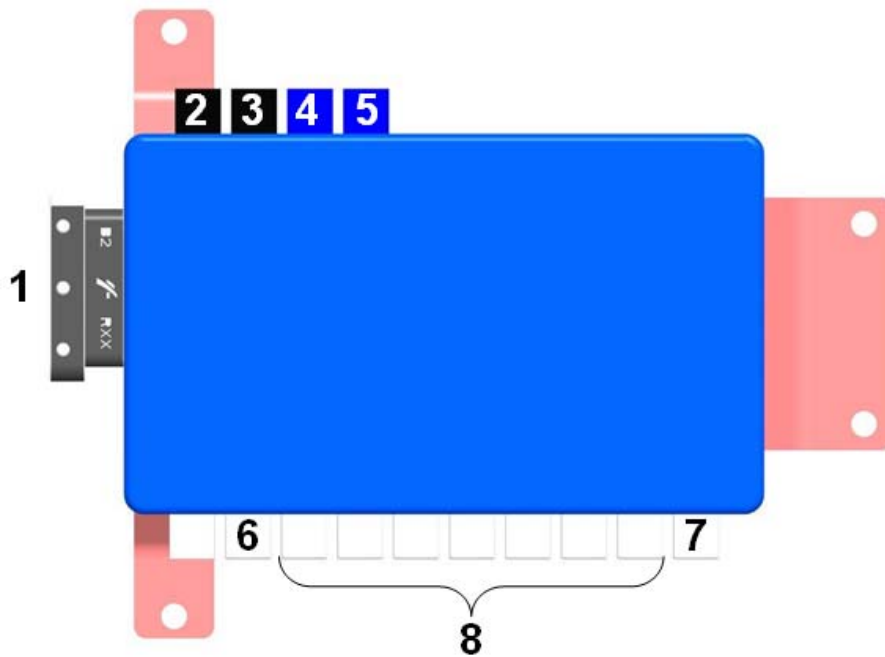
Layout connectors Driver Box W:**Picture 14 - Layout connectors Driver Box W**

- 1. Connector for the supply cable and the cable for the communication with the monitor**
- 2. Connector for the Flowmeter cable**
- 3. Connector for the speed sensor cable**
- 4. Connector for the pressure sensor cable**
- 5. Connector for the tank level sensor cable**
- 6. Connector for the principal valve cable**
- 7. Connector for the proportional valve cable**
- 8. Connectors for command section valves**

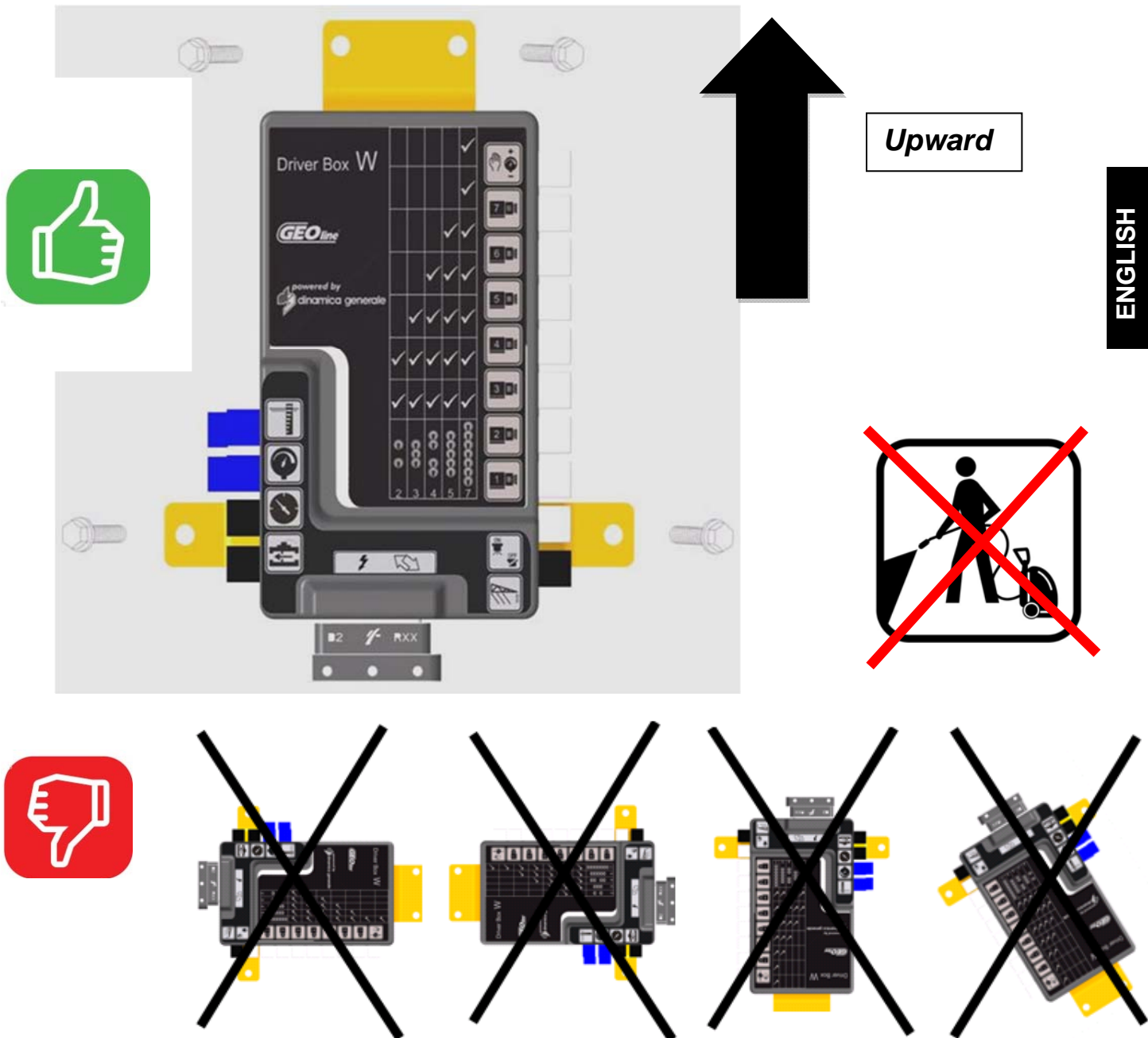

ENGLISH

*The cabling of Input sensors and Output actuators need to be completed before the FCI connector (1) is attached.
Input and Output connectors not used in the specific application should be closed with a closing plug.
Fix driver box on a flat surface applying 4 screws into the predefined holes of the steel plate.*

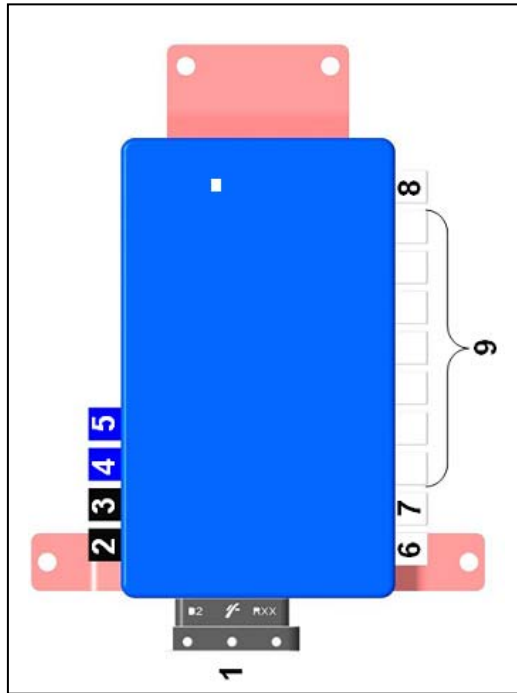

During the installation and the working cycle of the driver box, please be careful not to load up the power-sensor cable with weight. In order to safeguard the connector, the cable should be fixed to a support at a distance of at least 30cm from the connector itself, in order to relieve the weight of the cable.

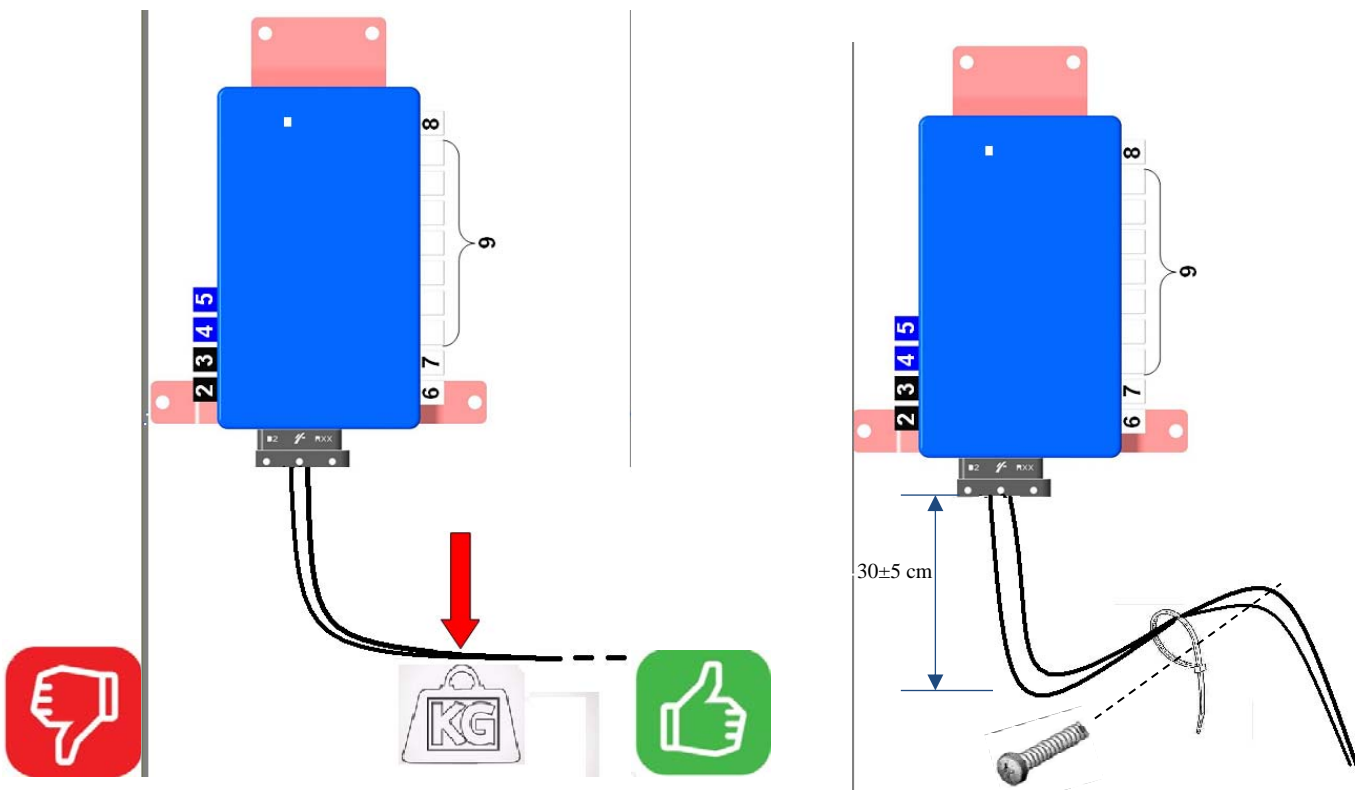

Max current on Input and Output ports.

OUTPUT Section:

$I_{max} = 2.5 A$ for each output port;

INPUT Section:

I_{max} (shared among 4 inputs ports) = 1 A.

10.8 DRIVER BOX H INSTALLATION

10.8.0 Advice for the location

The Driver Box H is installed on the trailer and must be connected to a power supply (12Vdc) sufficient to drive the added valves.

The power supply must be protected with a 10A fuse.

10.8.1 Cables connecting Driver Box H

The Driver Box H of hydraulic valves electrically connects the individual valves to the switch box of command switches.

The box have a relay for piloting the general valve.

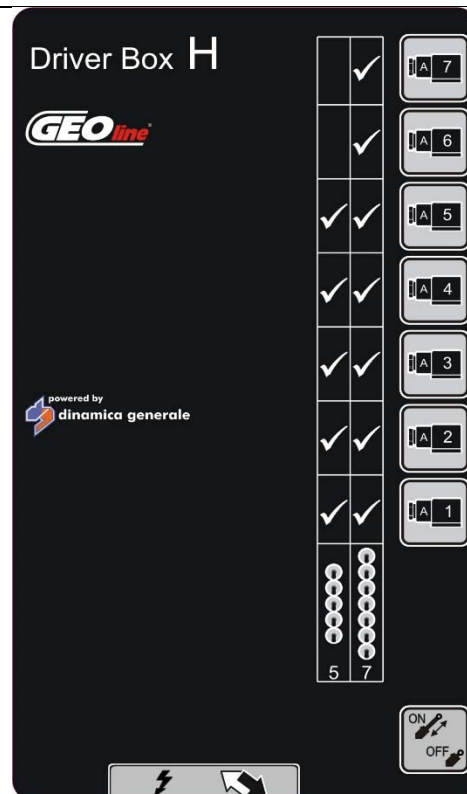

Picture 15 - Driver Box H oil-hydraulic valves

It is expected to manage the oil-hydraulic groups with classic scheme double coil 5/7 valves plus an output for the main valve which is activated in correspondence with any output valves.

The switch box contains the switch command of the oil-hydraulic valves. A series of switches permit to activate the oil-hydraulic valves for the actuation of the individual arms of the spraying boom up to a maximum of 7 sections.

On lower side there is a connector for connecting the supply cable for oil-hydraulic valves and for connecting the cable to the indicator.

Layout connectors Driver Box H:

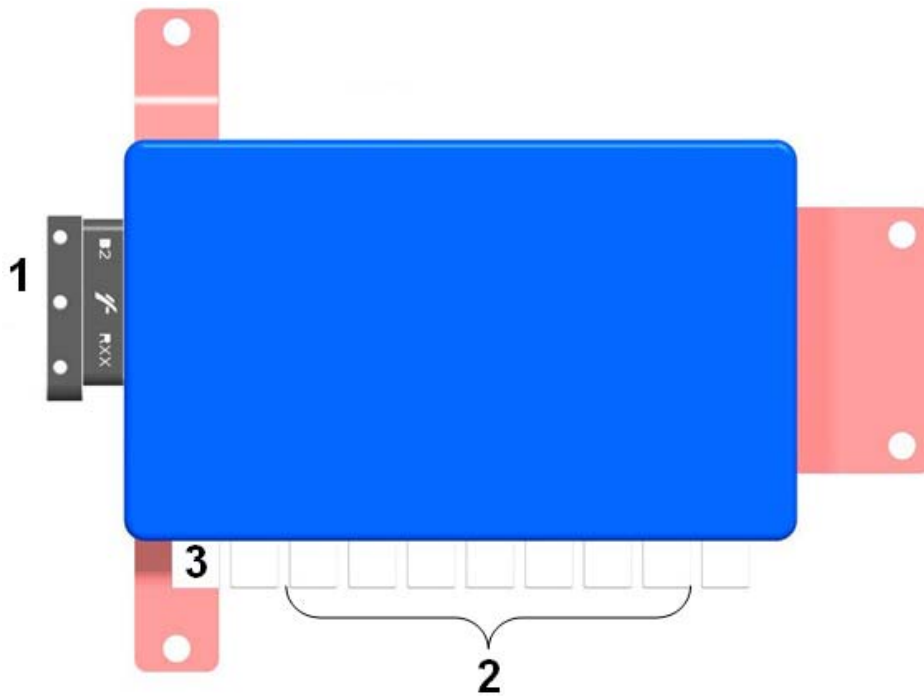

Picture 16 - Layout connectors Driver Box H

1. Connector for the switch box of command oil-hydraulic valves cable and supply cable.
2. Connector for oil-hydraulic valves cables a double coil (4 wires)
3. Connector for general valve (2 wires)

Diagram supported oil-hydraulic valves

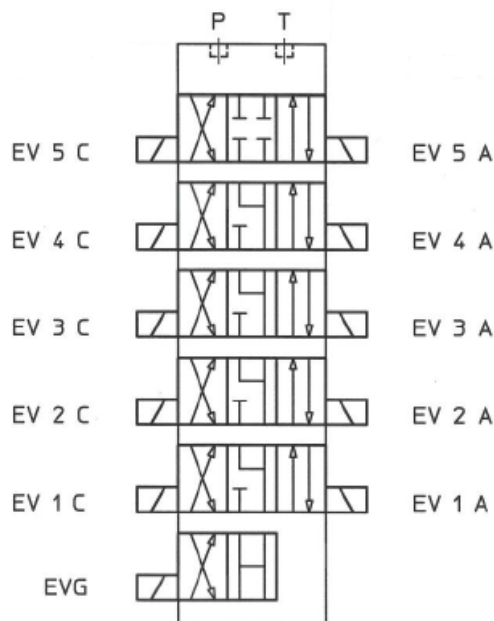

Picture 17 - Scheme oil-hydraulic valves

10.9 CHECK HARDWARE INSTALLATION

Before to start with the use of GeoSystem 260 check the correct installation of each component:

- Check that the connectors are in the right locations
- Check that the cables have the right length
- Check that all screws are tight
- Check the polarity and the supply voltage

GeoSystem must be powered directly from the battery, it must not be connected to an outlet controlled by a master key.



In case of use of groups of valves equipped with a calibrated return, the correct functioning of GeoSystem is guaranteed only by an accurate calibration of all sensors and a proper calibration of the return flows.

10.10 CHEMICAL COMPATIBILITY

The table below shows the chemical compatibility of the Driver BOX material when it is exposed to the following liquids:

LIQUID	CONTACT OR IMMERSION (SHORT TERM EXPOSURE)	IMMERSION (24 h)
OIL	Excellent	Good
BRAKE FLUID	Good	Moderate
DIESEL	Good	Moderate
PETROL	Good	Not Recommended
METHANOL	Good	Not Recommended

Table 4 – Chemical Compatibility

11 INTERFACE DESCRIPTION OF INDICATOR

11.1 TABLE LIST OF BUTTONS AND SWITCHES AND THEIR FUNCTIONS

Monitor with alphanumeric display, buttons and command switches



Picture 18 - Indicator

Command box of oil-hydraulic functions (5/7)



Picture 19 - Oil-hydraulic commands

CONTROL KEYS, SELECTION OR MODIFICATION

ON / OFF key:

Turn on / off the indicator



Activation key foam marker:

Enable / disable the outputs marker on the left side of the vehicle, during the phase of operation (active energy)



Key command:

- Allows to returns to the previous menu
- Resets the percentage of increase / decrease of the value distribution
- Allows to reset the counters of the current treatment



UP key:

- It flows through the individual entries to the previous menu
- Increases the value of the parameter



During the modification of parameters, pressing the button permit to increase quickly the input values

DOWN key:

- Scrolls through the individual items through to the next menu
- Decreases the value of the parameter



During the modification of parameters, pressing the button permit to decrease quickly the input values

Confirm key:

- Confirms the access to the selected menu or parameter value previously modified
- Holding down this button for more than 2 seconds, it permits to display the values of the stored treatments



Command key:

Enable / disable the automatic adjustment of the distribution



Activation key foam marker

Enable / disable the outputs marker on the right side of the medium, during the operation phase (active energy).



Command key:

Allows to enable the menu of the working parameters.



SWITCHES FOR THE CONTROL OF HYDRAULIC FUNCTIONS

Switch for controlling the main valve:

- to open the main valve, slide the switch upwards (LED on)
- to close the main valve, slide the switch downwards (LED off)



Switch for the command of the control valve:

- in order to increasing the amount of liquid to be distributed, place the switch upward

manual function: increase the amount of liquid to be distributed
automatic function: increase the amount of liquid to be distributed at intervals of 10% respect to the set value



- in order to decreasing the amount of liquid to be distributed, place the switch downwards

manual function: decrease the amount of the liquid to be distributed
automatic function: decrease the amount of the liquid to be distributed at intervals of 10% respect to the set value.

11.2 MENU STRUCTURE

GeoSystem 260 menu are shown in the figure, in order to enter in the various items press the buttons or combinations of buttons located on the front panel of the monitor.

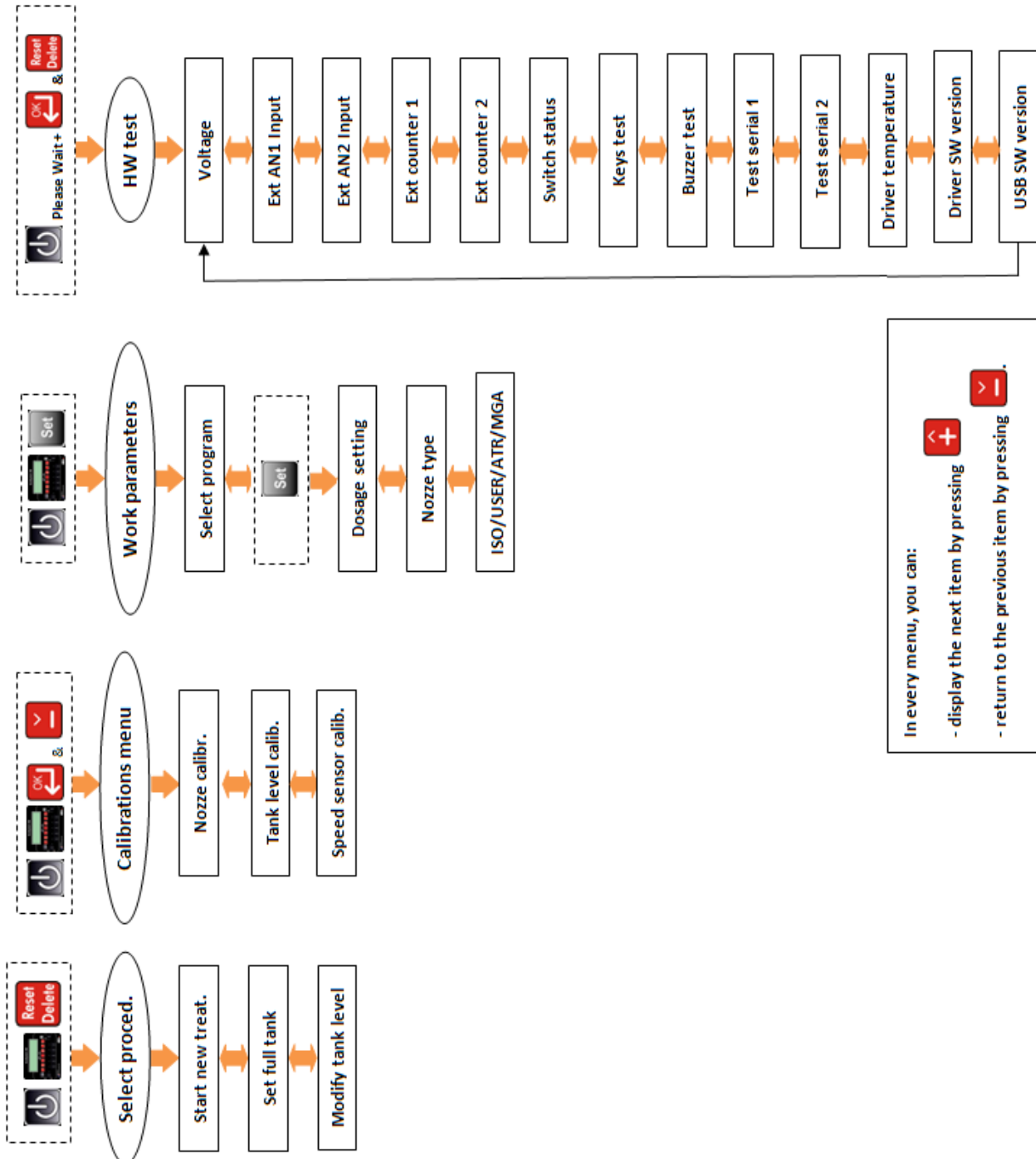

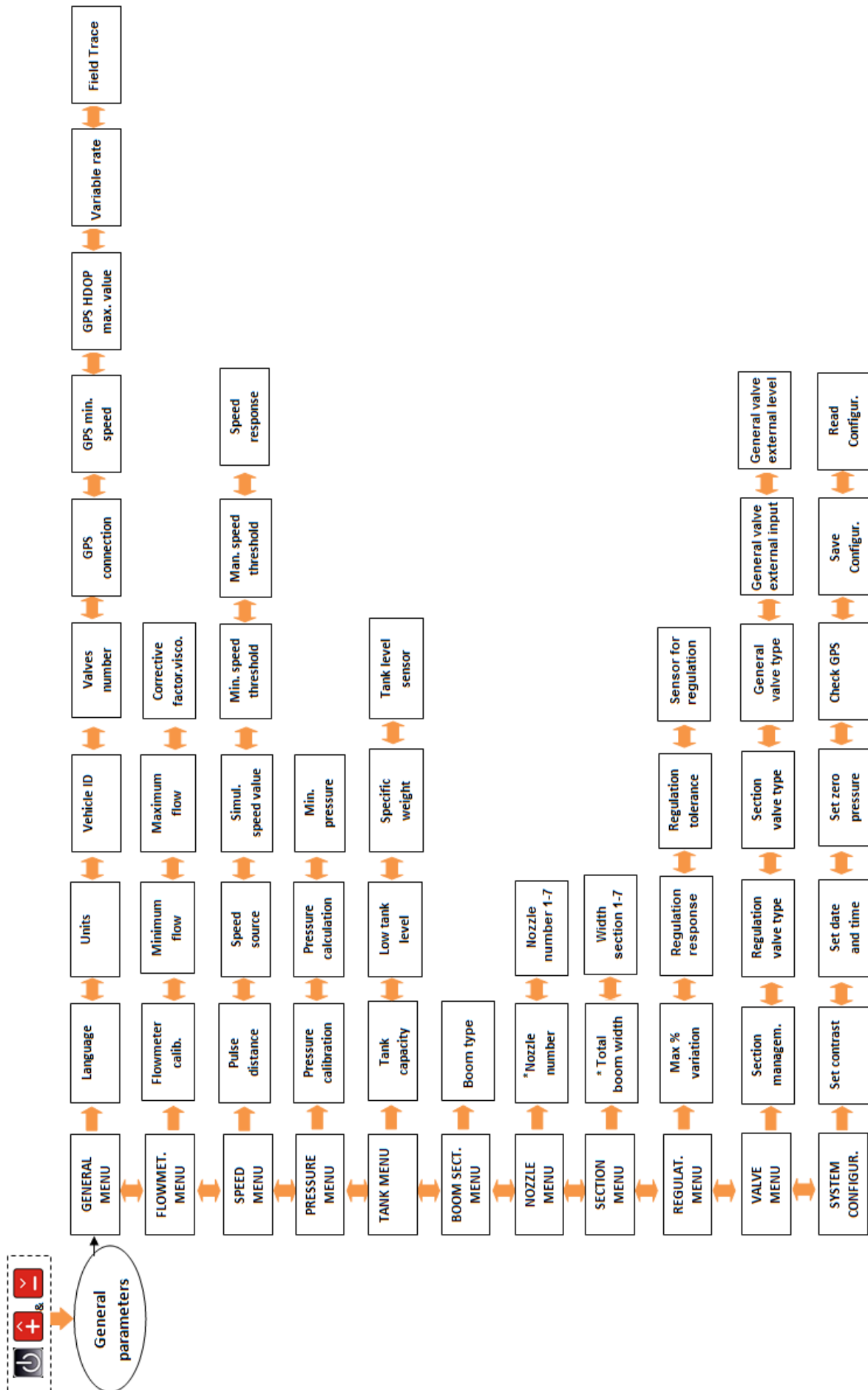

Picture 20 – Menu map

11.3 CONFIGURATION GENERAL PARAMETERS

Allows to set the parameters necessary for the proper operation of the indicator.

1  Turn on by pressing

2 The first message "GEOline Electronic" will appear on the display.



3 Then the message "GEOline GeoSystem 260"



4 It shows the Firmware revision and the system name: Crop Sprayer.





5 Then, it appears the message "Please Wait".





6 The working values appear.

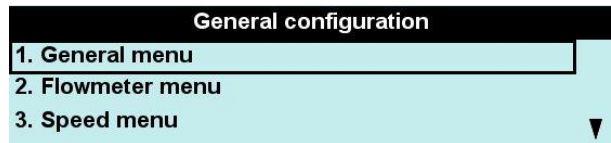

7 Keep pressing simultaneously  and  in order to enter in the general configuration.





8 Scroll through the menu using the  and  keys.





The arrow-shaped object in the bottom right signals the presence of other menu.

9 Press the  key in order to enter in the groups: the parameter are classified in groups based on the application field.

General menu	
Language	English
Units	Metrics
Vehicle ID	1

Through the  and  keys is possible to select the parameter and then change the value.

10 Press the  key in order to enter in the parameter and then press the  and  keys to change the value.

General menu	
Language	English
Units	Metrics
Vehicle ID	1



If the field contains default values or names, they will be displayed recursively by

pressing  and  keys.

If the input value is numeric, it will be increased or decreased according to the duration of the key press with an exponential interval.



It is possible to cancel the current selection or return to the previously menu by

pressing the  key.

11.3.1 LIST OF MENU ITEMS OF GENERAL MENU

1 **Language:**
Italian/English/Spanish/French/German/
Portuguese/ Finnish/Russian/Polish.

General menu	
Language	English
Units	Metrics
Vehicle ID	1

2 **Units:**
Metrics (l/ha, Km/h, bar) / US (GPA,
mph, psi).

General menu	
Language	English
Units	Metrics
Vehicle ID	1

- 3 **Vehicle identification:**
 (1-5) it identifies the vehicle on which the system is installed.



* By entering this configuration, you set the parameters for that particular vehicle (in this example: vehicle 1).

General menu	
Language	English
Units	Metrics
Vehicle ID	<input type="text" value="1"/>

- 4 **Number of section valves:**
 3, 4, 5, 6, 7

General menu	
Valves number	5 ▲
GPS connection	GPS
GPS Minimum Speed	0.5 km/h ▼

- 5 **Type of GPS connection for determining the position:**
 None / GPS RX / AV G6 / TOP Xn
 Topcon / GEOSC1 / TUVR Trimble

General menu	
Valves number	5 ▲
GPS connection	GPS
GPS Minimum speed	0.5 km/h ▼

- 6 **Minimum speed for the GPS tracking:**
 0.0-5.0 Km/h (Metric) o 0.0-3.1 mph (US).
 Below this value, the system considers a zero speed.

General menu	
Valves number	5 ▲
GPS connection	GPS
GPS Minimum speed	0.5 km/h ▼

- 7 **Permissible maximum value for GPS precision:**
 0.0 – 10.0

Above the set value the system will activate an alarm in order to point out that the data related to the position and the speed are unreliable.

General menu	
GPS HDOP max value	2.0 ▲
Variable rate	No
Field Trace	No

- 8 **Variable rate:**
 Yes / No

Select “Yes” in order to enable the possibility of managing the variable distribution value according to the vehicle position.

This feature is only available with a GPS agricultural navigator enabled for this purpose and connected to Geosystem 260 (see the “GPS Connection” parameter).

General menu	
GPS HDOP max value	2.0 ▲
Variable rate	No
Field Trace	No

9 **Field Trace:**

Yes / No

Select "Yes" in order to enable the data exchange through Field Trace Software using the USAB key.

Refer to the manual of Field Trace software for further informations.

General menu		
GPS HDOP max value	2.0	▲
Variable rate	No	
Field Trace	No	

11.3.2 LIST OF MENU ITEMS OF FLOWMETER MENU

1 **Flowmeter calibration:**

It specifies how many pulses arrive to the flowmeter per amount of liquid sprayed.

1-5000 pulse/liter (Metric) or pulse/USG (gallon) (US). The value is indicated in the label on the body or by manufacturer.

Flowmeter menu		
Flowmeter calib	722	imp/l
Minimum flow	0	l/min
Maximum flow	0	l/min ▼

2 **Alarm threshold minimum flow:**

0-10000 l/min (Metric) o USG (gal/min) (US)

Flowmeter menu		
Flowmeter calib	722	imp/l
Minimum flow	0	l/min
Maximum flow	0	l/min ▼

3 **Alarm threshold maximum flow:**

0-10000 l/min (Metric) o USG (gal/min) (US) (l/min).

Flowmeter menu		
Flowmeter calib	722	imp/l
Minimum flow	10000	l/min
Maximum flow	0	l/min ▼

4 **Viscosity corrective factor:**

Value of the corrective factor of the flow in function of the viscosity of the liquid

Flowmeter menu		
Corr.fact.visco.	1.00	▲

11.3.3 LIST OF MENU ITEMS OF SPEED MENU

1 **Pulse distance:**

2 mode: Constant wheel = distance traveled (cm or inches) / number of pulses per revolution or Automatic over a distance of 100 meters it is acquired pulse count.

Speed menu		
Pulse distance	1.3	cm/imp
Speed source	GPS	
Simulated speed val.	0.0	km/h ▼

2 **Speed source:**

- **GPS:** use the GPS antenna or the GPS navigator as source of speed vehicle measure.
- **Prox.:** speed measured through proximity sensor
- **Auto:** use the GPS antenna or the GPS navigator or,

Speed menu		
Pulse distance	1.3	cm/imp
Speed source	GPS	
Simulated speed val.	0.0	km/h ▼

alternatively, the proximity sensor if they are not available.

- **Sim.:** speed simulated

3	Simulated speed value: 0.0-50.0 Km/h (metric) or mph (U.S.)	Speed menu		
		Pulse distance	1.3	cm/imp
		Speed source	GPS	
		Simulated speed val.	0.0	km/h ▼

4	Minimum speed threshold: 0.0-50.0 Km/h (metric) or mph (U.S.). Below this value, it stops the spraying.	Speed menu		
		Min speed thresh	2.3	km/h ▲
		Manual speed thr	6.0	kmh
		Speed response	2	

5	Manual speed threshold: 0.0-50.0 Km/h (metric) or mph (U.S.). Below this value, it is not carried out the automatic management (only manual).	Speed menu		
		Min speed thresh	2.3	km/h ▲
		Manual speed thr	6.0	kmh
		Speed response	2	

6	Sensitivity to change in velocity: it changes the response time of the flow rate control in function of the speed, from the value 1 (fast) to the value 5 (slow). By increasing this value, you will increase the precision but you will reduce the speed variation.	Speed menu		
		Min speed thresh	2.3	km/h ▲
		Manual speed thr	6.0	kmh
		Speed response	2	

11.3.4 LIST OF MENU ITEMS OF PRESSURE MENU

1	Sensor pressure calibration: 0-200 F.S. value (bar or psi).	Pressure menu		
		Pressure calibration	99	bar
		Pressure calcul.	Yes	
		Min. pressure	0	bar

2	Pressure calculation: Yes/No.	Pressure menu		
		Pressure calibration	99	bar
		Pressure calcul.	Yes	
		Min. pressure	0	bar

3	Minimum pressure: 0-200 bar After 30 seconds with a value below the minimum pressure, an alarm is generated.	Pressure menu		
		Pressure calibration	99	bar
		Pressure calcul.	Yes	
		Min. pressure	0	bar

11.3.5 LIST OF MENU ITEMS OF TANK MENU

1	Tank capacity: 0-10000 liter (Metric) or USG (gallon) (US).	Tank menu		
		Tank capacity	1000	l
		Low tank level	100	l
		Specific weight	1.00	▼

- 2 **Alarm threshold minimum tank level:**
0-10000 liter (Metric) or USG (gallon) (US).

Tank menu		
Tank capacity	1000	
Low tank level	100	
Specific weight	1.00	▼

- 3 **Specific weight liquid tank:**
Only if the presence sensor level = YES, it allows to calculate the level of the tank in function of the specific weight of the liquid inside.

Tank menu		
Tank capacity	1000	
Low tank level	100	
Specific weight	1.00	▼

- 4 **Presence level sensor:**
If you choose YES, the measured level is used in the replenishment procedure of the tank. If you choose NO, it shows the pre-setting value.

Tank menu		
Tank leve sens.l	No	▲



If you choose YES, the parameter “Modify tank level” won’t be visualized, because the tank level is measured through the sensor level.

11.3.6 LIST OF MENU ITEMS OF BOOM SETTING MENU

- 1 **Spray boom type:**
Definition of the boom type:
- **Symmetric:** the right and left sections are symmetric. In this case, it is possible to define the dimensions of the individual sections based on the number of valves divided by 2. The dimension of the central section is calculated by difference.
 - **Asymmetric:** the right and left sections are asymmetric. In this case, it is possible to define the dimensions of the individual sections based on the total number of the valves defined.

Boom setting menu	
Boom Type	Symmetr.

11.3.7 LIST OF MENU ITEMS OF NOZZLE MENU

1 Nozzle number:
 Total number of nozzles present on the sprayers.
 0 - 1000

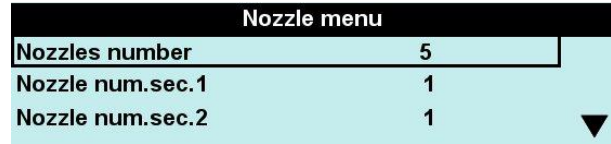

2 Nozzle num. sec.1-7:
 Number of nozzle for each boom section.
 0 – 200



Parameters related to the number of nozzle per section with symmetrical boom configuration:

Number of section:	Number of nozzle section 1	Number of nozzle section 2	Number of nozzle section 3
3	Required	Not Required	Not Required
4	Required	Required	Not Required
5	Required	Required	Not Required
6	Required	Required	Required
7	Required	Required	Required

Table 5 - Number of nozzles per section

Parameters related to the number of nozzle per section with asymmetrical boom configuration:

Number of section:	Number of nozzle section 1	Number of nozzle section 2	Number of nozzle section 3	Number of nozzle section 4	Number of nozzle section 5	Number of nozzle section 6	Number of nozzle section 7
3	Required	Required	Required	Not Required	Not Required	Not Required	Not Required
4	Required	Required	Required	Required	Not Required	Not Required	Not Required
5	Required	Required	Required	Required	Required	Not Required	Not Required
6	Required	Required	Required	Required	Required	Required	Not Required
7	Required	Required	Required	Required	Required	Required	Required

Table 6 - Number of nozzles per section with asymmetric boom

11.3.8 LIST OF MENU ITEMS OF SECTION MENU

- 1 ***Total width of the spray boom:**
0.00- 100.00 mt.

Section menu		
Width boom	10.00	mt
Width section 1	2.00	mt
Width section 2	3.00	mt

- 2 **Partial width of the spray boom sections:**

It allows defining the width of individual sections of the sprayers.

Section menu		
Width boom	10.00	mt
Width section 1	2.00	mt
Width section 2	3.00	mt

More information to paragraph 11.7

Parameters related to individual partial widths with symmetrical boom configuration:

Number of sections:	Partial width 1	Partial width 2	Partial width 3
3	Required	Not Required	Not Required
4	Required	Required	Not Required
5	Required	Required	Not Required
6	Required	Required	Required
7	Required	Required	Required

Table 7 - Parameters individual partial width with symmetric boom

Parameters related to individual partial widths with asymmetrical boom configuration:

Number of sections:	Width of the section 1	Width of the section 2	Width of the section 3	Width of the section 4	Width of the section 5	Width of the section 6	Width of the section 7
3	Required	Required	Required	Not Required	Not Required	Not Required	Not Required
4	Required	Required	Required	Required	Not Required	Not Required	Not Required
5	Required	Required	Required	Required	Required	Not Required	Not Required
6	Required	Required	Required	Required	Required	Required	Not Required
7	Required	Required	Required	Required	Required	Required	Required

Table 8 - Parameters individual partial width with asymmetric boom

*Parameters are present only if the parameter "Boom type" is "Symmetric".

11.3.9 LIST OF MENU ITEMS OF REGULATION MENU

1 Percentage value of the max variation of increasing/decreasing of the flow rate:

10, 20, 30, 40, 50%

During the automatic functioning, it is possible to act on the proportional valve in order to increase/decrease the flow rate at intervals of +/- 10% up to the maximum percentage.

Regulation menu		
Maximum variation	50	%
Regul. response	Auto	
Regulation tolerance	3	%

2 Regulation response:

This parameter allows varying the time of answer of automatic regulation.

- **Auto:** automatic, the system automatically vary the regulation time according to current conditions.
- **Low:** slow response time to regulation. In low mode, the regulation is more accurate but slower to respond to changes.
- **Middle:** medium response time to regulation.
- **High:** fast response time to regulation. In high mode, the system is faster.
- **Custom:** parameter reserved for the manufacturer, do not use this configuration unless specifically indicate.

Regulation menu		
Maximum variation	50	%
Regul. response	Auto	
Regulation tolerance	3	%

2 Percentage value of the display tolerance:

It determines the sensitivity to display. 0 – 20%

Regulation menu		
Maximum variation	50	%
Regul. response	Auto	
Regulation tolerance	3	%

3 Presence of regulation sensors:

Flowmeter / Pressure / Both

Sensor/sensors used for the automatic regulation of the flow rate.

By setting the value “Both”, the calculation will be done based on the pressure sensor ONLY IF the flow rate is under the value set in the parameter “Minimum flow”.

Regulation menu	
Sensor for regulat.	Flowm.

11.3.10 LIST OF MENU ITEMS OF VALVE MENU

1 Section management:

- It is dependent if, by closing the general valve, the other valves are closed; the led are switch off with the switches in any position. By re-activating the general valve, the other valves are re-activated and the switches are in ON position.
- It is free if the section valves stay opened also if the general valve is closed.

Valve menu	
Section management	Free
Regulat. valve type	Bypass
Section valve type	ON-OFF ▼

2 Regulation valve type:
Bypass / Throttling

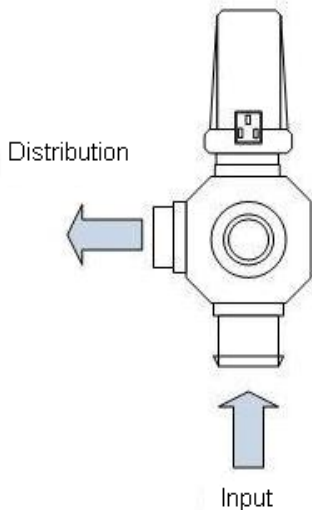

**Regulation valve type:
Throttling for
centrifugal pumps**

Picture 21 - Throttling

Valve menu	
Section management	Free
Regulat. valve type	Bypass
Section valve type	ON-OFF ▼

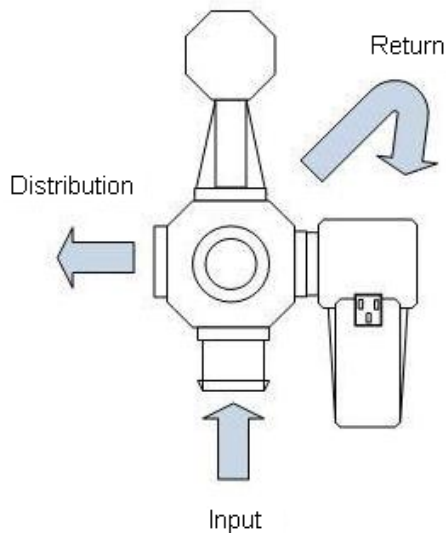

**Regulation valve type:
Bypass with return
to tank**

Picture 22 - Bypass

3 Section valve type:
ON-OFF / Metered

Valve menu	
Section management	Free
Regulat. valve type	Bypass
Section valve type	ON-OFF ▼

4 General valve type
Bypass / Dump

Valve menu	
General valve type	Bypass ▲
Gen.valve ext. input	None
Gen.valve ext. level	Low

5 **Input general valve:**

By connecting an external device to the level sensor connector present on the driver box, it is possible to control opening and closing of the general valve.

- **None:** the general valve can be activated or deactivated by acting only with the diverter on the indicator (normal functioning). It is possible to use the level sensor.
- **AutMan:** by selecting this option, Geosystem 260 can close the general valve depending on the external device connected to the level sensor connector. This feature is enabled both in automatic regulation mode and in manual regulation mode.
- **Auto:** by selecting this option, Geosystem 260 can close the general valve depending on the external device connected to the level sensor connector. This feature is enabled only in automatic regulation mode.
- **Manual:** by selecting this option, Geosystem 260 can close the general valve depending on the external device connected to the level sensor connector. This feature is enabled only in manual regulation mode.

Valve menu	
General valve type	Bypass ▲
Gen.valve ext. input	None
Gen.valve ext. level	Low



To use this mode you must be sure that the level sensor is not present and that the “*Level sensor*” parameter in the “*Tank Menu*” is set to “*No*”.

6 **Activation level of the general valve:**

This parameter defines the activation state of the general valve.

His value is irrelevant if the “*Gen. Valve ext. Input*” is set on “*None*”.

- **Low level:** the general valve is active if the current value measured on the input

Valve menu	
General valve type	Bypass ▲
Gen.valve ext. input	None
Gen.valve ext. level	Low



corresponding to the level sensor is lower than 9 mA.

- **High level:** the general valve is active if the current value measured on the input corresponding to the level sensor is higher than 9 mA.

11.3.11 LIST OF MENU ITEMS OF SYSTEM CONFIGURATION

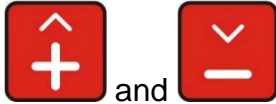
1 Set LCD contrast:



Through the  and  keys is possible to change the contrast value.

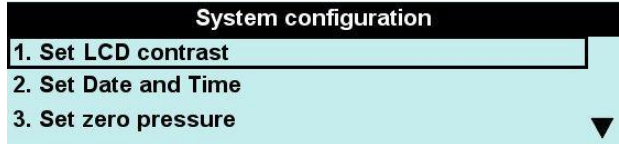

2 Set Date and Time:

Hour-Min/Day-Month-Year

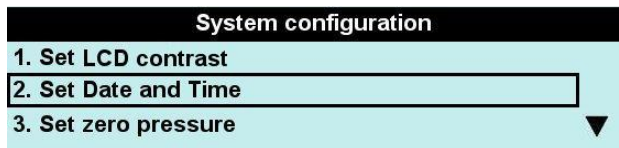

3 Set zero pressure:



Press the  key in order to carry out the pressure calibration procedure. This procedure must be carried out if, without pressure, the displayed value is different from zero.

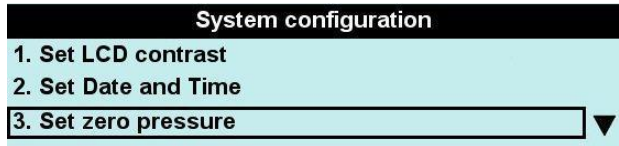

**Set zero pressure:
0.0 bar**

4 Check GPS:



Press the  key in order to run the test for checking the right functioning of the GPS.

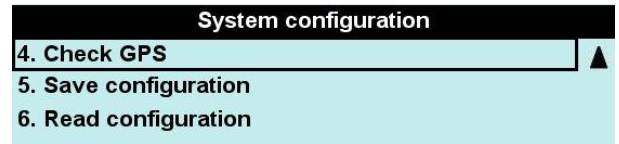

**Press Key OK to
Check GPS**

5 On the display will be shown the following message:

**Test running,
Please wait..**

6 During the test, the indicator will show the following data received from the GPS:

Latitude (LAT) and longitude (LON) of the current position, number of satellites used for detecting the position (SAT), degree of accuracy of the GPS tracking (HDOP) and the type of calculation used to detect the position (FIX).

**LAT: 43.12345678
LON: 11.87654321
SAT: 8 HDOP: 1.2 FIX: 1
Press any key**

The FIX value can be 0 (no detected position), 1 (position detected by the GPS) and 2 (position detected by the DGPS).

- 7 If there is any type of error during the communication with the GPS, the indicator will display the following message:

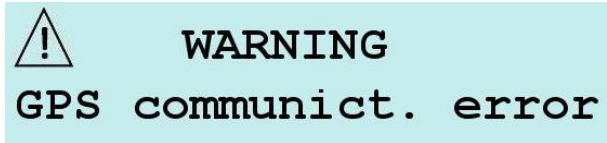

- 8 **Save configuration:**
It allows to save the current values set by the operator on the USB Key.

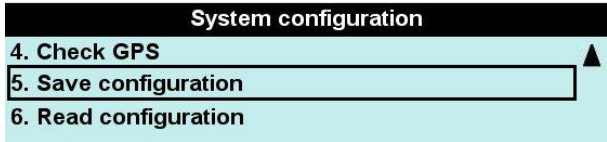

- 9 **Read configuration:**
It allows to read the configuration saved by the operator from the USB Key.

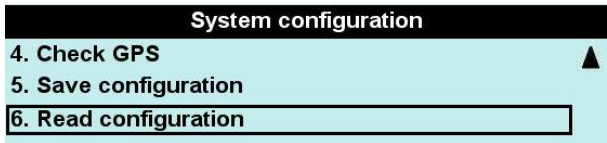

11.4 CONFIGURATION WORKING PARAMETERS

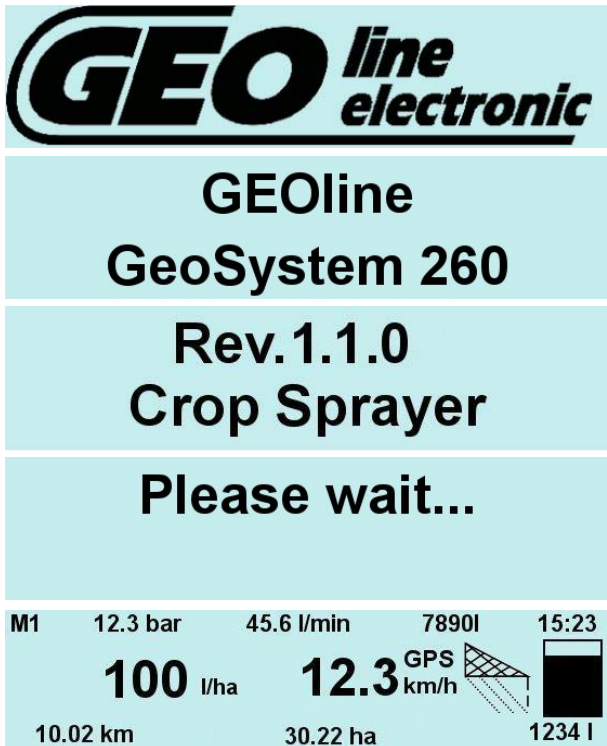

It allows to set all the working parameters of each single vehicle.

- 1 Turn on by pressing .
- 2 The first message "GEOline Electronic" will appear on the display.
- 3 Then the message "GEOline GeoSystem 260"
- 4 It shows the Firmware revision and the system name: Crop Sprayer.
- 5 Then, it appears the message "Please Wait".
- 6 The working values appear.



- 7 Press  key in order to enter in the working selection/configuration menu.



8 Press the  and  keys in order to choose the type of work and confirm pressing  key.



It is possible to configure and choose up to 10 different types of work.

9 Keep pressing again the  key to pass through the following programs.



It is possible to cancel the current selection by pressing  key.

11.4.1 LIST OF ITEMS OF WORKING PARAMETERS

1 **Dosage setting:**
it permits to set the current value of the amount of liquid per unit of surface (liters per hectare).

Work parameters		
Dosage setting	100	l/ha
Nozzle type	ISO	
ISO	ISO-01	

2 Press the  button to enter in the parameter and to set the value using the  and  keys.

3 **Nozzle type:**
The operator can choose between 4 different types of nozzle:
ISO, ATR, MGA or USER
See tables to paragraph 19, 20, 21

Work parameters		
Dosage setting	100	l/ha
Nozzle type	ISO	
ISO	ISO-01	

4 Press the  key to select the type.

5 Select the nozzle using the  and

Work parameters		
Dosage setting	100	l/ha
Nozzle type	ISO	
ISO	ISO-01	



keys.

{0, "ISO-01"},
 {1, "ISO-015"},
 {2, "ISO-02"},
 {3, "ISO-025"},
 {4, "ISO-03"},
 {5, "ISO-04"},
 {6, "ISO-05"},
 {7, "ISO-06"},
 {8, "ISO-08"},
 {9, "ISO-10"},
 {10, "ISO-15"},
 {11, "ISO-20"},

{0, "ATR-White"},
 {1, "ATR-Lilac"},
 {2, "ATR-Brown"},
 {3, "ATR-Yellow"},
 {4, "ATR-Orange"},
 {5, "ATR-Red"},
 {6, "ATR-Grey"},
 {7, "ATR-Green"},
 {8, "ATR-Black"},
 {9, "ATR-Blue"},

{0, "MGA-White"},
 {1, "MGA-Golden"},
 {2, "MGA -Orange"},
 {3, "MGA-Green"},
 {4, "MGA-Yellow"},
 {5, "MGA-Lilac"},
 {6, "MGA-Blue"},
 {7, "MGA-Red"},

6



Press the  key in order to return to the previous menu.

11.4.2 EXECUTION WORKING CYCLE

It concerns the data management during the operating cycle. The indicator performs, according to the parameters configured, the acquisitions of the measures on the various sensors and the adjustment required.

1



Turn on the indicator by pressing .

2 The current working values appear



This visualization is available during the work.



11.5 WAY OF CALIBRATION AND SPRAYING BOOMS CONFIGURATION

These operations must be carried out when the treatment is not active (in manual mode and with all the switches in the OFF position).

- NOZZLE CALIBRATION:

It allows to define the characteristics of the type of nozzle used (liter/minute) in function of the pressure (bar). It is possible to choose from a set of pre-configured identifying marks (ISO standard) or to define new ones.

- TANK LEVEL CALIBRATION:



It sets the calibration points related to the level sensor of the tank.



- SPEED SENSOR CALIBRATION:

It calculates the rate constant based on a known distance to travel (100 m in EU and 300 feet in US).

1 Turn on the indicator by pressing



2 Keep pressing simultaneously  and  keys.

Slide the 3 voices of calibration through  and  keys.



3 **NOZZLE CALIBRATION (max 8).**

4 Press the  key to enter in the nozzle configuration.

Calibrations	
1. Nozzle calib. menu	
2. Tank level calib. menu	
3. Speed calibration menu	▼

5 Press again the  key to set up to 8 pairs of calibration values (Custom nozzle 1-8) related to the nozzle.

Nozzle calib. menu	
1. Custom nozzle 1	
2. Custom nozzle 2	
3. Custom nozzle 3	▼

6 Press again the  key to set the pressure and the flow rate for each nozzle using the  and  keys.

Custom nozzle 1		
Point 1 pressure	10.0	bar
Point 2 flow	6.50	l/min
Point 2 pressure	20.0	bar ▼

7  Press the **Reset Delete** key in order to return to the previous menu.

8 **TANK LEVEL CALIBRATION**

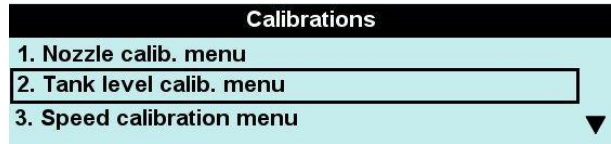

9  Press the **OK** key in order to enter in the tank configuration and to set the calibration points.

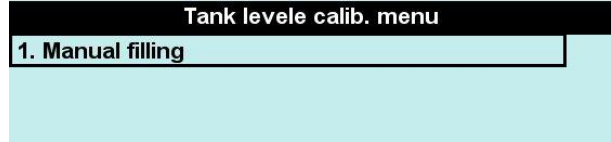

It is possible to define a minimum of 2 calibration points up to a maximum of 50.

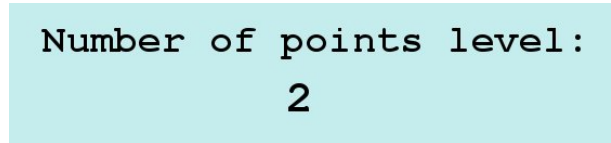

10  Press again the **OK** key in order to insert the Tank level in liters using the  and  keys.

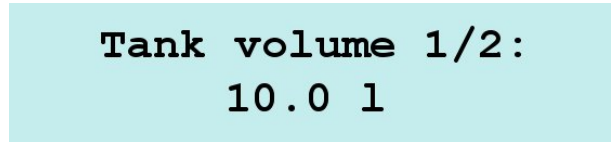

Pour clean water (in the previously fitted amount of it) into the tank and confirm it

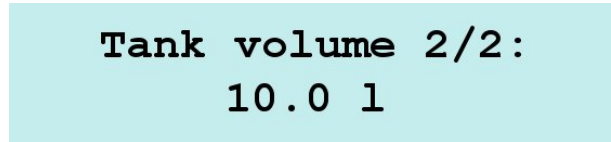

with the  key in order to move to the next value.

11 Definition of the second value. Completely repeat the operations of the step 9.

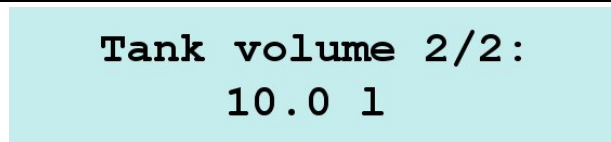

12 

Perform the steps 9 and 10 until the definition of all the calibration points you want to set (max 50).

13  Press the  key in order to finish the calibration.
If everything is successful, it appears the message "Done!".

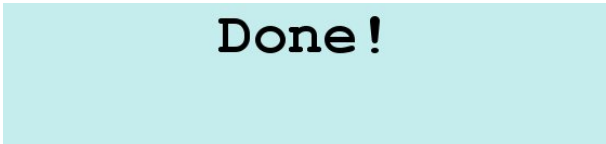

14 **SPEED SENSOR CALIBRATION**



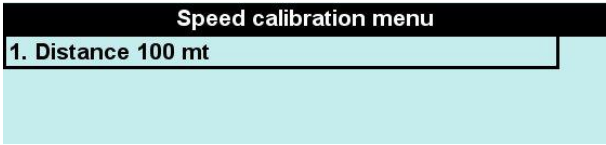

15  Press the  key to enter into the calibration.

16  Press the  key to select the distance on the basis of you would calibrate the speed sensor.

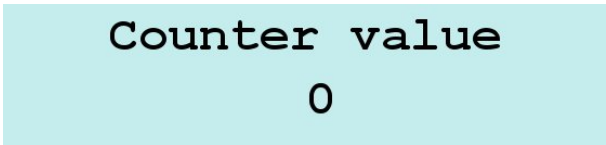

17 The message "Counter value" appears, it will increase as the tractor moves towards the finish line.



18  Press the  key when the tractor crossed the line (100 m in EU and 300 feet in US) in order to complete the calculation of the speed constant.

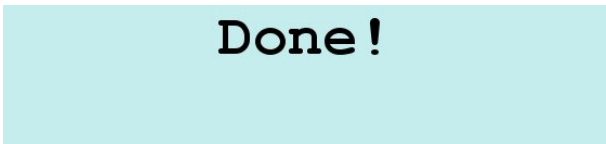

19  Press the  key in order to return to the previous menu.

11.6 VALUE OF SOFTWARE PARAMETERS

Limit values of the setting software parameters.

Parameter	Description	Min. / U.M.		Max. / U.M.		Note	
Language	Message language	ENG/ITA/SPA/DEU/ FRA/POR/POL/RUS/FIN					
Unit	Used metric system	l/ha, Km/h, bar o GPA, mph, psi*				Metrics/ US	
ID Vehicle	Vehicle on which the system is installed	1		5			
Number of valves	Number of valves	3		7		2,3,4,5, 6,7	
GPS connection	Type of GPS connection	None / GPS RX / AV G6 / TOP Xn / GEOSC1 / TUVR					
GPS minimum speed	Min. speed for GPS tracking	0.0 km/h	0.0 mph	5.0 km/h	3.1 mph	Metrics/ US	
GPS HDOP max. val.	Permissible max. value for GPS precision	0.0		10.0			
Variable rate	Enable the operating mode with the variable distribution value.	YES / NO					
Field Trace	Enable the data exchange with the Field Trace software	YES / NO					
Impulse Distance	Constant Flowmeter Value	1 imp/l	4 imp/USG	5000 imp/l	18927 imp/USG	Metrics/ US	
Minimum flow	Alarm threshold minimum flow	0 l/min	0 USGpm	10000 l/min	2642 USGpm	Metrics/ US	
Maximum flow	Alarm threshold maximum flow	0 l/min	0 USGpm	10000 l/min	2642 USGpm	Metrics/ US	
Corrective viscosity factor	Corrective viscosity factor	0.00		10.00			
Pulse distance	Speed sensor calibration	0.0 cm/imp	0.0 in/imp	6000.0 cm/imp	2362.2 in/imp	Round pulse Num.	
Speed source	Speed calculation	SIM/GPS/PROX					
Simulated speed value	Simulated speed value	0.0 km/h	0.0 mph	50.0 km/h	31.0 mph	Metrics/ US	
Threshold minimal speed	Value below which the spraying action is interrupted	0.0 Km/h	0.0 mph	50.0 Km/h	31.0 mph	Metrics/ US	
Threshold manual speed	Value below which the automatic management is not effectuated	0.0 Km/h	0.0 mph	50.0 Km/h	31.0 mph	Metrics/ US	
Speed response	Sensitive to the speed variation	1		5		1 fast 5 slow	

Pressure Calibration	Pressure sensor calibration	0 bar	0 PSI	200 bar	2901 PSI	Value of bottom scale
Pressure calculation	Pressure calculation	No		Yes		
Minimum pressure		0 bar	0 psi	200 bar	2901 psi	Metrics/US
Tank capacity	Value the tank can contain	0 l	0 USG	10000 l	2642 USG	Metrics/US
Minimum Tank level	Alarm threshold minimum level tank	0 l	0 USG	10000 l	2642 USG	Metrics/US
Specific weight	specific weight of tank liquid	0.00		10.00		
Tank level sensor	Level sensor	Yes		No		
Boom type	Specify the boom type installed	Symmetric/Asymmetric				
Nozzle number	Total number of nozzles.	0		1000		
Nozzle number section 1-7	Number of nuzzle per section	0		200		
Total boom width	Boom total width	0.00 mt	0.00 ft	100.00 mt	328.08 ft	Metrics/US
Width section 1-7	Partial width of the spray boom	0.00 mt	0.00 ft	25.00 mt	82.02 ft	Metrica/US
Maximum variation	Max % variation increase/decrease the flow rate	10 %		50 %		
Regulation response	Selection of the sensitivity of the automatic regulation	Auto / Low / Middle / High / Custom				
% tolerance of regulation	Value % of tolerance	0 %		20 %		
Presence of regulation sensors:	Sensor used for the autom. Reg. of the flow rate	Flowmeter / Pressure / Both				
Sections management	Sections management	Dependent		Free		
Regulation valve	Type regulation valve	Bypass		Throttling		
Section valve	Type section valve	On-Off		Calibrated		

General valve type		Bypass / Dump		
Input of activation of general valve	Enables the feature of external activation/deactivation of general valve in the corresponding operation mode	None / AutMan / Auto / Manual		
Level of general valve activation	Serves to determine the signal level corresponding to the status of active general valve	Low / High		
Set contrast	Contrast value	1	100	
Set data and time	Hour and data setting	Hour/Min/Day/Month/Year		
Check GPS		Check the functioning of the GPS		
Save configuration		Save the configurations on the USB key		
Read configuration		Read the configuration saved on the USB key		

***NB:** When the user chooses the US units, the indicator rounds off the values expressed in psi and in imp/USG to the nearest value of the related metrical unit of measurement.

Table 9 - General Parameters

Parameter	Description	Min. / U.M.		Max. / U.M.		Note
Working selection	Type of work	1		10		
Dosage setting	Current value of the amount of liquid	0 l/ha	0 GPA	10000 l/ha	1069 GPA	Metrics/US
ID nozzle	Identify the current nozzle	ISO, ATR, MGA or USER				
ISO	ISO nozzle	ISO-01		ISO-20		12 pre-configured
USER	USER nozzle	User 1		User 8		8 personalised

Table 10 - Working Parameters

11.7 WIDTH SECTION

For the proper functioning of GeoSystem 260 is not necessary the setting of the width of each single section but it is sufficient to indicate the total boom width and the width of only one side of single sections.

The length of the sections will be calculated based on the symmetry of the system.

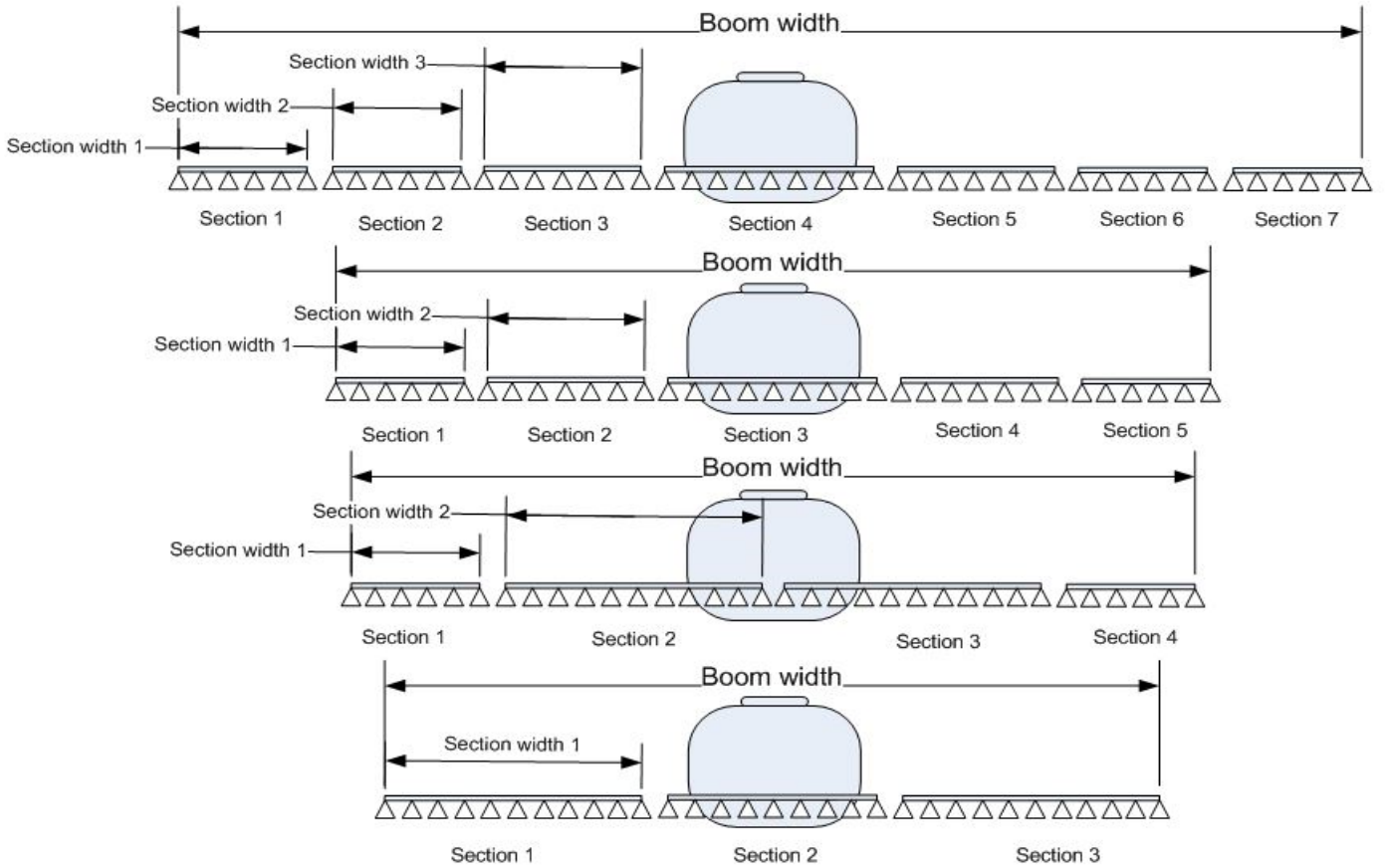

ENGLISH

Picture 23 – Coverage

12 HW TEST

It allows to effect the hardware test.



This test can be carried out only at starting.

1



Turn on the indicator by pressing [Power].

2 After viewing the software revision, when the message “Please Wait” appears, press simultaneously the



and



keys.

Please wait...

3 The message “HW test” appears.

HW Test

4 The value of Voltage appears and it is possible to slide the following values



and



through [Up] and [Down] keys.

**Voltage:
11.33 V**

5 The next data is the value of the analog input 1 of the Switch Box board corresponding to the pressure sensor.



**ExtAN1Input:
5.64 mA**

6 The next data is the value of the analog input 2 of the Switch Box board corresponding to the tank level sensor.



**ExtAN2Input:
5.64 mA**

7 The next data is the value of the external counter 1 corresponding to the

input of the flowmeter. 

**Ext counter1:
0.00 Hz**

8 The next data is the value of the external counter 2 corresponding to the input of the speed sensor.



**Ext counter2:
0.00 Hz**

9 The next data indicates the status related to the switches.

0 = OFF
1 = ON

By actuating the switches, the state will change from 0 to 1 and turning them off will return to 0.

**Switch status:
000000000000**

**Switch status:
111111001010**

10 This passage allows to check the correct functioning of the keys. The message "Press a key" will be displayed.

Press any key:

11 By keeping pressed a key, the name of the key appears temporarily on the display.



By pressing the Reset key, first the message "RESET KEY" appears; then the indicator goes on to the buzzer test.

**Press any key:
ENTER KEY**

12 Buzzer test.

During this passage an acoustic signal will be generated, confirming the correct functioning of the buzzer.

Buzzer ON!

13 Functioning test of the serial port 1 and serial port 2 of the indicator. In order to perform this test is necessary connect a probe on the GPS antenna connector.

You can request this probe to Geoline electronics.

**Test serial 1
Probe not connected!**

**Test serial 1
TX: RX:**

14 The next data corresponds to the temperature inside the box driver.

**Driver temperat:
0 C**

15 The next data corresponds to the SW revision of the valve driver board.

**Driver SW Vers:
0.0**

16 The next data indicates the USB software revision and the presence of the USB Key.

**USB SW Vers. 1.0
USB data key not present**

**USB SW Vers. 1.0
USB data key present**

17



Press the  key in order to return to the normal operation of the indicator.

18



To repeat the TEST HW it is necessary to switch off and on again the indicator.

13 USE OF GEOSYSTEM 260

13.1 DISPLAY

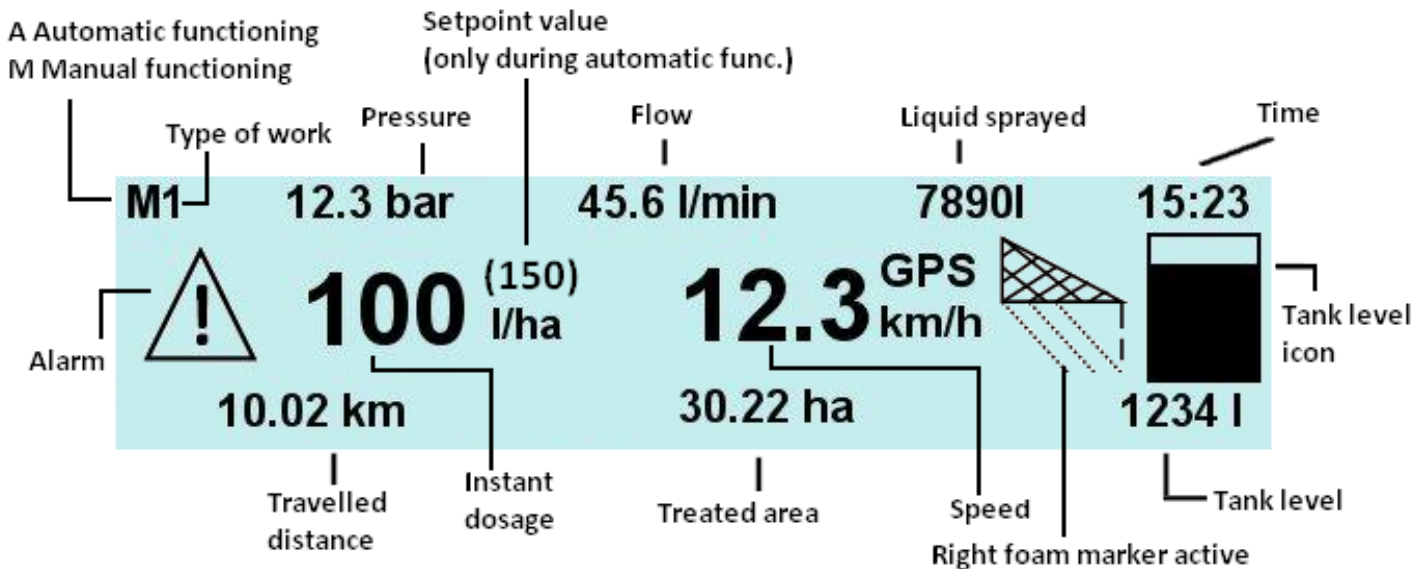

Figure 24 -Display

13.2 DEFINITION OF TREATMENT

The term “treatment” means the set of data recorded during an activity of Spraying or sprayer. The working parameters recorded by GeoSystem are stored in a tail. The tail can store a maximum of 20.

The data of each treatment can be visualized through the appropriate keys.

Every time you start a new treatment the data of the current treatment are inserted in the tail.

The treatment number 1 is the last treatment saved.

Treatment number 2 is the second last treatment saved and so on.

All treatments inserted in the queue slip of a position at the moment of every saving.

When the tail is full, the recording of a new treatment causes the cancellation of the treatment less recent (that in twentieth position).

After the treatment n° 20, appears the value “Treatment Total”, that refers to the historical data related to all the treatments.



This value cannot be deleted, not even through the memory RESET procedure (Start new treatment).

13.3 NEW TREATMENT

- 1 To start the recording of data on a new treatment, press the  key from the working values display.

- 2 Press the  key to select the "Start new treatment".

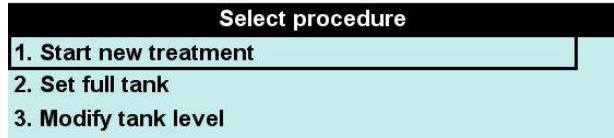

- 3 Press the  key to start a new treatment.

 Press KeyOK to start new treatment

- 4 By now, the counters are all reset.

Done!

13.4 TURNING ON GeoSystem 260

- 1 Turn on the indicator by pressing .

- 2 The first message "GEOline Electronic" will appear on the display.

GEO line electronic

- 3 Then the message "GEOline GeoSystem 260"

**GEOline
GeoSystem 260**

- 4 It shows the Firmware revision and the system name: Crop Sprayer.

**Rev.1.1.0
Crop Sprayer**



- 5 Then, it appears the message "Please Wait".

Please wait...

- 6  If the general valve is active (switch in ON position), when you are turn on the indicator, it will appear a message and then a sound of the buzzer to demand your attention.

 **WARNING!**
General valve is on

Disable the switch to interrupt the alarm.

7	The working values appears on the display and, eventually, additional markings such as:	
8	<ul style="list-style-type: none"> • the character “M”: it signals that the indicator is in manual mode. • The number “1” next to the letter M specifies the work type. 	
9	<ul style="list-style-type: none"> • the character “A”: it signals that the indicator is in automatic mode. • The pre-set value of distribution: it is shown between parenthesis next to the instant dosage value. 	
10	<ul style="list-style-type: none"> • The acronym GPS, displayed next to the speed value: it specifies that this value is acquired thank to GPS signal 	
11	<ul style="list-style-type: none"> • The acronym ERR, displayed next to the speed value: it specifies that there is an error during the acquiring of this value. 	
12	<ul style="list-style-type: none"> • The acronym SIM, displayed next to the speed value: it specifies that this value is simulated 	
13	<ul style="list-style-type: none"> • If there is no acronym displayed next to the speed value, this value is acquired through the proximity sensor. 	
14	<ul style="list-style-type: none"> • The symbol : this icon indicates the tank level. 	
15	<ul style="list-style-type: none"> • The symbol  on the left of the display: it indicates the presence of an alarm. The alarm identity will be display alternately in the last line of the display. 	

- 16 • **The symbol on the left of the tank icon:** it indicates that the foam marker is active.



It is possible to enable this option by

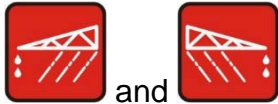

pressing and keys. Press again to turn it off.



Left foam marker



Right foam marker

- 17 At the starting, press simultaneously the keys to reset all the parameters of the indicator to the initial values.

Press ENTER to reset all memory

13.5 TURNING OFF GeoSystem 260

1



Press the key at least for 2 seconds in order to turn off the system.

- 2 Wait that the data of the last treatment will be saved.



During the turning off do not press any key and do not remove the power, until the control unit turns off.

Always use the appropriate button to turn off the computer, otherwise all the data relating to treatments and schedules will be lost.

13.6 AUTOMATIC FUNCTIONING

The automatic functioning is indicated by the letter A, situated on the left side of the display. The value between parenthesis is the dosage set by the user, GeoSystem 260 will drive the regulation valve looking for maintaining constant the dosage at the variation of the vehicle speed.

13.7 MANUAL FUNCTIONING

The manual functioning is indicated by the letter M, situated on the left side of the display. GeoSystem 260 will record the working data shown during the functioning.



If the user changes the dosage value through the proportional valve in the automatic functioning, it is possible to return to the initial value by pressing the  key in the working frame.

13.8 TANK REPLENISHMENT DURING A TREATMENT

1 If the field to treat requires an amount of liquid higher than the amount of the tank, it will be necessary to fill once or more times the tank.

2 At every replenishment you have to update the tank level (parameter: "Modify tank level ")

3 Press the  key from the working values display.

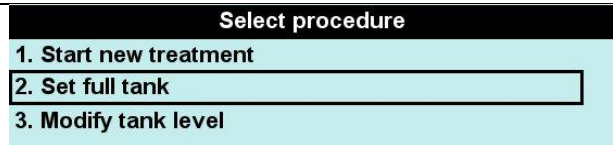

4 Press the  key to select "Set full tank".

5 Press the  key to set full tank.

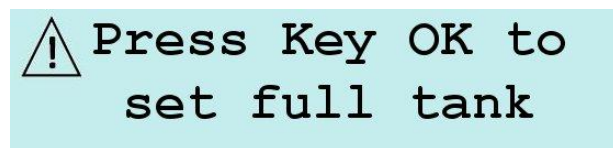

6 Press the  key in order to set manually the quantity of liquid loaded on the tank.

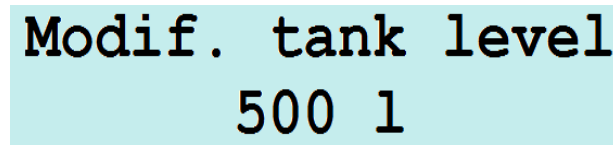

7 The parameter is automatically updated with the maximum tank capacity value. (parameter "Tank capacity")



8 To modify the value, enter in modifying phase pressing the OK key and using

the  and  keys to increase or decrease the value.

Select procedure	
1.	Start new treatment
2.	Set full tank
3.	Modify tank level

9 Press the  key to confirm the set value.

Change tank level
1058 1

13.9 HYSTORICAL TREATMENTS

It allows to check the counters related to working.

13.9.1 READING TREATMENTS

1 Turn on the indicator by pressing



2 Press and hold the  key for 3 seconds to access the statistics of the operating mode.

3 Shows the name “treatment” and a date or number: the date indicates that the treatment was saved and the related data are available. On the other side, the number indicates that there are no data saved in that position. The user can enter only in the first one.

Historical treatments	
1. Treatment	16-06-14
2. Treatment	2
3. Treatment	3

4 Scroll the last 20 treatments through



The treatment N° 1 relates to the treatment more recently while the treatment N° 20 is the oldest one.

5 After the treatment n° 20, appears the total value that refers to the historical data related to the treatments.



Historical treatments	
19. Treatment	19
20. Treatment	20
21. Treatment Total	



It is possible to export only the single performed treatments, not the total.

6

Press the  key to verify the individual counts of each treatment.

Through  and  keys, display the values relating to the treatments carried out, such as:

- Date
- Time
- Type of work

Treatment 1	
Date	16-06-2014
Time	16:28
Work ID	1 ▼

- The value of the treated area (ha)
- The value of the total liquid sprayed (l)
- The traveled distance (Km)

Treatment 1		
Surface	18.50	ha ▲
Total liquid	45	l
Distance	6.7	km ▼

- The duration of the treatment performed (hh:mm)
- Average speed (km/h)
- Maximum speed (km/h)

Treatment 1	
Treatment duration	08:46 ▲
Average speed	3.0 km/h
Maximum speed	6.0 km/h ▼

- Longitude
- Latitude
- The destination of the saving data

Treatment 1	
Longitude	0.000000 ▲
Latitude	0.000000
Save treatment to	USB



13.10 RECALL DATA OF TREATMENTS

1

Press for 3 seconds the  key, in order to access to the menu that allows to visualize the tail of last 20 treatments performed.

Historical treatments	
1. Treatment	16-06-14
2. Treatment	2
3. Treatment	3 ▼

2

Using the  and  keys in order to scroll the list of treatments. Press the  key in order to access to the content.

14 ALARMS

14.1 WARNING AND ALARMS

There are some warnings and alarms to highlight unusual states that show anomaly functioning.

At the activation of an alarm, you will hear the buzzer.

Press  key to disable it.

The active alarm state is highlighted by the

sign  on the left of the display; the alarm identity will be display alternately in the last line of the display.



14.2 LIST OF POSSIBLE ALARMS

1. Valve box alarm:

There is no communication between the indicator and the Valve Box.



2. Flow regulation alarm:

the indicator has to reach a flow set point value(l/ha), if it can not reach this value, the indicator gives a signal after a minute.



3. Tank empty alarm:

it gives this alarm when it reaches the minimum flow of liquid in the tank set with the parameter **Alarm threshold minimum tank level**



4. Minimum flow alarm:

The amount of sprayed liquid (l/min) is lower than the parameter value **Alarm threshold minimum flow**



5. Maximum flow alarm:

the amount of sprayed liquid (l/min) is higher than the parameter value **Alarm threshold maximum flow**



6. Low battery level alarm:

the battery level is lower than 9.0 Volts



7. Low pressure alarm:

The alarm is generated after 15 seconds with a pressure less than the parameter **Minimum pressure**



8. Low GPS signal alarm:

The alarm is generated when the maximum admissible GPS accuracy value (HDOP) is higher than the value set with the “*GPS HDOP max. val.*” parameter.

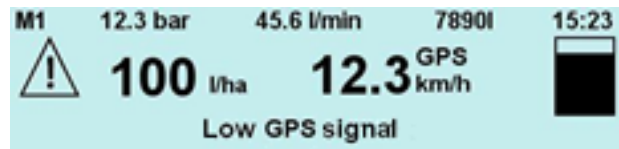
**9. Active boom control alarm:**

The alarm is generated when the Geosystem 260 is connected to a GPS navigation system and, during an active



treatment session, the key is pushed to temporarily disable the control of the boom sections from the navigator. The control can be reset pushing the same key.

**10. Voltage drop Driver Box alarm (Driver overload):**

The alarm is generated when the Driver Box checks for high absorption when the proportional valve is activated.

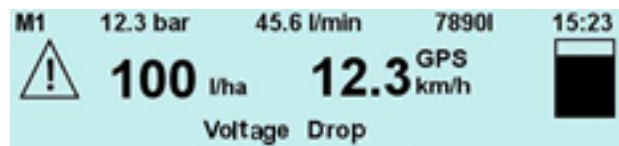
**11. General valve OFF:**

The alarm is generated when the general valve is deactivate by the external signal if the “*Input general valve activation*” is set different from “*None*” and the input signal corresponds to the set one.

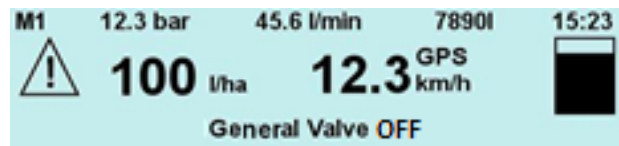

15 TROUBLESHOOTING

DISPLAY	CAUSE	SOLUTION
The display does not turn on	There is not power.	Check the connections on the power cable.
	The indicator is turned off.	Press the turning on button.
The valves can not be controlled	The valves are not connected.	Connect the connectors
A valve does not open	The valve has not power.	Check the electric connection and the functioning of the valve
The counting of the travelled distance shown on the computer is different from the real one.	Wrong programming	Check the connection with the speed sensor.
	The reset of the treatment has not been effectuated	Reset the treatment
The counting of the travelled surface shown on the computer is different from the real one.	Wrong programming	Check the bar width programming
	The reset of the treatment has not been effectuated	Reset the treatment
The instant pressure is not shown.	The indicator has not signal from the pressure sensor	Check the connections with the pressure sensor
	Wrong installation of the pressure sensor	Check the bottom scale programming for the pressure sensor
The instant pressure visualized is inaccurate.	Wrong programming	Check the bottom scale programming for the pressure sensor
	The pressure sensor is not calibrated	Do the calibration
	Wrong installation of the pressure sensor	Check the connections with the pressure sensor
The tank level visualized is inaccurate.	The level sensor is not calibrated.	Do the calibration. Repeat the level sensor calibration.
	Wrong installation of the level sensor.	Check the connection with the level sensor
The general valve does not activate.	External input for the activation of general valve set in a different functioning mode than the current one.	Check that the "Input for general valve activation" parameter is configured as "None" or that it corresponds to the current activation mode " <i>Manual / Auto / AutoMan</i> ".
	External input for the activation of general valve set for incorrect current level.	<i>Alto o Basso</i> . Check that the " <i>General valve activation level</i> " is configured with the activation mode corresponding to the level of input signal " <i>High</i> " or " <i>Low</i> ".

Table 11 - Troubleshooting

16 OTHER CONFIGURATIONS

16.1 EXEMPLE OF GeoSystem 260 5W CS INSTALLATION ON SPRAYER SYSTEM WITH 4 SECTIONS

1 Make sure the system is exactly connected as on picture 8 at page 10.

2 In this step it is not important the sensor connection but the valve cable connection and the GeoSystem 260 driver box output connection.

3 Make sure all the switches are in OFF position so turn on the indicator by



pressing the key.

4 The first message "GEOline Electronic" will appear on the display.



5 Then the message "GEOline GeoSystem 260"

**GEOline
GeoSystem 260**

6 It shows the Firmware revision and the system name: Crop Sprayer.

**Rev.1.1.0
Crop Sprayer**

7 Then, it appears the message "Please Wait".

Please wait...

8 The working values appear.



9 Press simultaneously the  and



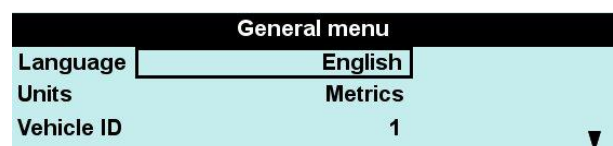

keys to enter into the general configuration and then in the general

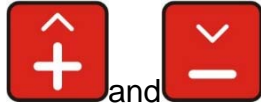

menu.

- 10 Scroll up and down the entries of the



menu using the  and  keys to arrive at the parameter “Valves number”.

General menu		
Valves number	5	▲
GPS connection	GPS	
GPS Minimum speed	0.5	km/h ▼

- 11



Press the  key to change the valves number.



Go to the next step to verify the operation of the valves otherwise skip to step number 15.

- 12 Set the number of valves and press



the  key to confirm.

General menu		
Valves number	5	▲
GPS connection	GPS	
GPS Minimum speed	0.5	km/h ▼

- 13



Press the  key to exit and to launch again the indicator.

- 14 When the indicator is on working mode, activate the switch number 1 (in ON position) and check the valve number 1 is working.
Then, disable the Switch 1 (in OFF position) and try with the Switch number 2 and so on for the selected number of valves. Repeat the test for all the valves.



Picture 25 - Use of 5 sections

- 15 If all the connected valves are working, enter again in configuration menu and set the valve number at 4.

General menu		
Valves number	4	▲
GPS connection	GPS	
GPS Minimum speed	0.5	km/h ▼

- 16 At this point the indicator is working with only 4 connectors as indicated on picture:

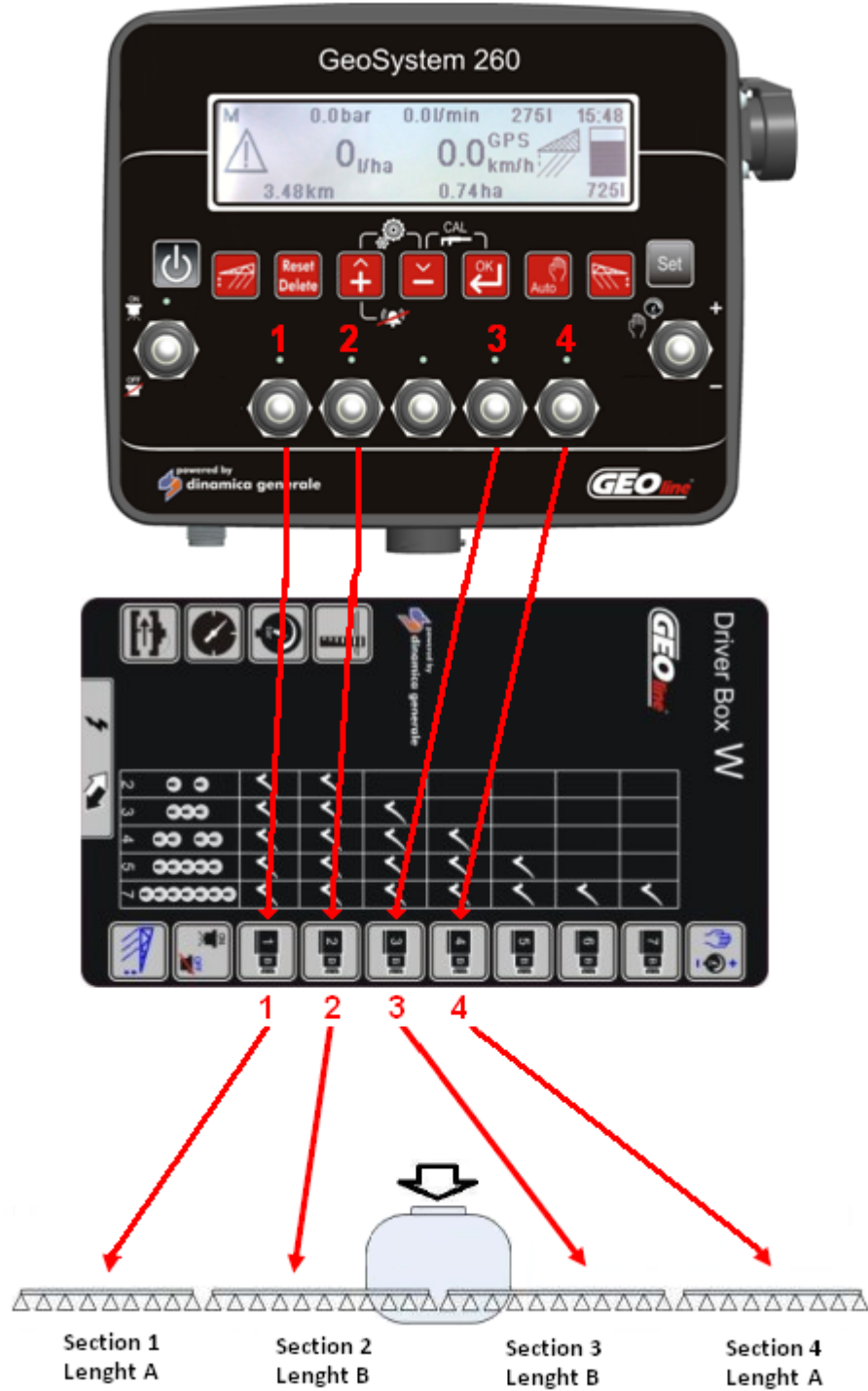

Picture 26 – Use of 4 sections

**17 DICHIARAZIONE DI CONFORMITA' UE EU DECLARATION OF CONFORMITY EU
KONFORMITÄTSERKLÄRUNG DÉCLARATION UE DE CONFORMITÉ
DECLARACION UE DE CONFORMIDAD EU ДЕКЛАРАЦИЯ О СООТВЕТСТВИИ**

Nr 16/16

- IT** Il sottoscritto, designato a legale rappresentante della Dinamica Generale s.p.a. , via Mondadori 15, Poggio Rusco (MN) - Italy, dichiara che i prodotti sottoelencati:
- EN** The undersigned, an authorised officer of Dinamica Generale s.p.a. , via Mondadori 15, Poggio Rusco (MN) - Italy, hereby declares that the products listed hereunder:
- D** Der Unterzeichner, rechtlicher Vertreter der Dinamica Generale s.p.a. , via Mondadori 15, Poggio Rusco (MN) – Italy, erklärt, daß die nachstehend beschriebenen Produkte:
- FR** Je soussigné, représentant légal désigné de Dinamica Generale s.p.a. , via Mondadori 15, Poggio Rusco (MN) - Italy, déclare que les produits énumérés ci-après:
- ES** El suscrito, nombrado representante legal de la Dinamica Generale s.p.a. , via Mondadori 15, Poggio Rusco (MN) - Italy, declara que los productos indicatos a continuación:
- RU** Нижеподписавшийся, являющийся законным представителем компании Dinamica Generale s.p.a., расположенной по адресу via Mondadori 15, Poggio Rusco (MN) – Italy, заявляет, что продукция ниже

ENGLISH

GeoSystem 260 CS

- IT** Sono conformi a quanto prescritto dalle seguenti direttive:
- EN** Are in compliance with the following directives:
- D** Mit den Vorschriften konform sind, die in den folgenden Richtlinien:
- FR** Sont conformes aux prescriptions des directives suivantes:
- ES** Respetan las prescripciones contenidas en las siguientes directivas:
- RU** Соответствует требованиям следующих директив:

2014/30/UE

- IT** E dalle seguenti norme:
- EN** And with the following standards:
- D** Und Normen stehen:
- FR** Et aux normes ci-apres:
- ES** Y en las siguientes normas:
- RU** И следующих стандартов:

EN ISO 14982 Agricultural and forestry machinery -- Electromagnetic compatibility -- Test methods and acceptance criteria

- IT** E, in applicazione a quanto previsto dalle direttive citate, sono stati dotati di marcatura CE ed é stato predisposto un adeguato fascicolo tecnico presso la ns. sede.
- EN** And, pursuant of the above-mentioned directives, the CE mark has been applied. Furthermore, adequate technical file has been prepared and is available from our offices.
- D** Und daß sie in Übereinstimmung mit den Vorschriften der obengenannten Richtlinien mit dem CE-Zeichen versehen sind und daß dafür ein angemessenes technisches Heft erstellt wurde, das bei uns in der Firma zur Verfügung steht.
- FR** En application des directives citées, ils portent la marque CE et un dossier technique est déposé auprès de notre siège.
- ES** Y, conforme con lo previsto en las citadas directivas, han recibido la marca CE. Existe asimismo un específico prospecto técnico relativo disponible en nuestra sede.
- RU** И, в исполнении данных директив, был нанесен знак CE и соответствующее техническое досье было заведено в нашем офисе.

Poggio Rusco, 19/04/2016

Andrea GHIRALDI



18 GUARANTEE

The supplier guarantees, for 24 months from the delivery date, the good quality of materials used, the excellent construction and the steady functioning of the instrument they have manufactured and that bears the trademark or the production serial number. During the guarantee period the supplier undertakes to repair or replace, free supplier's head office, faulty parts due to poor materials or faulty construction, provided that such parts are delivered free port supplier's head office.

Shortcomings and defects due to incorrect use of instruments, inadequate maintenance, changes carried out without the supplier's approval, normal wear are not included in this guarantee.

Liability and compensations by the supplier due to direct or indirect damages to persons, objects or production, even as a consequence of faulty functioning of the supplied instruments or of material or construction defects, are not included in this guarantee.

NOTES:

GEOLine electronic reserve itself the right to modify the contents of this manual caused by hardware and software implementations in order to a constant improvement of the product and so a better service to the user.

19 ISO TABLE

NOZZLE [l/min]					
bar	4	8	12	16	20
ISO-01	0.45	0.64	0.78	0.91	1.01
ISO-015	0.68	0.96	1.18	1.36	1.52
ISO-02	0.92	1.30	1.60	1.85	2.07
ISO-025	1.15	1.63	2.00	2.31	2.89
ISO-03	1.37	1.94	2.38	2.75	3.07
ISO-04	1.82	2.58	3.16	3.65	4.08
ISO-05	2.28	3.22	3.94	4.55	5.09
ISO-06	2.73	3.86	4.72	5.45	6.09
ISO-08	3.70	5.23	6.40	7.39	8.26
ISO-10	4.62	6.53	8.00	9.24	10.33
ISO-15	6.84	9.79	12.0	13.86	15.49
ISO-20	9.24	13.06	16.0	18.48	20.66

Table 12 - ISO table

20 ATR TABLE

NOZZLE TYPE [l/min]					
bar	3	9	15	20	25
ATR-White	0.22	0.38	0.45	0.52	0.58
ATR-Lilac	0.28	0.48	0.61	0.70	0.77
ATR-Brown	0.38	0.64	0.81	0.93	1.04
ATR-Yellow	0.57	0.97	1.25	1.44	1.61
ATR-Orange	0.77	1.32	1.69	1.94	2.16
ATR-Red	1.08	1.83	2.33	2.67	2.97
ATR-Grey	1.18	1.98	2.51	2.88	3.20
ATR-Green	1.40	2.35	2.99	3.42	3.80
ATR-Black	1.57	2.64	3.36	3.85	4.28
ATR-Blue	1.92	3.24	4.12	4.72	5.25

Table 13 - ATR table

21 MGA TABLE

NOZZLE TYPE [l/min]					
bar	4.83	6.89	10.34	13.79	20.68
MGA-White	0.25	0.29	0.34	0.40	0.50
MGA-Golden	0.33	0.39	0.46	0.56	0.63
MGA-Orange	0.50	0.59	0.68	0.82	0.88
MGA-Green	0.75	0.90	1.05	1.25	1.53
MGA-Yellow	1.00	1.20	1.42	1.65	2.03
MGA-Lilac	1.25	1.50	1.81	2.07	2.51
MGA-Blue	1.50	1.80	2.20	2.50	3.00
MGA-Red	2.10	2.55	3.10	3.50	4.30

Table 14 - MGA table

“QUICK REFERENCE” GeoSystem 260 CS

TREATMENT PREPARATION

1

To start the data recording of a new treatment, press the  key and select the parameter “Start new treatment”.

2 The system stores the treatment data in a tail of 20 elements.

3 N.B: if the level sensor is not present, the pressure of the key will reset all the working data, except for the tank level which is reload to a pre-set value in configuration phase.

Select procedure	
1.	Start new treatment
2.	Set full tank
3.	Modify tank level

USE

1 Automatic functioning of the system: GeoSystem 260 shows and records the speed, flow, travelled distance, treated area, amount of sprayed liquid values, tank level, coverage section and it operates in a active way on the propositional valve. Moreover, it constantly maintains the dosage value at the variation of the vehicle speed and of the number of the active section valves.

M1	12.3 bar	45.6 l/min	7890l	15:23
	100 l/ha	12.3 GPS km/h		
	10.02 km	30.22 ha		1234 l

2

Press the  key to activate the automatic functioning until letter A appears on display and then, activate the wanted section valves.

3

Press the  key to select the working values, if necessary.

4 Open the general valve and power up the tractor.

5

Place the switch  upwards to increase the amount of sprayed liquid, downwards to decrease it.

TANK REPLENISHMENT

1 If the treatment requires more chemical substance than how the vehicle tank can contains, the operator has the possibility to supply the tank with liquid and to eventually modify the insert quantity.

2 If the level sensor is not present, you have to manually set the tank level data.



In this case select the “Modify tank level” data and press the  key to modify the data which is reloaded at the pre-set value in configuration phase.

TREATMENT VISUALIZATION

1 Press for 3 seconds the  key to enter into the menu that allows to visualize the tail of the last 20 treatments.

Historical treatments	
1.	Treatment 16-06-14
2.	Treatment 2
3.	Treatment 3

2

Using the  and  key, it is possible to scroll up and down the treatment list. Press

 to enter into the one of them.

DISPLAY VISUALIZATION

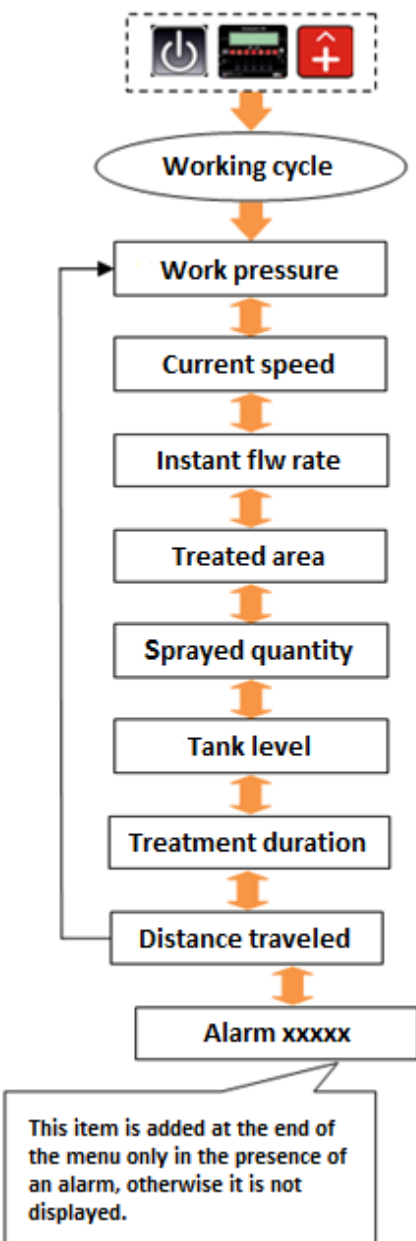
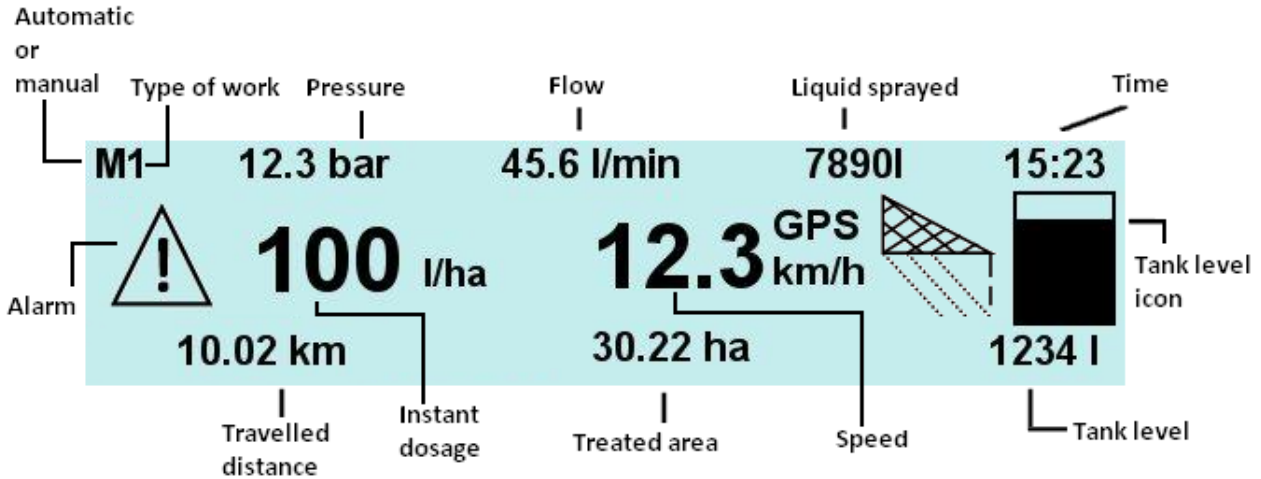

ALARMS

At the activation of one alarm you will hear a sound from the buzzer.

Press to disable it.

The active alarm state is highlighted by the sign on the left of the display.

1. Valve box alarm

M1	12.3 bar	45.6 l/min	7890l	15:23
	100 l/ha	12.3 GPS km/h		
Valve Driver Box				

2. Flow regulation alarm

M1	12.3 bar	45.6 l/min	7890l	15:23
	100 l/ha	12.3 GPS km/h		
Flow regulation				

3. Tank empty alarm

M1	12.3 bar	45.6 l/min	7890l	15:23
	100 l/ha	12.3 GPS km/h		
Tank empty				

4. Minimum flow alarm

M1	12.3 bar	45.6 l/min	7890l	15:23
	100 l/ha	12.3 GPS km/h		
Minimum flow				

5. Maximum flow alarm





M1	12.3 bar	45.6 l/min	7890l	15:23
	100 l/ha	12.3 GPS km/h		
Maximum flow				

6. Low battery alarm

M1	12.3 bar	45.6 l/min	7890l	15:23
	100 l/ha	12.3 GPS km/h		
LOW BATTERY!				

7. Low pressure alarm

M1	12.3 bar	45.6 l/min	7890l	15:23
	100 l/ha	12.3 GPS km/h		
Low pressure				

8. Low GPS signal alarm	 M1 12.3 bar 45.6 l/min 7890l 15:23 100 l/ha 12.3 GPS km/h Low GPS signal
9. Active boom control alarm	 M1 12.3 bar 45.6 l/min 7890l 15:23 100 l/ha 12.3 GPS km/h Boom control activ.
10. Voltage drop Driver Box alarm	 M1 12.3 bar 45.6 l/min 7890l 15:23 100 l/ha 12.3 GPS km/h Voltage Drop
11. General valve OFF	 M1 12.3 bar 45.6 l/min 7890l 15:23 100 l/ha 12.3 GPS km/h General Valve OFF



CONTACTS

INFO & SALES

sales_dept@geoline.it

SUPPORT

support@geolineelectronic.com

QUALITY & CERTIFICATIONS

For **GEOLINE Electronic S.r.l.**, sustainability means integrating long term economic, environmental and social dimensions into the way we operate our business according to the:



ISO 9001:2008



ISO 14001:2004



GEOLINE Electronic S.r.l. uses PEFC paper for printing manuals and catalogues.

SOLD & SUPPORTED BY



FARMSCAN PTY LTD
ABN 76 632 674 545
Unit 4, 27 Mordaunt Circuit, Canning Vale WA 6155
Sales: (08) 6102 3200 Support: 0480 018 282
www.farmscan.com.au