

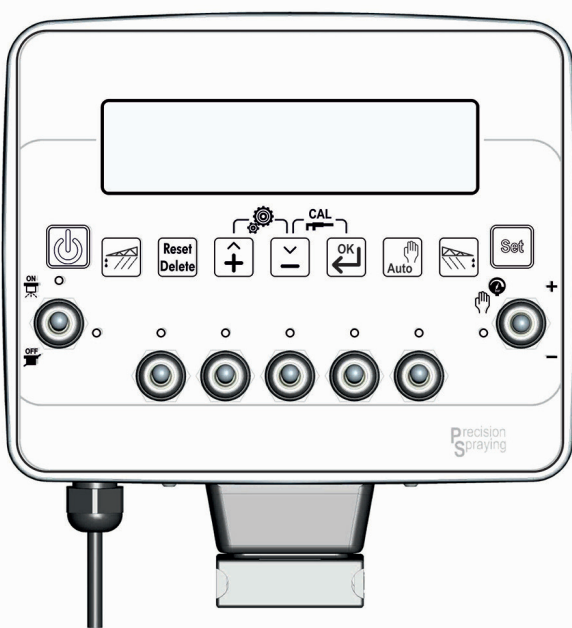

OPERATOR'S MANUAL



GeoSystem 240 5 Section Crop Sprayer

AM-240 | V1 0220



ENG All rights reserved. The reproduction of this manual, either totally or partially, in any form whatsoever, whether on paper or through computer processes, is strictly prohibited.
GEOLine Electronic S.r.l. and the team involved in the preparation of this manual will not be held responsible for any problem arisen as a result of improper use of this manual, as they guarantee that the information contained in it has been subjected to careful inspection. The products are continuously checked and improved. For this reason GEOLine Electronic S.r.l. reserves the right to modify the information contained in this manual without prior notice.

GEOLine Electronic S.r.l. Team

1 INDEX

1	INDEX	1
2	INTRODUCTION	2
3	LEGEND	3
4	INTENDED USE	3
5	WARNING	4
6	PACKAGE CONTENT	5
7	DIMENSIONS	5
8	ACCESSORIES	6
9	TECHNICAL DATA	6
10	INSTALLATION OF COMPONENTS	7
	10.1 CONFIGURATIONS	7
	10.2 CONNECTIONS SCHEME	9
	10.3 COMPUTER INSTALLATION	11
	10.4 SPEED SENSOR INSTALLATION	11
	10.5 FOAM MARKER CONNECTION CROP SPRAYER VERSION (CS)	12
	10.6 FLOWMETER INSTALLATION	12
	10.7 CHECK HARDWARE INSTALLATION	13
11	INTERFACE DESCRIPTION OF CROP SPRAYER (CS) INDICATOR	13
	11.1 TABLE LIST OF BUTTONS AND SWITCHES AND THEIR FUNCTIONS	13
	11.2 MENU STRUCTURE	16
	11.3 CONFIGURATION GENERAL PARAMETERS	17
	11.4 CONFIGURATION WORKING PARAMETERS	23
12	INTERFACE DESCRIPTION OF ORCHARD SPRAYER (OS) INDICATOR	26
	12.1 TABLE LIST OF BUTTONS AND SWITCHES AND THEIR FUNCTIONS	26
	12.2 MENU STRUCTURE	28
	12.3 CONFIGURATION GENERAL PARAMETERS	29
	12.4 CONFIGURATION WORKING PARAMETERS	34
13	UTILIZZO DEL SISTEMA	37
	13.1 EXECUTION WORKING CYCLE	37
	13.2 WAY OF CALIBRATION	40
	13.3 VALUE OF SOFTWARE PARAMETER	43
	13.4 SECTIONS' WIDTH CROP SPRAYER (CS)	45
	13.5 BOOM SECTION ORCHARD SPRAYER (OS)	46
	12.1 MANAGEMENT OF TREATMENTS WITH 4 SECTION (OS)	47
14	HW TEST	49
15	USE OF GEOSYSTEM 240	51
	15.1 DISPLAY CROP SPRAYER (CS) 2 VALUES	51
	15.2 DISPLAY CROP SPRAYER (CS) 4 VALUES	51
	15.3 DISPLAY ORCHARD SPRAYER (OS)	52
	15.4 DEFINITION OF TREATMENT	52
	15.5 NEW TREATMENT	53
	15.6 TURNING ON GeoSystem 240	53
	15.7 TURNING OFF GeoSystem 240	56
	15.8 PREPARATION	56
	15.9 AUTOMATIC FUNCTIONING	57
	15.10 MANUAL FUNCTIONING	57
	15.11 TANK REPLENISHMENT DURING A TREATMENT	57
	15.12 TOTALIZERS	58
	15.13 RECALL DATA OF TREATMENTS	59

16	ALARMS	60
	16.1 WARNING AND ALARMS	60
	16.2 LIST OF POSSIBLE ALARMS	60
17	TROUBLESHOOTING	61
18	OTHER CONFIGURATIONS CROP SPRAYER (CS)	62
	18.1 EXAMPLE OF GeoSystem 240 5W CS INSTALLATION ON SPRAYED SYSTEM WITH 4 SECTIONS	62
	18.2 EXAMPLE OF GeoSystem 240 5W CS INSTALLATION ON SPRAYER SYSTEM WITH 3 SECTIONS	65
19	OTHER CONFIGURATIONS ORCHARD SPRAYER (OS)	68
	19.1 GeoSystem 240 4OS INSTALLATION ON SPRAYER SYSTEM WITH 2 SECTIONS	68
20	EU DECLARATION OF CONFORMITY	71
21	GUARANTEE	72
22	ISO TABLE (CS/OS)	73
23	ATR TABLE (OS)	74
24	MGA TABLE (OS)	74
	"QUICK REFERENCE" GEOSYSTEM 240	75
	DISPLAY CROP SPRAYER (CS) 2 / 4 VALUES	76
	DISPLAY ORCHARD SPRAYER (OS)	76
	ALARMS	76

3 LEGEND

This user's manual uses some conventional signs, in order to lead the user during the reading of important instructions and advices; these concern especially the setting of the parameters of the system and thus its correct working. Please pay attention to the following icons:



It indicates further explaining and information.



It highly recommends to pay attention.



It indicates an operation that can be repeated many times, cyclically.



It indicates the norms to respect.

4 INTENDED USE

Management system of distribution designed to work on agricultural machinery for spraying and crop spraying applications. The accurate control of the operating parameters of the system sprayer or orchard increases the effectiveness and efficiency of the treatments, reducing the wastage of chemicals.

5 WARNING



The power supply must be connected directly to the battery or to a regulated feeder.

The power supply must be protected with a 10A fuse.

If it is not the case, GEOline electronic is not responsible for damages to the micro computer.



Disconnect the power supply cable from the micro computer when the battery is undergoing recharge.

If it is not the case, GEOline electronic is not responsible for damages to the micro computer.



Disconnect all lines from the local plant before undertaking welding on the vehicle.

If it is not the case, GEOline electronic is not responsible for damages to the micro computer.



For a correct functioning, please make sure that the battery has always a higher voltage than 10,5 Volt.



This marking on the product or on its packaging illustrates that this product may not be disposed of with normal household waste.

You are responsible for disposal of this equipment through a designated waste electrical and electronic equipment collection. To determine the locations for dropping off such waste electrical and electronic, contact your government office, the waste disposal organization that serves your household or the company at which you purchased the product.



Before cleaning the agricultural vehicle with high pressure water jets, protect the equipment from any possible water entrance. In addition, take great care not to subject the devices, cables or any options to direct jets of water.



If the equipment needs to be cleaned, use a soft, damp, lint-free cloth. Do not use sprays, solvents, abrasives, or sharp or pointed objects that could damage the indicator.

6 PACKAGE CONTENT

ENGLISH

Kit GeoSystem 240	
Description	Qty
Indicator GeoSystem 240	1
Power cable L=2 m	1
Extension cable L=5 m (if available)	1
Valves and sensors connection cable	1
Speed sensor with cable L=5 m	1
Dove Tail Bracket	1

Table 1- Package

7 DIMENSIONS

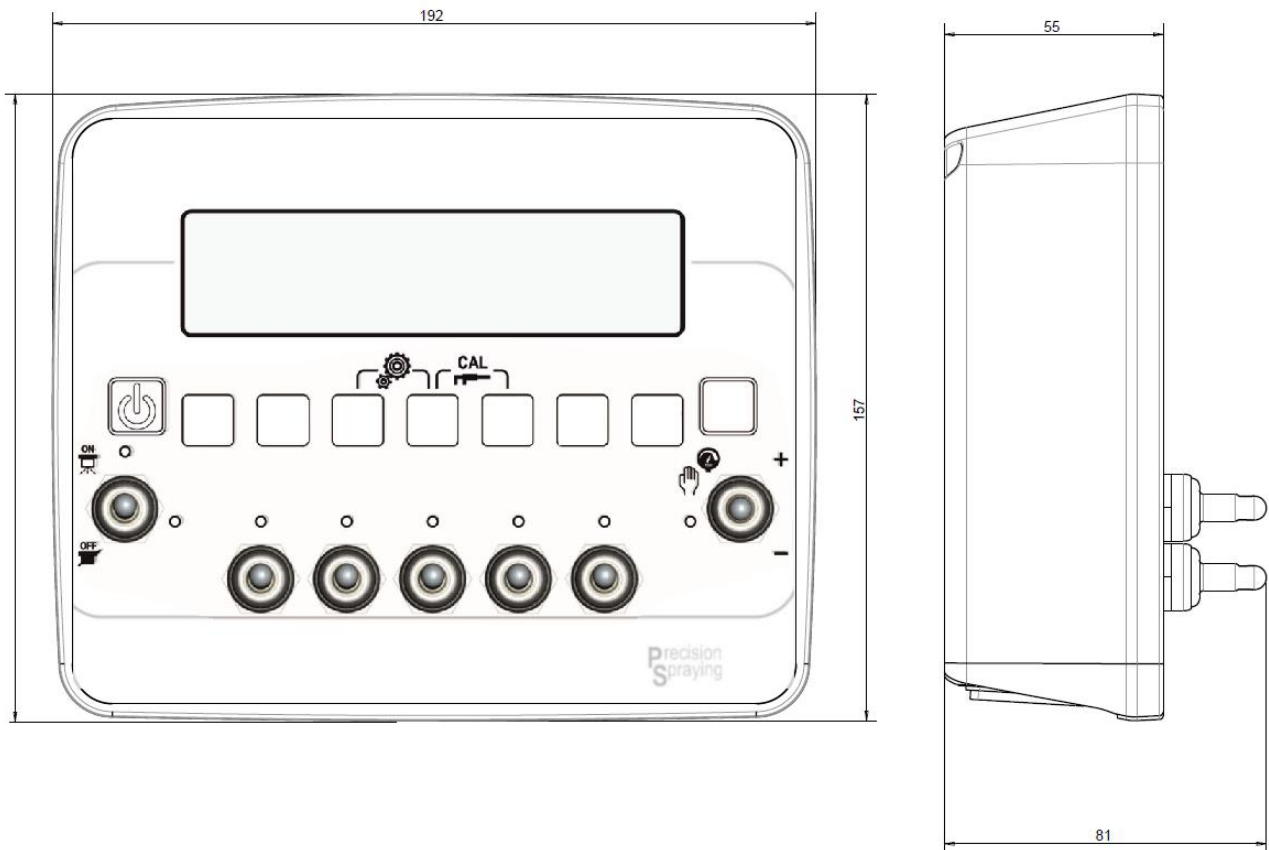

Picture 1 – Dimensions of indicator

8 ACCESSORIES

GeoSystem 240 may be equipped by these accessories:

ACCESSORY	DESCRIPTION
Magnetic Flowmeter	A sensor to noting the flow and to calculate the litres
Paddle Flowmeter	A sensor to noting the flow and to calculate the litres
Pressure Sensor	A sensor to measuring the pressure
Level Sensor	A sensor to measuring the liquid level in the tank
Sucker hangers with mini VESA connection	Hanger to fix in a glass surface

Table 2 - Accessories

9 TECHNICAL DATA

Indicator Dimensions(mm):	192 x 157 x 55 (without fixing support)
Indicator weight (gr):	~ 1000
Indicator Case:	PA66+GF 30 % native color RAL 9005
Indicator Protection:	IP 64
Operating temperature:	-20 / +65 °C
Storage temperature:	-20 / +65 °C
Power supply:	9,5 – 14 Vd.c. (alarm "LOW BATTERY" < 9,5 Vdc) Maximum total absorption: OS Version: 10A with maximum 2A for each output CS Version: 8A with maximum 1.5A for each output
Display:	Alphanumeric display 16 column x 2 rows area dimensions 123 x 30.4 mm with backlight
Display view:	> 2 mt
Types of connection cables:	Cables to connect the section valves, the general valve and the proportional valve
	Cables to connect sensor of pressure, tank level, flow and speed (if they are present)
	No.1 Cable to connect the foam marker (Crop Sprayer)
Power cable:	2 m

Table 3 - Technical Data

10 INSTALLATION OF COMPONENTS

10.1 CONFIGURATIONS

10.1.1 Indicator GeoSystem 240 Crop Sprayer (CS)

On the front, there are a series of switches that manage the section valves of the sprayer, the general control valve and the switch to increase / decrease the flow rate. It is envisaged also the manual and automatic regulation of the flow.

The operator sets the value of the liquid sprayed (liters per hectare) and the indicator regulates the volumetric valve depending on the speed of travel and on the active sections.

The operator can act on the regulation switch if he wants to increase or decrease the amount of liquid sprayed.



Figura 3 - Indicator Crop Sprayer (CS)

1. ON / OFF key.
2. Series of switches in 2 positions (ON-OFF) to control the general valve and section valves (5 valves). 1 switch with 3 positions (ON-OFF-ON) with spring return in the OFF command for volumetric valve
3. Function and setting key
4. Alphanumeric display 2 rows for 16 characters with backlight.

The system is supplied with pre-drilled mounting bracket. It is provided for a MED fastening system (optional) with dedicated accessories.
 The system is able to shore up a maximum load of 2.5 Kg.

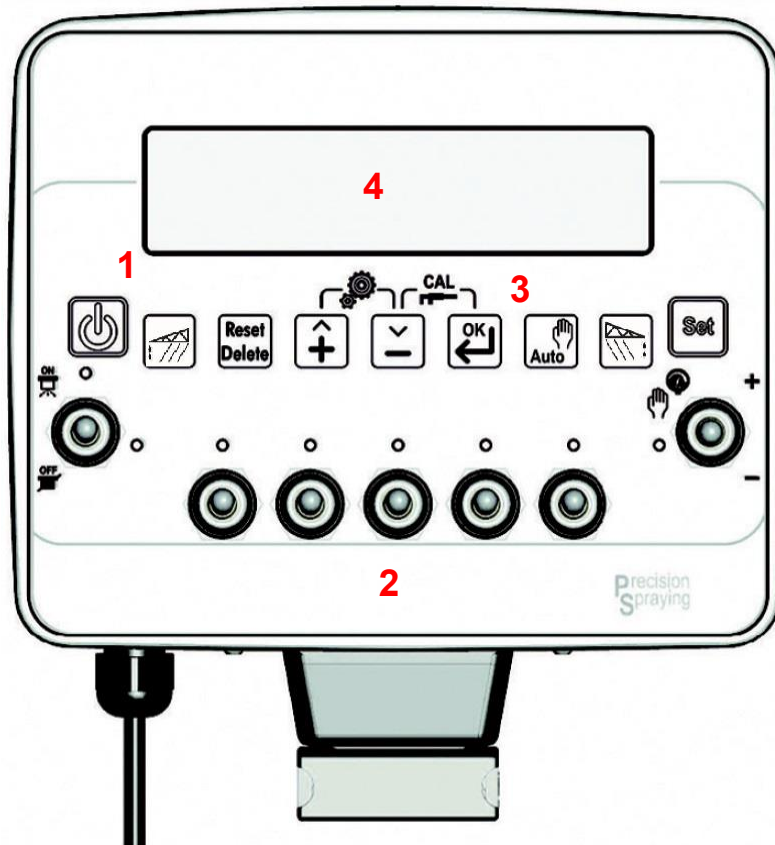
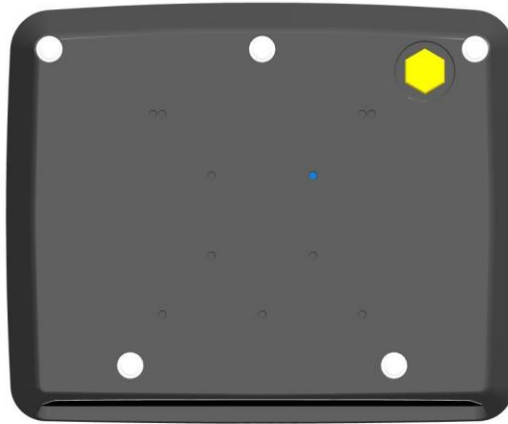

Picture 4 - Back side of the indicator



Application zone of self-adhesive labels with production codes, model and serial number.

10.1.2 Layout of the switches

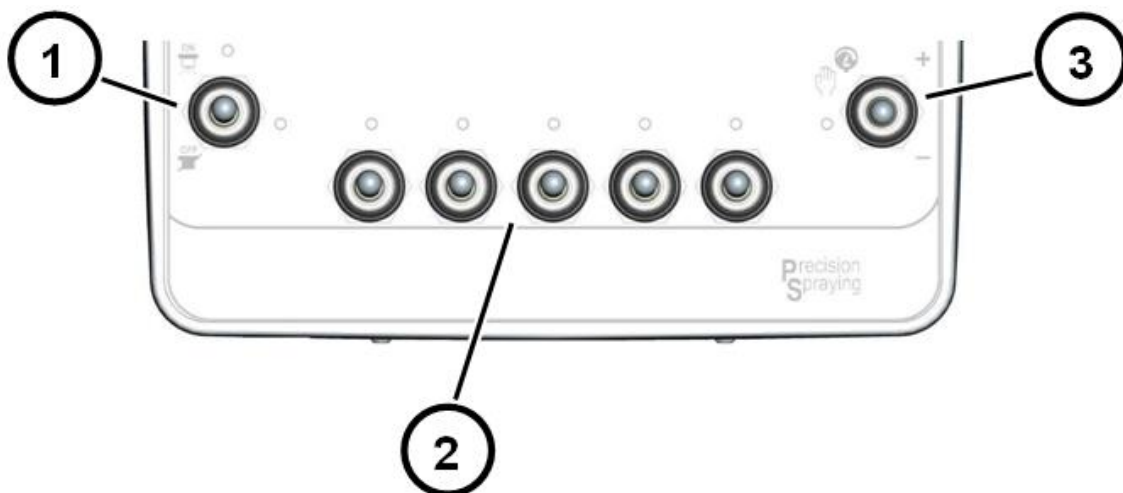

Picture 5 - Layout of the switches

- 1. Control switch of the general valve
- 2. Control switches of the section valves
- 3. Volumetric valve command.

10.2 CONNECTIONS SCHEME

10.2.1 Indicator GeoSystem 240 5 sections Crop Sprayer (CS)

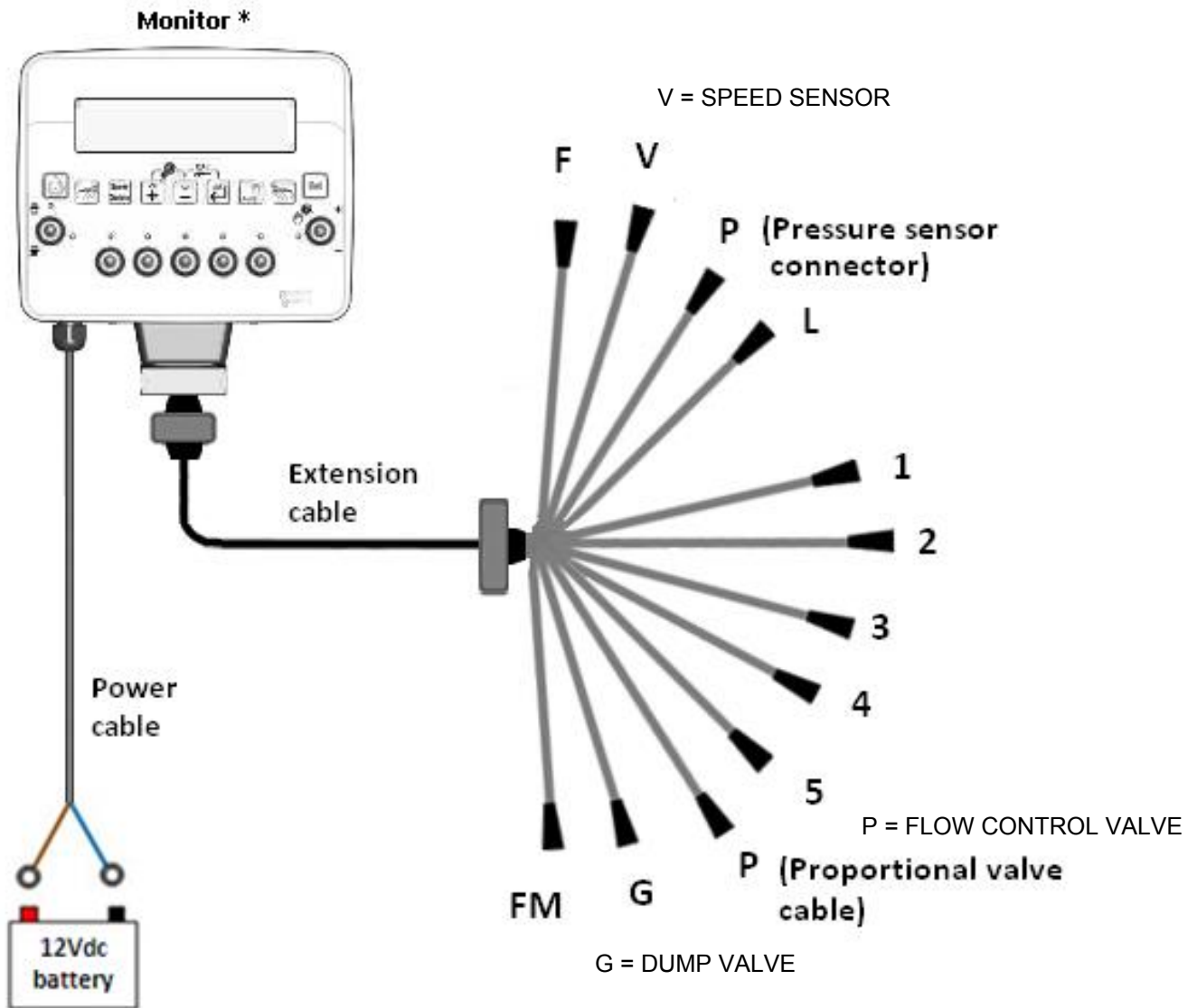

* Reference product configuration table



* 1-5 Section valves cables

F: Flow sensor

V: Speed advancement sensor

P: Pressure sensor

L: Tank level sensor

FM: Foam Marker

G: General valve cable

P: Proportional valve cable

Picture 6 - Scheme Crop Sprayer Version

ENGLISH

10.3 COMPUTER INSTALLATION

10.3.1 Advice for the location

The computer GeoSystem must be positioned in the command cabin of the farm vehicle taking care to observe the following precautions:

- Make sure that the monitor is not placed in areas subject to vibrations or crashes, this could damage the equipment or activate the buttons unintentionally;
- Fix the device in a place that is visible and easy to reach with your hands.
- The monitor should not obstruct the movement or limit the control visibility.

10.4 SPEED SENSOR INSTALLATION

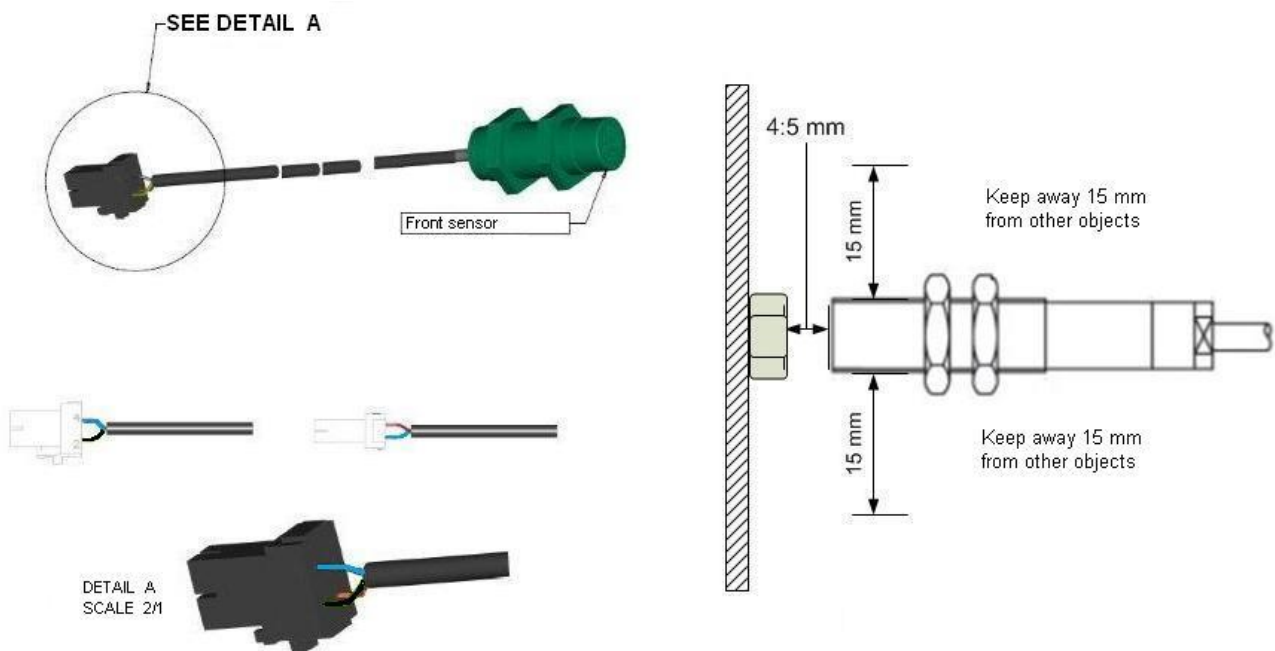

Color	Unsheathe	Termination	Connection point
Blue	30 mm	Stripped 4 mm	4
Brown	30 mm	Stripped 4 mm	1
Black	30 mm	Stripped 4 mm	2

Picture 8 - Proximity Installation

10.4.1 Advice for the location

The speed sensors must be positioned taking care to observe the following precautions:

- Install the sensor at 4-5 mm away from the body to detect;
- Do not install the sensor body too near to other metal objects that may affect the operation of the detector.

ENGLISH

10.5 FOAM MARKER CONNECTION CROP SPRAYER VERSION (CS)

FOAM MARKER

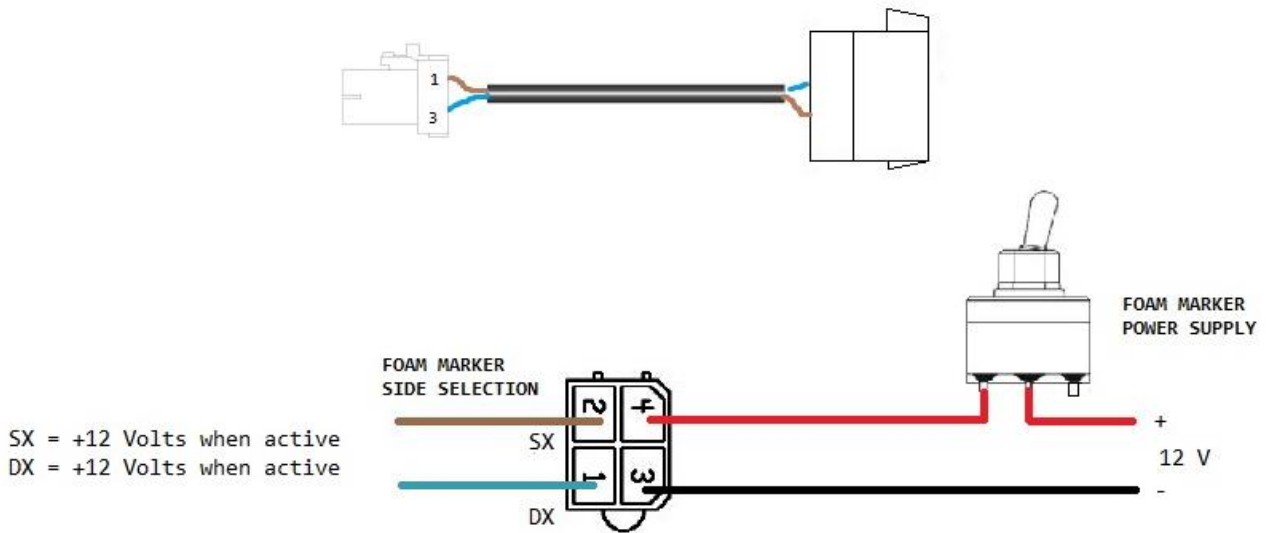

The indicator can not supply directly the foam marker because of its too high power consumption. It is necessary a designed accessory.

Picture 9 - Connection with the Foam Marker

10.6 FLOWMETER INSTALLATION

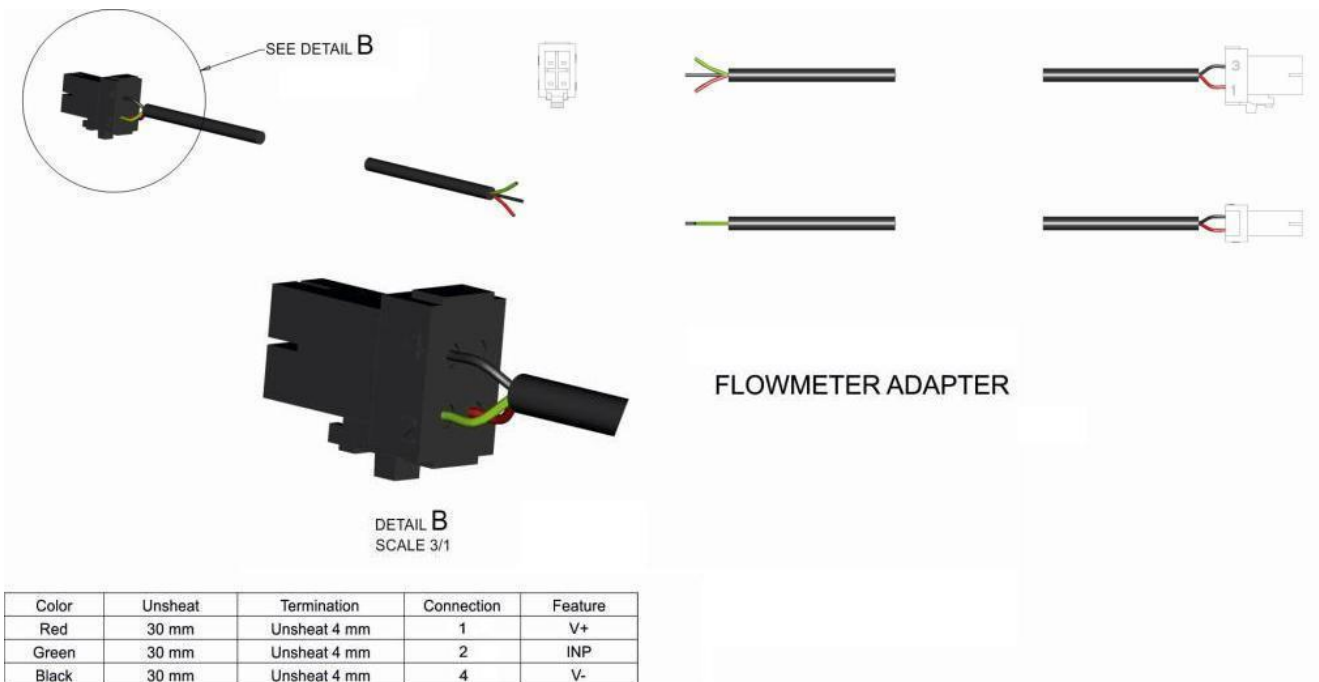

Picture 10 - Flowmeter Installation

10.7 CHECK HARDWARE INSTALLATION

Before to start with the use of GeoSystem 240 check the correct installation of each component:

- Check that the connectors are in the right locations
- Check that the cables have the right length
- Check that all screws are tight
- Check the polarity and the supply voltage

GeoSystem must be powered directly from the battery, it must not be connected to an outlet controlled by a master key.



In case of use of groups of valves equipped with a calibrated return, the correct functioning of GeoSystem is guaranteed only by an accurate calibration of all sensors and a proper calibration of the return flows.

11 INTERFACE DESCRIPTION OF CROP SPRAYER (CS) INDICATOR

11.1 TABLE LIST OF BUTTONS AND SWITCHES AND THEIR FUNCTIONS

Monitor with alphanumeric display, buttons and command switches

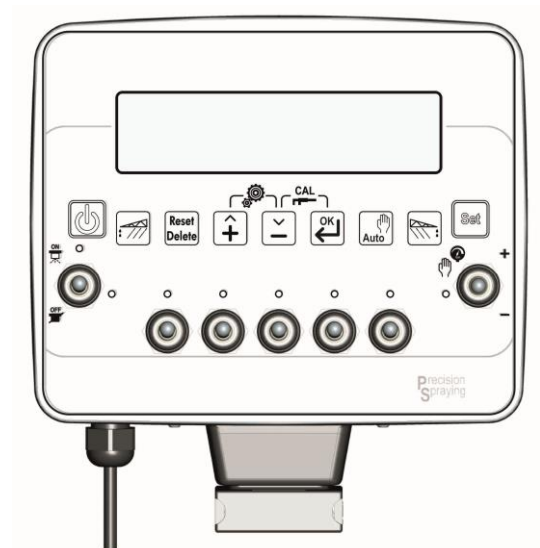

Picture 11 – Indicator

CONTROL KEYS, SELECTION OR MODIFICATION

ON / OFF key:

Turn on / off the indicator



Activation key foam marker:

Enable / disable the outputs marker on the left side of the vehicle, during the phase of operation (active energy)



Key command:

- Allows to returns to the previous menu
- Resets the percentage of increase / decrease of the value distribution
- Allows to reset the counters of the current treatment



UP key:

- It flows through the individual entries to the previous menu
- Increase the value of the parameter

During the modification of parameters, pressing the button permit to increase quickly the input values



DOWN key:

- Scrolls through the individual items through to the next menu
- Decrease the value of the parameter

During the modification of parameters, pressing the button permit to decrease quickly the input values



Confirm key:

- Confirms the access to the selected menu or parameter value previously modified
- Holding down this button for more than 2 seconds, it permit to display the values of the stored treatments



Command key:

Enable / disable the automatic adjustment of the distribution



Activation key foam marker

Enable / disable the outputs marker on the right side of the medium, during the operation phase (active energy).



Command key:

Allows to enable the menu of the working parameters.



Switch for the command of the control valve:

- in order to increasing the amount of liquid to be distributed, place the switch upward

manual function: increase the amount of liquid to be distributed

automatic function: increase the amount of liquid to be distributed at intervals of 10% respect to the set value



- in order to decreasing the amount of liquid to be distributed, place the switch downwards

manual function: decrease the amount of the liquid to be distributed

automatic function: decrease the amount of the liquid to be distributed at intervals of 10% respect to the set value.

11.2 MENU STRUCTURE

GeoSystem 240 menu are shown in the figure, in order to enter in the various items press the buttons or combinations of buttons located on the front panel of the monitor.

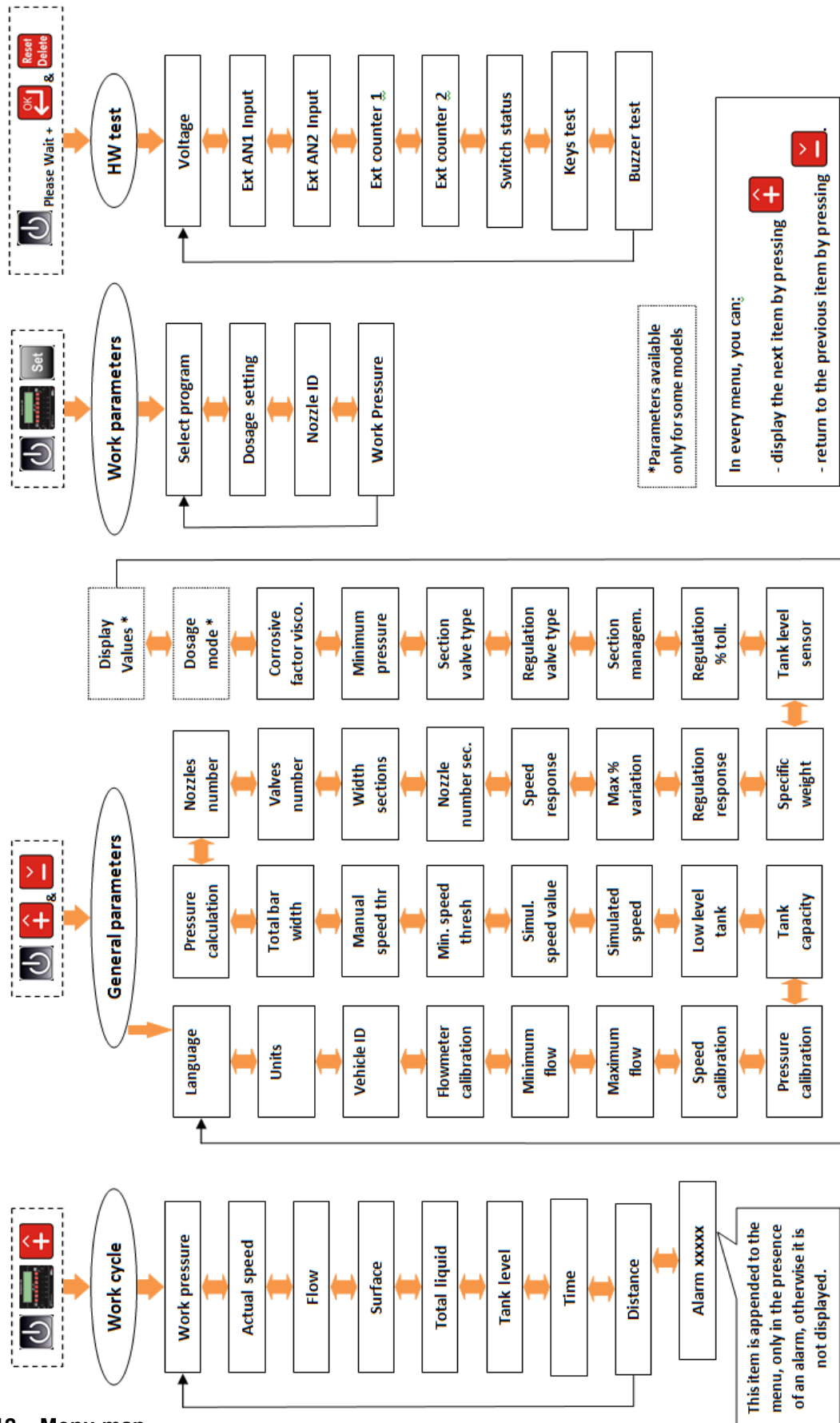













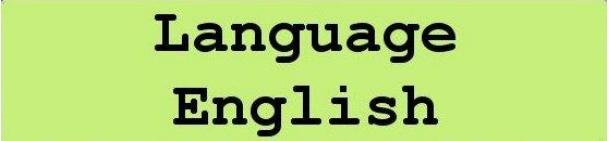

Figure 12 – Menu map

11.3 CONFIGURATION GENERAL PARAMETERS

Allows to set the parameters necessary for the proper operation of the indicator.

<p>1</p>  <p>Turn on by pressing</p>	
<p>2 The first message "GEOLine GeoSystem 240" will appear on the display.</p>	
<p>3 It shows the Firmware revision and the system name.</p>	
<p>4 Then, it appears the message "Please Wait".</p>	
<p>5 The working values appear.</p>	
<p>6</p> <p>Keep pressing simultaneously  and  in order to enter in the configuration menu.</p>	
<p>7 Scroll through the menu items using the  and  keys.</p>	
<p>8</p> <p>Press the  key in order to modify the parameter: through the  and  keys is possible to change the value.</p>	



If the fields contains default values or names, they will be displayed recursively by

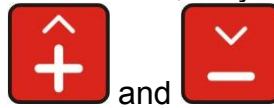

pressing and keys.

If the input value is numeric, it will be increased or decreased according to the duration of the key press with an exponential interval.



It is possible to cancel the current selection or return to the previously menu by



pressing the key.

11.3.1 LIST OF MENU ITEMS OF GENERAL CONFIGURATION

<p>1 Language: Italian/English/Spanish/French/German/ Portuguese/ Finnish/ Ukrainian/Russian/Polish.</p>	<p>Language English</p>
<p>2 Units of measure: - Metrics (l/ha, Km/h, bar): PRESSURE = 99.9 DISTRIBUTION = 99999 - US (GPA, mph, psi): PRESSURE = 9999 DISTRIBUTION = 999.9</p>	<p>Units Metrics</p>
<p>3 Vehicle identification: (1-5) it identifies the vehicle on which the system is installed.</p> <div style="text-align: center; margin: 10px 0;"> </div> <p>* By entering this configuration, you set the parameters for that particular vehicle (in this example: vehicle 1).</p>	<p>Vehicle ID 1</p>
<p>4 Flowmeter calibration: It specifies how many pulses arrive to the flowmeter per amount of liquid sprayed. 1-5000 pulse/liter (Metric) or pulse/USG (gallon) (US). The value is indicated in the label on the body or by manufacturer.</p>	<p>Flowmeter calib. 1000 imp/l</p>

<p>5 Alarm threshold minimum flow: 0-10000 l/min (Metric) or USGpm (gal/min) (US)</p>	<p>Minimum flow 98 l/min</p>
<p>6 Alarm threshold maximum flow: 0-10000 l/min (Metric) or USGpm (gal/min) (US) (l/min).</p>	<p>Maximum flow 10000 l/min</p>
<p>7 Speed sensor calibration: 2 mode: Constant wheel = distance traveled (cm or inches) / (number of pulses per revolution * wheel speed) or Automatic over a distance of 100 meters it is acquired pulse count.</p>	<p>Speed calib. 1000.0 cm/imp</p>
<p>8 Sensor pressure calibration: 0-200 F.S. value (bar or psi).</p>	<p>Pressure calib. 200 bar</p>
<p>9 Tank capacity: 0-10000 liter (Metric) or USG (gal) (US).</p>	<p>Tank capacity 712 l</p>
<p>10 Alarm threshold minimum tank level: 0-10000 liter (Metric) or USG (gal) (US).</p>	<p>Low tank level 99 l</p>
<p>11 Simulated speed: Yes/No.</p>	<p>Simulated speed Yes</p>
<p>12 Simulated speed value: 0-50 Km/h (metric) or mph (U.S.)</p>	<p>Sim. speed value 10 km/h</p>
<p>13 Minimum speed threshold: 0-50 Km/h. Below this value, it stops the spraying.</p>	<p>Min speed thresh 0 km/h</p>
<p>14 Manual speed threshold: 0-50 Km/h. Below this value, it is not carried out the automatic management (only manual).</p>	<p>Manual speed thr 0 km/h</p>

15	Total boom width: 0.00- 100.00 mt.	Total boom width 100.00 mt
16	Pressure calculation: Yes/No.	Pressure calcul. Yes
17	Nozzles number: Total number of nozzles present on the sprayers. 0-1000.	Nozzles number 20
18	Number of section valves: 3/4/5	Valves number 3
19	Total width of the spray boom: it allows to define the width of individual sections of the sprayers. <i>More information to paragraph 13.4</i>	Width section 1 1.00 mt
20	Nozzle number section 1 (external): 0-200	Nozzle num.sec.1 5

Parameters related to individual partial widths:



<i>Number of section:</i>	Partial width1	Partial width 2
3	Required	Not required
4	Required	Required
5	Required	Required

Table 4 - Parameters individual partial widths

Parameters related to the number of nozzles per section:

<i>Number of section:</i>	Number of nozzle section 1	Number of nozzle section 2
3	Required	Not required
4	Required	Required
5	Required	Required

Table 5 - Number of nozzles per section

<p>21 Sensitivity to change in velocity: it changes the response time of the flow rate control in function of the speed, from the value 1 (fast) to the value 5 (slow). By increasing this value, you will increase the precision but you will reduce the speed variation.</p>	<p style="text-align: center;">Speed response 2</p>
<p>22 Maximum percentage variation increase/decrease of the flow rate: 10, 20, 30, 40, 50%.</p>	<p style="text-align: center;">Max % variation 30 %</p>
<p>23 Adjustment response: Allows you to vary the response time of the automatic adjustment. Auto: automatic, the system automatically varies the adjustment time according to the current conditions. Low: slow adjustment response time. In this mode, the adjustment is more accurate but slower to respond to changes. Average: average adjustment response time. High: long adjustment response time. In this mode the system is faster. Customized: Parameters reserved to the manufacturer. Do not use this setup unless otherwise specified.</p>	<p style="text-align: center;">Regul. Response Auto</p>
<p>24 Specific weight liquid tank: Only if the presence sensor level = YES, it allows to calculate the level of the tank in function of the specific weight of the liquid inside.</p>	<p style="text-align: center;">Specific weight 1.00</p>
<p>25 Presence sensor level: If you choose YES, the measured level is used in the replenishment procedure of the tank. If you choose NO, it shows the pre-setting value.</p> <p style="text-align: center;"></p> <p>Press the  button to fill in the new value.</p>	<p style="text-align: center;">Tank level sens. Yes</p>
<p>26 Percentage value of the display tolerance: It determines the sensitivity to display.</p>	<p style="text-align: center;">Regulat. % toll. 3</p>

27 Section management:

- It is dependent (D) if, by closing the general valve, the other valves are closed; the led are switch off with the switches in any position. By re-activating the general valve, the other valves are re-activated and the switches are in ON position
- It is independent (I) if the section valves stay opened also if the general valve is closed.

**Section managm.
D**

(D) is the Farmscan standard settings
** Master Off = Dump On & Sections all OFF

FARMSCAN STANDARD

28 Regulation valve type:
Bypass / Throttling

**Reg. valve type
Bypass**

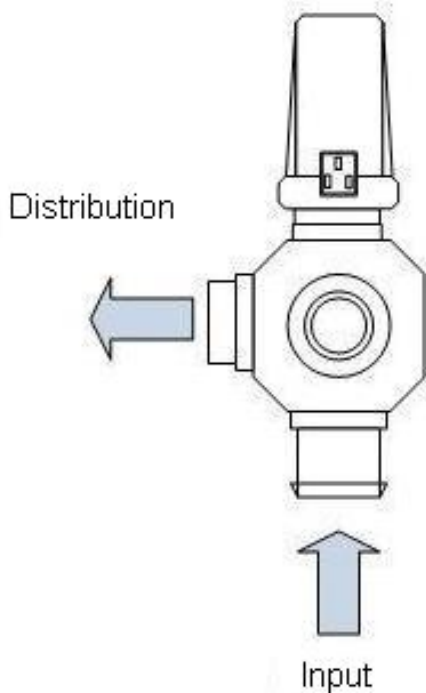

**Regulation valve type:
Throttling for
centrifugal pumps**

Picture 13 - Throttling

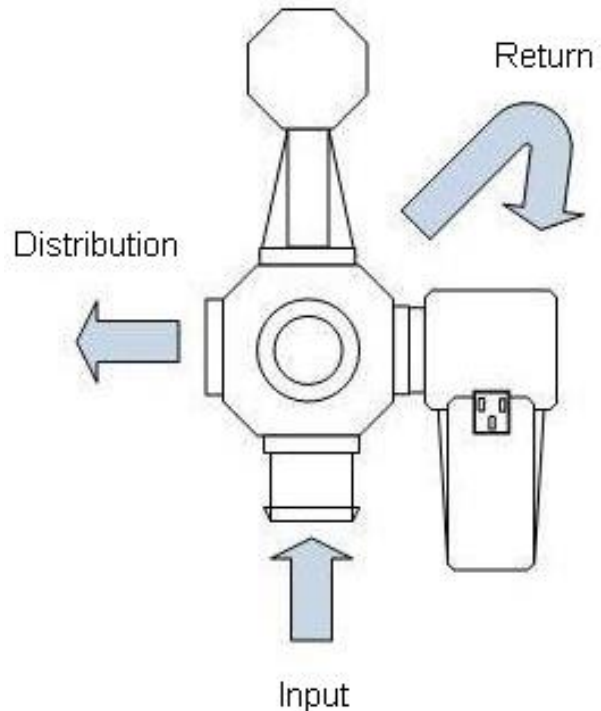

**Regulation valve type:
Bypass with return
to tank**

FARMSCAN STANDARD

Picture 14 - Bypass

29 Section valve type:
ON-OFF / Metered

**Sect. valve type
Metered**

FARMSCAN STANDARD
ON/OFF

30 **Minimum pressure:**
 0-200 bar
 After 15 seconds with a value below the minimum pressure, an alarm is generated.

Minimum pressure
100 bar

31 **Viscosity corrective factor:**
 Value of the corrective factor of the flow in function of the viscosity of the liquid.

Corr.fact.visco.
10.00

THE FOLLOWING PARAMETERS ARE AVAILABLE ONLY FOR SOME MODELS

32 **Dosage mode:**
 It is possible to change the unit of measure of dosage value.
 Surface/Distance.
 NOTE:
 If you set "Distance", the value represented shows a decimal value (if this value is less than 100).

Dosage mode
Surface



33 **Display values:**
 Main screenshot with 2 values (speed and distribution value) or with 4 values (speed, distribution, pressure and treated surface).

Display Values
2

Display Values
4

11.4 CONFIGURATION WORKING PARAMETERS

It allows to set all the working parameters of each single vehicle.

1  Turn on by pressing [].

2 The first message "GEOLine GeoSystem 240" will appear on the display.

GEOLine
GeoSystem 240

3 It shows the Firmware revision and the system name.

Rev. 1.0.4
Crop Sprayer

4 Then, it appears the message “Please Wait”.



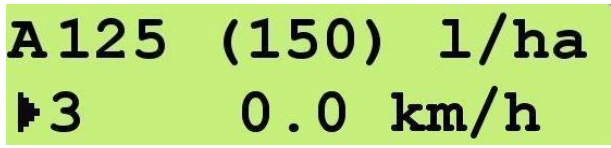

5 The working values appear.

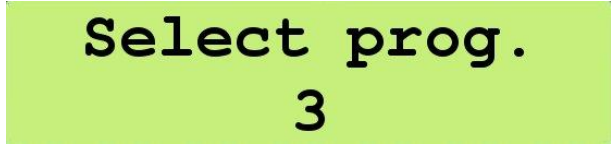

6  Press  key in order to enter in the working selection/configuration menu.



7 Press the  and  keys in order to choose the type of work and confirm pressing  key.



It is possible to configure and choose up to 10 different types of work.

8 Keep pressing again the  key to pass through the following programs.



It is possible to cancel the current



selection by pressing  key.

11.4.1 LIST OF ITEMS OF WORKING PARAMETERS

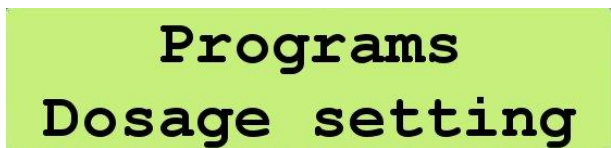
1 **Dosage setting:**
it permits to set the current value of the amount of liquid per unit of surface (liters per hectare).



2

Press the  button to enter in the parameter and to set the value using the  and  keys.



For some models, if you set "Distance" in the parameter "Dosage Mode", the value represented shows a decimal value (if this value is less than 100).

Dosage setting
100 l/ha

Dosage setting
10.0 l/hm

3 **Nozzle ID:**

It identifies the current nozzle.

For this parameter there are max 20 identifying marks divided in:

-ISO: 12 pre-configured identifying marks and

-USER: 8 identifying marks that can be personalized by the user. You have to insert the value for everyone: litres per minute and rated pressure.

See ISO table to paragraph 22



Programs
Nozzle ID

4

Press the  key to select the ISO or USER way.

Nozzle ID
ISO

5

Select the nozzle using the  and  keys.

Nozzle ID
ISO-01

6 **Work Pressure:**

Recommended speed in order to keep the set value of the pressure.

NOTE:

When you exit from the work parameters menu, the recommended speed appears for 3 seconds.

Work pressure
3.0 bar

Recommend. Speed
6.1km/h @ 3.0bar

<p>6 Alarm threshold maximum flow: 0-10000 l/min (Metric) or USGpm (gal/min) (US).</p>	<p>Maximum flow 10000 l/min</p>
<p>7 Speed sensor calibration: 2 mode: Constant wheel = distance traveled (cm or inches) / (number of pulses per revolution * wheel speed) or Automatic over a distance of 100 meters it is acquired pulse count.</p>	<p>Speed calib. 1000.0 cm/imp</p>
<p>8 Sensor pressure calibration: 0-200 F.S. value (bar or psi).</p>	<p>Pressure calib. 200 bar</p>
<p>9 Tank capacity: 0-10000 liter (Metric) or USG (gal) (US).</p>	<p>Tank capacity 712 l</p>
<p>10 Alarm threshold minimum tank level: 0-10000 liter (Metric) or USG (gal) (US).</p>	<p>Low tank level 99 l</p>
<p>11 Simulated speed: Yes/No.</p>	<p>Simulated speed Yes</p>
<p>12 Simulated speed value: 0-50 Km/h (metric) or mph (U.S.)</p>	<p>Sim. speed value 10 km/h</p>
<p>13 Minimum speed threshold: 0-50 Km/h. Below this value, it stops the spraying.</p>	<p>Min speed thresh 0 km/h</p>
<p>14 Manual speed threshold: 0-50 Km/h. Below this value, it is not carried out the automatic management (only manual).</p>	<p>Manual speed thr 0 km/h</p>
<p>15 Pressure calculation: Yes/No.</p>	<p>Pressure calcul. Yes</p>

<p>16 Number of section valves: 2, 4</p>	<p>Valves number 2</p>
<p>17 Sensitivity to change in velocity: it changes the response time of the flow rate control in function of the speed, from the value 1 (fast) to the value 5 (slow). By increasing this value, you will increase the precision but you will reduce the speed variation.</p>	<p>Speed response 2</p>
<p>18 Maximum percentage variation increase/decrease of the flow rate: 10, 20, 30, 40, 50%.</p>	<p>Max % variation 30 %</p>
<p>19 Adjustment response: Allows you to vary the response time of the automatic adjustment. Auto: automatic, the system automatically varies the adjustment time according to the current conditions. Low: slow adjustment response time. In this mode, the adjustment is more accurate but slower to respond to changes. Average: average adjustment response time. High: long adjustment response time. In this mode the system is faster. Customized: Parameters reserved to the manufacturer. Do not use this setup unless otherwise specified.</p>	<p>Regul. Response Auto</p>
<p>20 Specific weight liquid tank: Only if the presence sensor level = YES, it allows to calculate the level of the tank in function of the specific weight of the liquid inside.</p>	<p>Specific weight 1.00</p>
<p>21 Presence sensor level: If you choose YES, the measured level is used in the replenishment procedure of the tank,. If you choose NO, it shows the pre-setting value.  Press the button to fill in the new value.</p>	<p>Tank level sens. Yes</p>

22 **Percentage value of the display tolerance:**

It determines the sensitivity to display.
0 - 20 %

Regulat. % toll.
3

23 **Section management:**

- It is dependent (D) if, by closing the general valve, the other valves are closed; the led are switch off with the switches in any position. By re-activating the general valve, the other valves are re-activated and the switches are in ON position
- It is independent (I) if the section valves stay opened also if the general valve is closed.

Section managm.
D

24 **Regulation valve type:**

Bypass / Throttling

Reg. valve type
Bypass

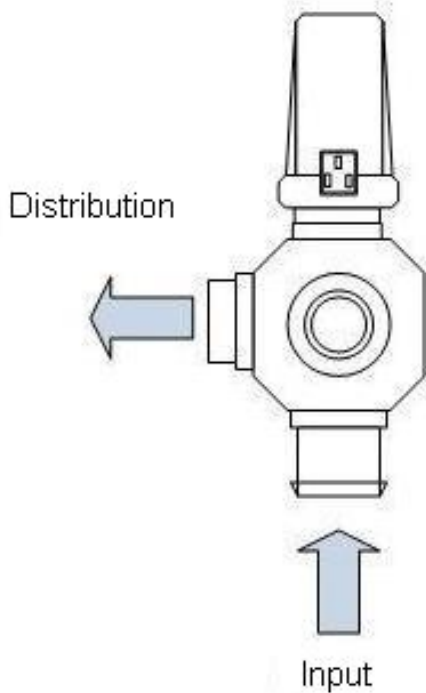

**Regulation valve type:
Throttling for
centrifugal pumps**

Picture 17 - Throttling

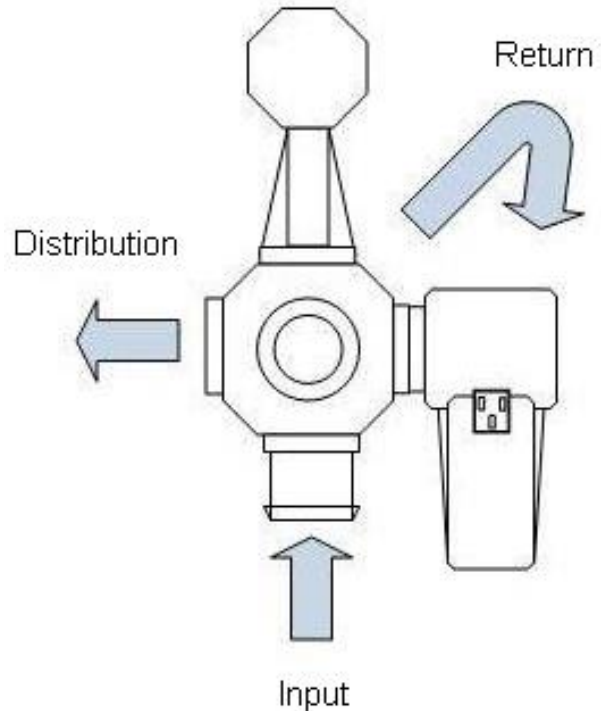

**Regulation valve type:
Bypass with return
to tank**

Picture 18 - Bypass

25 Section valve type: ON-OFF / Metered	Sect.valve type Metered
26 Minimum pressure: 0-200 bar After 30 seconds with a value below the minimum pressure, an alarm is generated..	Minimum pressure 100 bar
27 Viscosity corrective factor: Value of the corrective factor of the flow in function of the viscosity of the liquid.	Corr.fact.visco. 10.00
28 Regulation mode: It is possible to change the mode of automatic regulation of distribution: Constant pressure or Constant volume. <i>More information to paragraph 13.6</i>	Regulat. mode Constant press
29 Dosage mode: It is possible to change the unit of measure of dosage value. Surface/Distance. NOTE: THIS PARAMETER IS AVAILABLE ONLY FOR SOME MODELS. If you set "Distance", the value represented shows a decimal value (if this value is less than 100).	Dosage mode Surface

12.4 CONFIGURATION WORKING PARAMETERS

It allows to set all the working parameters of each single vehicle.

1  Turn on by pressing	
2 The first message "GEOLine GeoSystem 240" will appear on the display.	GEOLine GeoSystem 240
3 It shows the Firmware revision and the system name: Orchard Sprayer.	Rev.1.0.4 Orchard sprayer

4 Then, it appears the message “Please Wait”.



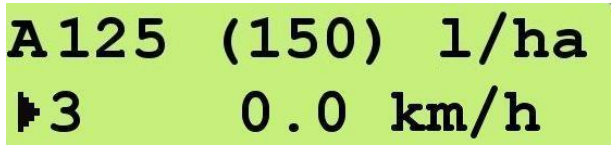

5 The working values appear on the display.

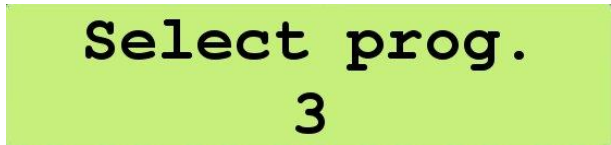

6 Press  key in order to enter in the working selection/configuration menu.



7 Press the  and  keys in order to choose the type of work and confirm pressing  key.



It is possible to configure and choose up to 10 different types of work.

8 Keep pressing again the  key to pass through the following programs.





It is possible to cancel the current selection by pressing  key.

12.4.1 LIST OF ITEMS OF WORKING PARAMETERS

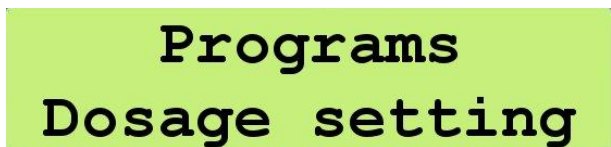
1 **Dosage setting:**
it permits to set the current value of the amount of liquid per unit of surface (liters per hectare).



2

Press the  button to enter in the parameter and to set the value using the  and  keys.



For some models, if you set "Distance" in the parameter "Dosage Mode", the value represented shows a decimal value (if this value is less than 100).

Dosage setting
118 l/ha

Dosage setting
10.0 l/hm

3 **Row Width:**

It allows to set the value of row width in function of corresponding value.

Programs
Width row

Width row
10.00 mt

4 **Boom:**

It allows to set the identifier of the boom. You can choose the value from "A" to "J"



If the parameter "Number of Valves" is equal to 4, the voices relating to Boom are 2:

1. Boom Type (1-4)
2. Boom Type (2-3)

More information to paragraph 13.5

Programs
Boom Type

Boom Type
A

Programs
Boom Type (1-4)

13 UTILIZZO DEL SISTEMA

13.1 EXECUTION WORKING CYCLE

It concerns the data management during the operating cycle. The indicator performs, according to the parameters configured, the acquisitions of the measures on the various sensors and the adjustment required.

1



Turn on the indicator by pressing

2 The current dosage values appear and, in parentheses, those specified. In the bottom line the speed of advancement of the vehicle.



This visualization is available during the work.

3



The indicator displays the single values measured and calculated through



and



keys.

13.1.1 LIST OF AVAILABLE VALUES IN THE WORKING CYCLE

1 **Current value of the pressure**

It is displayed only in this situations:

- Value of pressure calibration ≠ 0
- or
- Calculation of the pressure = YES

Pressure
0.0 bar

2 **Current value of the speed**

Speed
10.0 km/h

3 **Current value of the flow rate in liters / minute (or gallons / minute)**



The sign “@” indicates that the represented flow value is calculated and it is not originate from the reading of the specific sensor. This happens if and only if the parameter “Section valve type” is set as “Metered”.

Flow
0.0 l/min

Flow
@ 16.0 l/min

4 **Extension of the treated area since the beginning of treatment**



Surface
13.93 ha

5 **Total of the liquid sprayed since the beginning of treatment**

Total liquid
23 l

6 **Current level of the tank:**
this parameter allows to do the 2 following operations.

Tank level
7 l

Press the  key if you want to modify the tank value using the  and  keys.

Modif.tank level
1090 l

Press again the  key to confirm the value.



During the increase of the value, if you keep pressed the  key without releasing it, the value will increase and after 30 units it will pass to tens to accelerate the operation.



Keeping pressed the **Reset Delete** key for 5 seconds to set the initial tank capacity (see the Tank Capacity parameter).

If the level sensor parameter is YES the value set will be the level measured by the sensor. After the 5 seconds a message appears : Completed!

Press for 5 sec.
to set full tank

Completed!

7 **Duration of the last treatment (hh:mm)**

Time
01:46

8 **Traveled distance since the beginning of the last treatment (Km)**

Distance
17.83 km

9



At the end of the menu, you return to the initial display of the current dosing and those specified.

A125 (150) 1/ha
3 0.0 km/h

10



Press and hold the **Reset Delete** key for 5 seconds in order to reset, anytime, all counters related to the ongoing treatment.

After the 5 seconds, a message appears: Completed!



Release the **Reset Delete** key before the 5 seconds to cancel the reset.

Press for 5 sec.
to reset treat.

Completed!

13.2 WAY OF CALIBRATION

These operations must be carried out when the treatment is not active (in manual mode and with all the switches in the OFF position).

- NOZZLE CALIBRATION:

It allows to define the characteristics of the type of nozzle used (liter/minute) in function of the pressure (bar). It is possible to choose from a set of pre-configured identifying marks (ISO standard) or to define new ones.

- TANK LEVEL CALIBRATION:

It sets the calibration points related to the level sensor of the tank.

- SPEED SENSOR CALIBRATION:

It calculates the rate constant based on a known distance to travel (100 m in EU and 300 feet in US).

- 1 Turn on the indicator by pressing



- 2 Keep pressing simultaneously



Slide the 3 voices of calibration through



- 3 **NOZZLE CALIBRATION** (max 8).

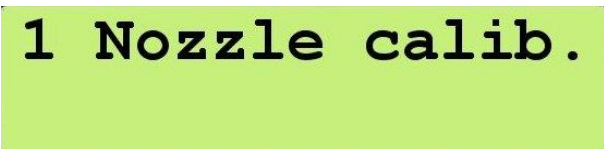



- 4 Press the  key to enter in the nozzle configuration.

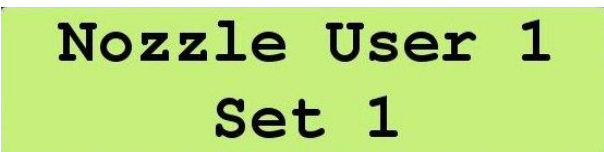

- 5 Press again the  key to set up to 5 pairs of calibration values (Set 1-5) related to the nozzle.



6

Press again the  key to set the Pressure and the Flow Rate using the  and  keys.

Pressure
0.0 bar

Flow
0.0 l/min

7

Press the  key in order to return to the previous menu.

8

TANK LEVEL CALIBRATION

2 Tank level cal

9

Press the  key in order to enter in the tank configuration and to set the calibration points.

Tank level
Points number 2



It is possible to define a minimum of 2 calibration points up to a maximum of 25.

Tank level
Points number 25

10

Press again the  key in order to insert the Tank level in liters using the  and  keys.

Tank level 1
75 l



Pour clean water (in the previously fitted amount of it) into the tank and confirm it

with the  key in order to move to the next value.

11 Definition of the second value.
 Completely repeat the operations of the step 9.

Tank level 2
200 1

12



Perform the steps 9 and 10 until the definition of all the calibration points you want to set (max 25).

13



Press the  key in order to finish the calibration.

If everything is successful, it appears the message "Completed!".

Completed!

14 **SPEED SENSOR CALIBRATION**

3 Speed calib.

16 The message "Counter value" appears, it will increase as the tractor moves towards the finish line.

Counter value
0

17



Press the  key when the tractor crossed the line (100 m in EU and 300 feet in US) in order to complete the calculation of the speed constant.

Completed!

18



Press the  key to enter into the calibration.

13.3 VALUE OF SOFTWARE PARAMETER

Limit values of the setting software parameters.

Parameter	Description	Min. / U.M.		Max. / U.M.		Note	
Language	Message language	ENG/ITA/SPA/DEU/ FRA/POL/RUS/FIN/POR					
Unit	Used metric system	l/ha, Km/h, bar o GPA, mph, psi				Metrics/US	
ID Vehicle	Vehicle on which the system is installed	1		5			
Flowmeter Calibration	Constant Flowmeter Value	1 imp/l	4 imp/USG	5000 imp/l	18927 imp/USG	Metrics/US	
Minimal flow	Alarm threshold minimum flow	0 l/min	0 USGpm	10000 l/min	2642 USGpm	Metrics/US	
Maximum flow	Alarm threshold maximum flow	0 l/min	0 USGpm	10000 l/min	2642 USGpm	Metrics/US	
Speed Calibration	Speed sensor calibration	0.0 cm/imp	0.0 in/imp	6000.0 cm/imp	2362.2 in/imp	Round pulse Num. * wheel rounds	
Pressure Calibration	Pressure sensor calibration	0 bar	0 PSI	200 bar	2901 PSI	Value of bottom scale	
Tank capacity	Value the tank can contain	0 l	0 USG	10000 l	2642 USG	Metrics/US	
Minimum Tank level	Alarm threshold minimum level tank	0 l	0 USG	10000 l	2642 USG	Metrics/US	
Simulated speed	Simulated speed	No		Yes			
Simulated speed value	Simulated speed value	0 km/h	0 mph	50 km/h	31 mph	Metrics/US	
Threshold minimal speed	Value below which the spraying action is interrupted	0 Km/h	0 mph	50 Km/h	31 mph	Metrics/US	
Threshold manual speed	Value below which the automatic management is not effectuated	0 Km/h	0 mph	50 Km/h	31 mph	Metrics/US	
Boom total width (CS)	Boom total width	0.00 mt	0.00 ft	100.00 mt	328.08 ft	Metrics/US	
Pressure calculation	Pressure calculation	No		Yes			
Number of nozzle (CS)	Number of nozzle	0		1000			
Number of valve (CS)	Number of valve	3		5		3, 4, 5	
Number of valve (OS)	Number of valve	2		4		2, 4	

Width section 1 (CS)	Partial width of the boom	0.00 mt	0.00 ft	25.00 mt	82.02 ft	Metrics/US
Width section 2 (CS)	Partial width of the boom	0.00 mt	0.00 ft	25.00 mt	82.02 ft	Metrics/US
Number of nozzle section 1 (CS)	Number of nozzle external section	0		200		
Number of nozzle section 2 (CS)	Number of nozzle internal section	0		200		
Speed response	Sensitive to the speed variation	1		5		1 fast 5 slow
Variation Max %	Variation Max % increase/decrease of the flow rate	10 %		50 %		
Adjustment response	Response time of the automatic adjustment	Auto / Low / Medium / High / Custom				
Specific weight	specific weight of tank liquid	0.00		10.00		
Level sensor	Level sensor	NO		Yes		
% tolerance of regulation	Value % of tolerance	0 %		20 %		
Sections management	Sections management	D		I		
Regulation valve	Type regulation valve	Bypass		Throttling		
Section valve	Type section valve	On-Off		Calibrated		
Corrective viscosity factor	Corrective viscosity factor	0.00		10.00		
Regulation mode (OS)	Automatic regulation of distribution	Constant Pressure		Constant Volume		
Dosage mode	Unit of measure of dosage value	Surface		Distance		
Display Values (CS)	Visualization mode of the values on the display	2		4		

Table 6 - General Parameters

Parameter	Description	Min. / U.M.		Max. / U.M.		Note
Working selection	Type of work	1		10		
Dosage setting	Current value of the amount of liquid	0 l/ha	0 GPA	10000 l/ha	1069 GPA	Metrics/ US
ID nozzle	Identify the current nozzle	ISO or USER(CS) / ATR or MGA (OS)				
ISO (CS)	ISO nozzle	ISO-01		ISO-20		12 pre-configured
USER (CS)	USER nozzle	User 1		User 8		8 personalised
ATR (OS)	ATR nozzle	ATR-White		ATR-Blue		10 pre-configured
MGA (OS)	MGA nozzle	MGA-White		MGA-Red		8 pre-configured
Work Pressure (CS)	It calculates the value of the recommended speed on the basis of the working pressure value	0.0 bar		6000.0 bar		

Table 7 - Working Parameters

13.4 SECTIONS' WIDTH CROP SPRAYER (CS)

For the proper functioning of GeoSystem 240 is not necessary to insert the width of each single section but it is sufficient to indicate the total boom width and the width of only one side of one sections.

The length of the sections will be calculated based on the symmetry of the system.

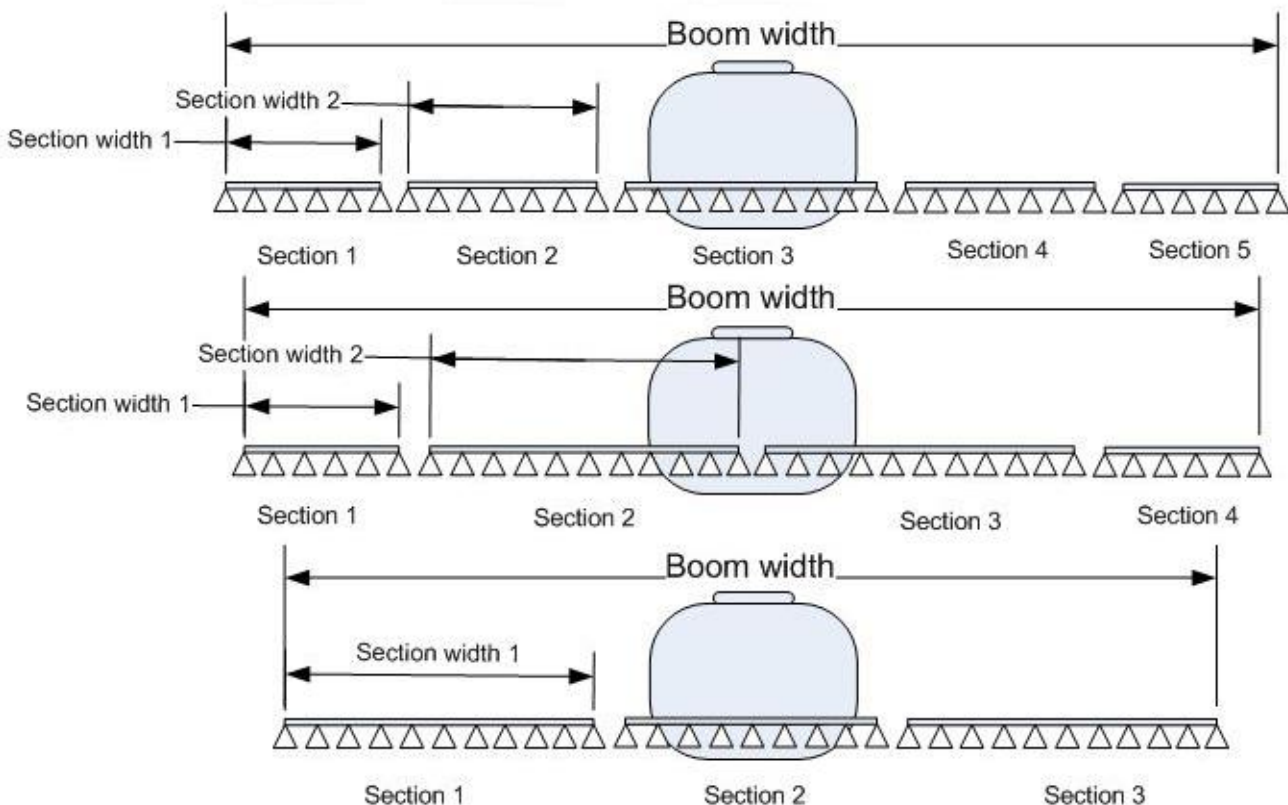

Picture 19 –Sections' width Crop Sprayer version (CS)

ENGLISH

14 HW TEST

It allows to effect the hardware test.



This test can be carried out only at starting.

1



Turn on the indicator by pressing .

2 After viewing the Firmware revision, when the message “Please Wait” appears, press simultaneously the



and



keys.

Please Wait

3 The message “Test HW” appears.

Test HW

4 The value of Voltage appears and it is possible to slide the following values



and



through  and  keys.

**Voltage:
12.11 V**

5 The next data is the value of the analog input 1 of the Switch Box board corresponding to the pressure sensor.



**Ext AN1 Input:
0.00 mA**

6 The next data is the value of the analog input 2 of the Switch Box board corresponding to the tank level sensor.



**Ext AN2 Input:
0.00 mA**

7 The next data is the value of the external counter 1 corresponding to the



input of the flowmeter 

**Ext counter 1:
0 Hz**

- 8 The next data is the value of the external counter 2 corresponding to the input of the speed sensor.



**Ext counter 2:
0 Hz**

- 9 The next data indicates the status related to the switches.

0 = OFF
1 = ON

By actuating the switches, the state will change from 0 to 1 and turning them off will return to 0.

**Switch status:
000000000000**

**Switch status:
111111001010**

- 10 This passage allows to check the correct functioning of the keys. The message "Press a key" will be displayed.

Press a key:

- 11 By keeping pressed a key, the name of the key appears temporarily on the display.

**Press a key:
ENTER KEY**



By pressing the Reset key, first the message "RESET KEY" appears; then the indicator goes on to the buzzer test.

- 12 Buzzer test.

During this passage an acoustic signal will be generated, confirming the correct functioning of the buzzer.

Buzzer ON!

- 13 Press any key to return to the keys test;



press the key in order to return to the normal operation of the indicator.

- 13



To repeat the TEST HW it is necessary to switch off and on again the indicator.

15 USE OF GEOSYSTEM 240

ENGLISH

15.1 DISPLAY CROP SPRAYER (CS) 2 VALUES

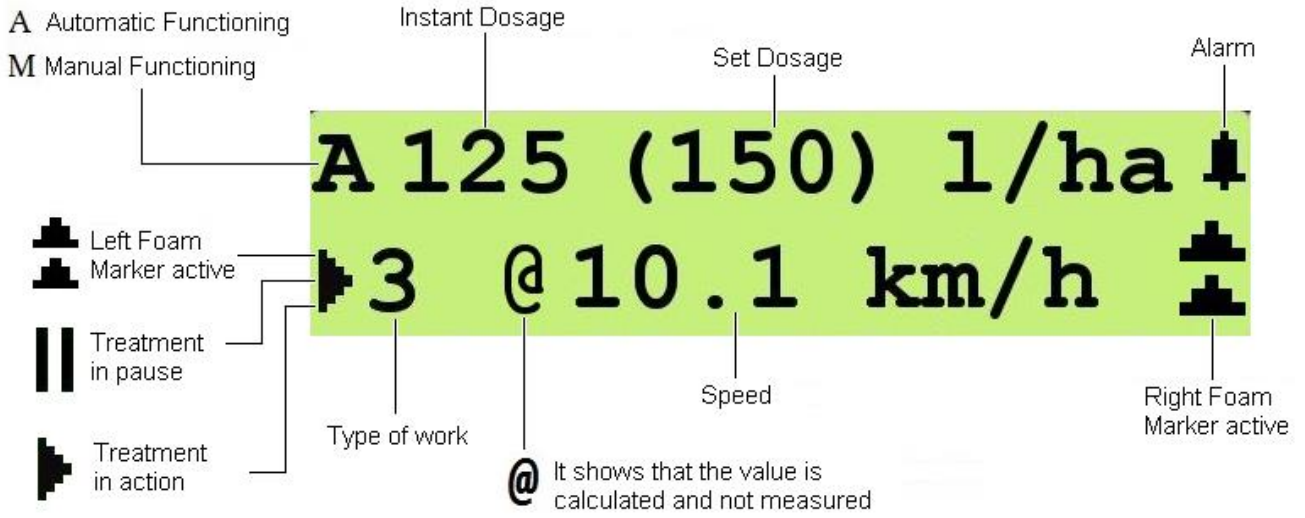

Figure 22 –Display Crop Sprayer 2 Values

15.2 DISPLAY CROP SPRAYER (CS) 4 VALUES

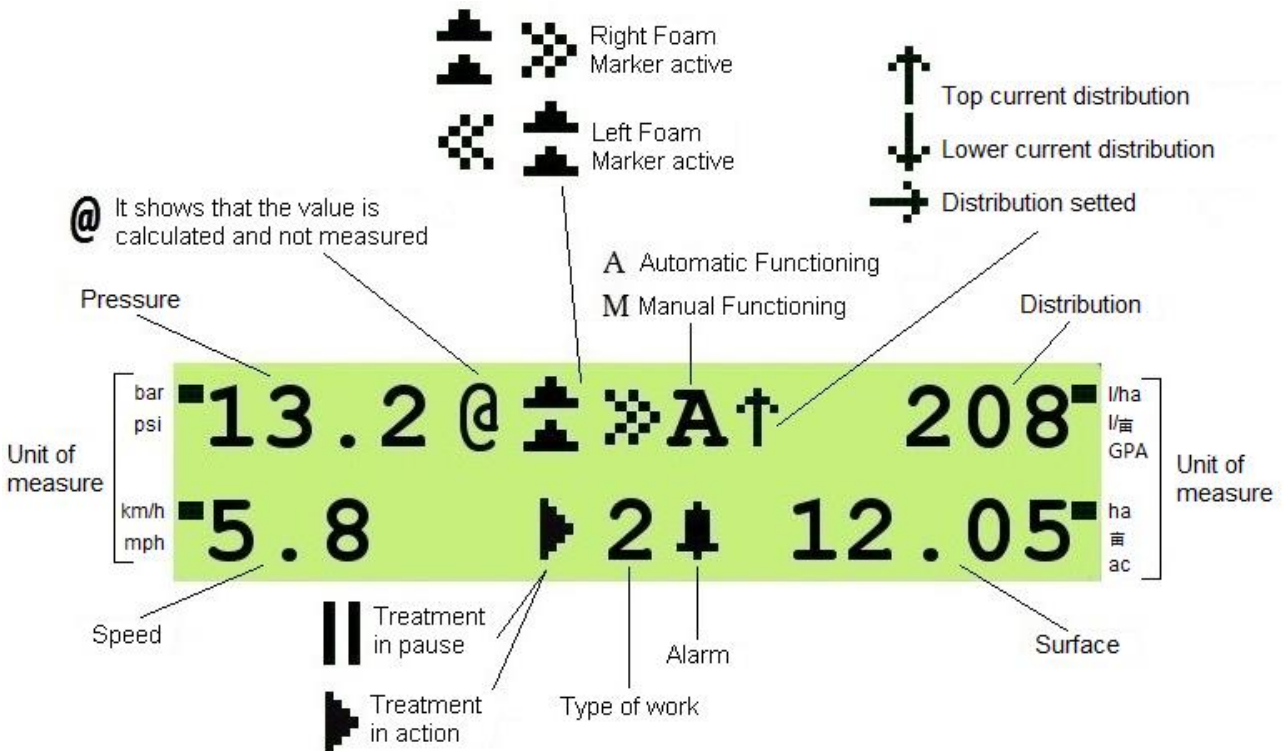

Figure 23 –Display Crop Sprayer 4 Values

15.3 DISPLAY ORCHARD SPRAYER (OS)



Figura 24 – Display Orchard Sprayer

15.4 DEFINITION OF TREATMENT

The term treatment means the set of data recorded during an activity of weeding or sprayer. The working parameters recorded by GeoSystem are stored in a tail. The tail can store a maximum of 20.

The data of each treatment can be visualized through the appropriate keys.

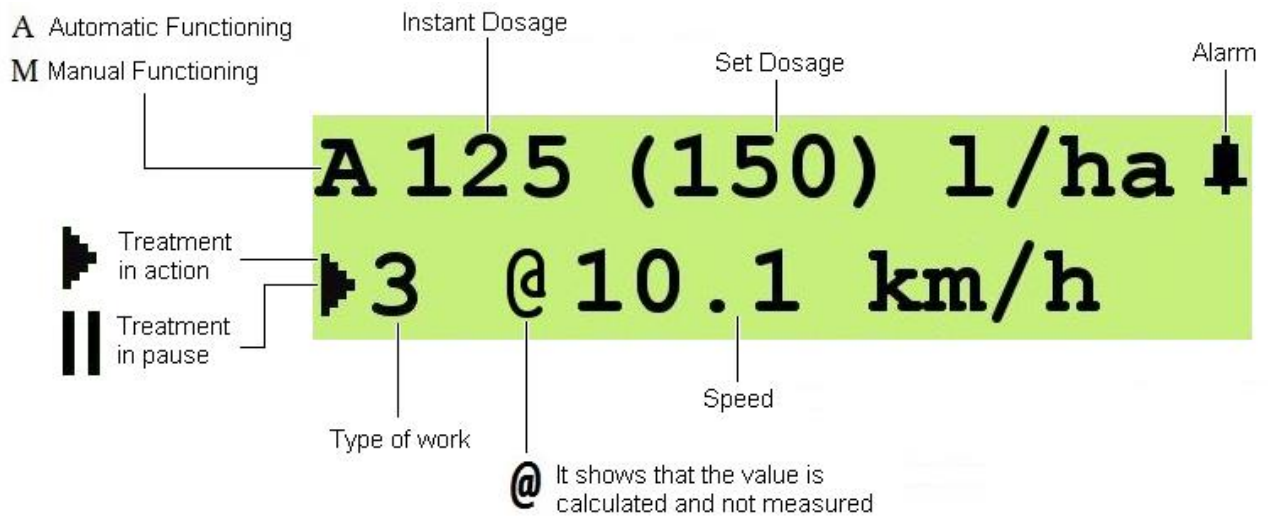
Every time you start a new treatment the data of the current treatment are inserted in the tail.

The treatment number 1 is the last treatment saved.

Treatment number 2 is the second last treatment saved and so on.

All treatments inserted in the queue slip of a position at the moment of every saving.

When the tail is full, the recording of a new treatment causes the cancellation of the treatment less recent (that in twentieth position).

After the treatment n° 20, appears the value "Total", that refers to the historical data related to all the treatments.



This value cannot be deleted, not even through the RESET procedure.

15.5 NEW TREATMENT

- 1 To start the recording of data on a new treatment, select a parameter of any work cycle, with the exception of the parameter: "Tank Level".

- 2  Press the **Reset Delete** key for 5 seconds.

- 3 By now, the counters are all reset.



The parameter "Tank level" is a special parameter:

If it is selected, the pressing of the button for 5 seconds DO NOT prepare the system for a new treatment but for a new filling of the tank.

15.6 TURNING ON GeoSystem 240

- 1 Turn on the indicator by pressing



- 2 The first message "GEOLine GeoSystem 240" will appear on the display.

**GEOLine
GeoSystem 240**

- 3 It shows the Firmware revision and the system name.

**Rev. 1.0.4
Crop Sprayer**

- 4 After which it appears the message "Please wait"

Please Wait

- 5



If the general valve is active (switch in ON position),when you are turn on the indicator, it will appear a message and then a sound of the buzzer to demand your attention.

Disable the switch to interrupt the alarm.

**WARNING!
Gen.valve is on**

6	The working values appears on the display and, eventually, additional markings such as:	
7	<ul style="list-style-type: none"> the character “M” before the current value of distribution “M 125 l/ha”: it signals that the indicator is in manual mode; 	
8	<ul style="list-style-type: none"> the character “A” before the current value of distribution “A 125 l/ha”: it signals that the indicator is in automatic mode. 	
9	<ul style="list-style-type: none"> the sign “▶” at the bottom left: it signals that the treatment is in action. 	
10	<ul style="list-style-type: none"> the sign “ ” at the bottom left: it signals that the treatment is in pause. 	
11	<ul style="list-style-type: none"> the number “3” at the bottom left: it identifies the type of work you are doing. 	
12	<ul style="list-style-type: none"> the sign “@”: it indicates that the data represented on the right is calculated or simulated and it is not originated from the reading of one specific sensor. E.g. the represented speed is a simulated value. 	
13	<ul style="list-style-type: none"> The symbol  in the upper right: it indicates the presence of an alarm. 	

14 CROP SPRAYER VERSION (CS):



- The symbol  in the bottom left / right: it indicates that the foam marker is active.



It is possible to enable this option by



pressing  and  keys.
Press again to turn it off.

M 125 l/ha
 10.1 km/h

15 CROP SPRAYER VERSION (CS):

At the starting, press simultaneously the



    keys to
reset all the parameters of the indicator
to the initial values.

Press ENTER to
reset all memory

ORCHARD SPRAYER VERSION (OS):

At the starting, press simultaneously the



    keys to
reset all the parameters of the indicator
to the initial values.

15.7 TURNING OFF GeoSystem 240

- 1  Press the  key for 2 seconds in order to turn off the system.

- 2 Wait that the data of the last treatment will be saved.





During the turning off do not press any key and do not remove the power, until the control unit turns off.

Always use the appropriate button to turn off the computer, otherwise all the data relating to treatments and schedules will be lost.

15.8 PREPARATION

- 1 Make sure all the switches are in OFF position.
- 2 Turn on the indicator by pressing the  key.
- 3 Set in GeoSystem the amount of the liquid that is in the tank.
- 4 To start the data recording of a new treatment, select a parameter of the any cycle work, with the exception of the parameter "tank level".
- 5 The system stores the treatment data in a tail of 20 elements.

- 6  Press for 5 seconds the  key to save the last data stored in the tail and to reset all the meters, prearranging the data recording of the new treatment you will do.

N.B. if the level sensor is not present, pressing the key, you will reset all the working data, except the tank level that is recharged to the pre-set value during the configuration phase.

**Press for 5 sec.
to reset treat.**

15.9 AUTOMATIC FUNCTIONING

The automatic functioning is indicated by the letter A, situated on the left side of the display. The value between parenthesis is the dosage set by the user, GeoSystem 240 will drive the regulation valve looking for maintaining constant the dosage at the variation of the vehicle speed.

15.10 MANUAL FUNCTIONING

The manual functioning is indicated by the letter M, situated on the left side of the display. GeoSystem 240 will record the working data shown during the functioning.

15.11 TANK REPLENISHMENT DURING A TREATMENT

1 If the field to treat requires an amount of liquid higher than the amount of the tank, it will be necessary to fill once or more times the tank.

2 At every replenishment you have to update the tank level (parameter: "Tank Level ")

3 Select the parameter: "Tank Level"

Tank level
7 1

4 Press for 5 seconds the  key.

Press for 5 sec.
to set full tank

5 Press the  key in order to set manually the quantity of liquid loaded on the tank.

Modif.tank level
500 1

6 The parameter is automatically updated with the maximum tank capacity value (parameter "Tank capacity").



Completed!



The parameter "Tank level" is a special parameter:

if you DO NOT select the parameter "Tank level" the pressure of the key for 5 seconds will prepare the system for a new treatment, resetting all the counters.

7 To modify the value, enter in modifying phase pressing the OK key and using

the  and  keys to increase or decrease the value.

15.12 TOTALIZERS

It allows to check the counters related to working.

15.12.1 READING TOTALIZERS

1

Turn on the indicator by pressing .

2

Press and hold the  key for 3 seconds to access the statistics of the operating mode.

**Press for 3 sec.
for totalizer**

3

Shows the name of the totalizer and, at the bottom line, the total duration of the treatment.

**Treatment 1
Duration 08:25**

4

Scroll the last 20 treatments through



The totalizer N° 1 relates to the treatment more recently while the totalizer N° 20 is the oldest one.

**Treatment 20
Duration 03:19**



5

After the treatment n° 20, appears the total value that refers to the historical data related to the treatments.

**Total
Duration 30:00**

6

Press the  key to verify the individual counts of each totalizer.

Through  and  keys, display the values relating to the treatment carried out, such as:

- The value of the treated area (ha)

**Surface:
13.93 ha**

- The value of the total liquid sprayed (l)

**Total liquid:
23 l**

- The traveled distance (Km)

**Distance
17.83 km**

<ul style="list-style-type: none"> • The duration of the treatment performed (hh:mm). 	<p style="text-align: center;">Time 01:46</p>
<ul style="list-style-type: none"> • Average speed (km/h) 	<p style="text-align: center;">Average speed 3.0 km/h</p>
<ul style="list-style-type: none"> • Maximum speed (km/h) 	<p style="text-align: center;">Maximum speed 6.0 km/h</p>



15.12.2 RESET TOTALIZERS

1 The indicator stored the data of treatment in a tail of 20 elements.

2

Press and hold the  key for 5 seconds in order to save the last data stored in the tail and in order to reset all counters, preparing the recording of the data related to the new treatment that will be performed.

**Press for 5 sec.
to reset treat.**

Press  key to confirm the reset or  key to cancel.



If the level sensor is not present, pressing the reset button will reset all work data, except the tank level, which is reloaded to the preset value during configuration.



15.13 RECALL DATA OF TREATMENTS

1

Press for 3 seconds the  key, in order to access to the menu that allows to visualize the tail of last 20 treatments performed.

**Press for 3 sec.
for totalizer**

2

Using the  and  keys in order to scroll the list of treatments. Press the  key in order to access to the content.

16 ALARMS

16.1 WARNING AND ALARMS

There are some warnings and alarms to highlight unusual states that show anomaly functioning.

At the activation of fan alarm, you will hear the buzzer.



Press  key to disable it.

The active alarm state is highlighted by the

sign  on the right of the first line of the display.

M 125 l/ha 
10.1 km/h

16.2 LIST OF POSSIBLE ALARMS

1. Flow regulation alarm:

the indicator has to reach a flow set point value (l/ha), if it can not reach this value, the indicator gives a signal after a minute.

Alarm 
flow regulation

2. Tank empty alarm:

it gives this alarm when it reaches the minimum flow of liquid in the tank set with the parameter.

Alarm threshold minimum tank level

Alarm 
tank empty

3. Minimum flow alarm:

The amount of sprayed liquid (l/min) is lower than the parameter value.

Alarm threshold minimum flow

Alarm 
minimum flow

4. Maximum flow alarm:

the amount of sprayed liquid (l/min) is higher than the parameter value.

Alarm threshold maximum flow

Alarm 
maximum flow

5. Low battery level alarm:

the battery level is lower than 9.0 Volts

Alarm: 
LOW BATTERY!

6. Low pressure alarm:

The alarm is generated after 15 seconds with a pressure less than the parameter

Minimum pressure

Alarm: 
low pressure

17 TROUBLESHOOTING

DISPLAY	CAUSE	SOLUTION
The display does not turn on	There is not power.	Check the connections on the power cable.
	The indicator is turned off.	Press the turning on button.
The valves can not be controlled	The valves are not connected.	Connect the connectors
A valve does not open	The valve has not power.	Check the electric connection and the functioning of the valve
The counting of the travelled distance shown on the computer is different from the real one.	Wrong programming	Check the connection with the speed sensor.
	The reset of the totalizer has not been effectuated	Reset the totalizer
The counting of the travelled surface shown on the computer is different from the real one.	Wrong programming	Check the boom width programming
	The reset of the totalizer has not been effectuated	Reset the totalizer
The instant pressure is not shown.	The indicator has not signal from the pressure sensor	Check the connections with the pressure sensor
	Wrong installation of the pressure sensor	Check the bottom scale programming for the pressure sensor
The instant pressure visualized is inaccurate.	Wrong programming	Check the bottom scale programming for the pressure sensor
	The pressure sensor is not calibrated	Do the calibration
	Wrong installation of the pressure sensor	Check the connections with the pressure sensor
The tank level visualized is inaccurate.	The level sensor is not calibrated.	Do the calibration. Repeat the level sensor calibration.
	Wrong installation of the level sensor.	Check the connection with the level sensor

Table 8 - Troubleshooting

18 OTHER CONFIGURATIONS CROP SPRAYER (CS)

18.1 EXAMPLE OF GeoSystem 240 5W CS INSTALLATION ON SPRAYED SYSTEM WITH 4 SECTIONS

1 Make sure the system is exactly connected as on picture 5 at page 9.

2 In this step it is not important the sensor connection but the valve cable connection and the GeoSystem 240 driver box output connection.

3 Make sure all the switches are in OFF position so turn on the indicator by



pressing the key.

4 The first message "GEOline GeoSystem 240" will appear on the display.

**GEOline
GeoSystem 240**

5 It shows the Firmware revision and the system name.



**Rev. 1.0.4
Crop Sprayer**



6 It appears the message "please wait"

Please Wait

7 It appears the working values.

**A125 (150) 1/ha
3 0.0 km/h**

8 Press simultaneously the  and  keys to enter into the configuration menu.

9 Scroll up and down the entries of the menu using the  and  keys to arrive at the parameter "number of valves".

**General config.
Valves number**

10 Press the  key to enter into the configuration.



Go to the next step to verify the operation of the valves otherwise skip to step number 15.

11

Set the number 5 and press the



**Valves number
X**

12

It appears a new message " General configuration Number of valves".

**General config.
Valves number**

13

Press the



key to exit and to launch again the indicator.

14

When the indicator is on working mode, activate the switch number 1 (in ON position) and check the valve number 1 is working. Then, disable the Switch 1 (in OFF position) and try with the Switch number 2. Repeat the test for all the valves.

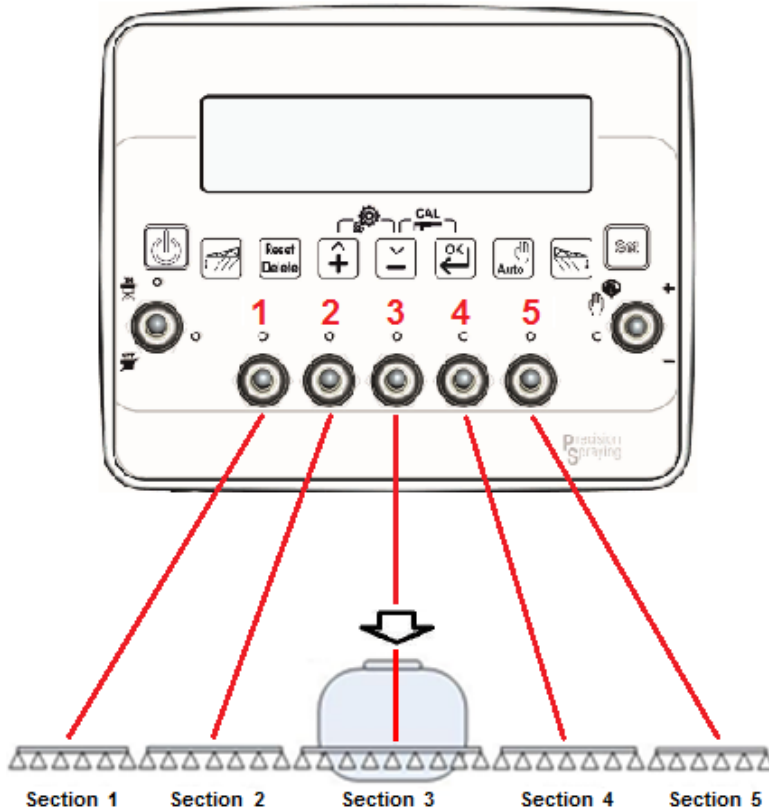

Picture 25 - Use of 5 sections

15

If all the connected valves are working, enter again in configuration menu and set the valve number at 4.

**Valves number
X**

ENGLISH

16 At this point the indicator is working with only 4 connectors as indicated on picture:

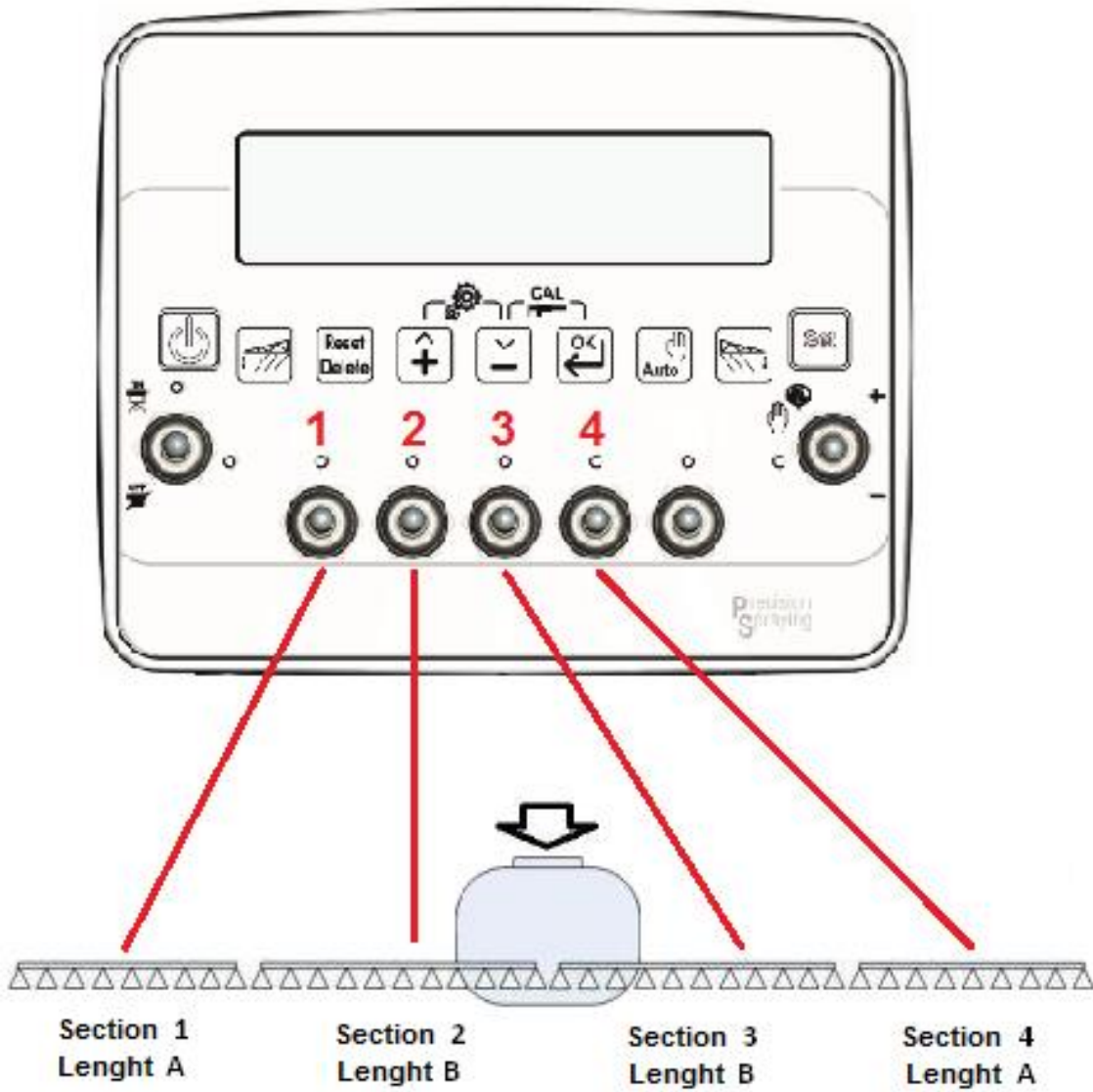

Picture 26 – Use of 4 sections

18.2 EXAMPLE OF GeoSystem 240 5W CS INSTALLATION ON SPRAYER SYSTEM WITH 3 SECTIONS

1 Make sure the system is exactly connected as on picture 5 at page 9.

2 In this step it is not important the sensor connection but the valve cable connection and the GeoSystem 240 driver box output connection.

3 Make sure all the switches are in OFF position so turn on the indicator by



pressing the key.

4 The first message "GEOLine GeoSystem 240" will appear on the display.

**GEOLine
GeoSystem 240**

5 It shows the Firmware revision and the system name.



**Rev. 1.0.4
Crop Sprayer**



6 It appears the message "please wait".

Please Wait

7 It appears the working values.

**A125 (150) 1/ha
3 0.0 km/h**

8 Press simultaneously the  and  keys to enter into the configuration menu.

9 Scroll up and down the entries of the menu using the  and  keys to arrive at the parameter "number of valves".

**General config.
Valves number**

10 Press the  key to enter into the configuration.



Go to the next step to verify the operation of the valves otherwise skip to step number 15.

11

Set the number 5 and press the



**Valves number
X**

12

It appears a new message “ General configuration Number of valves”.

**General config.
Valves number**

13

Press the



key to exit and to launch again the indicator.

14

When the indicator is on working mode, activate the switch number 1 (in ON position) and check the valve number 1 is working. Then, disable the Switch 1 (in OFF position) and try with the Switch number 2. Repeat the test for all the valves.

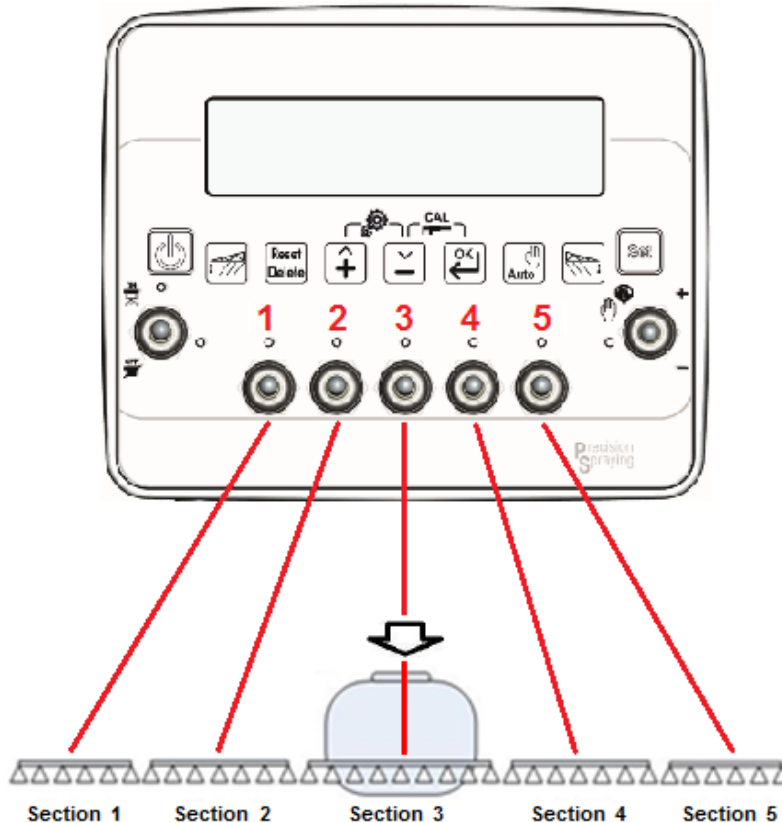

Picture 27 - Use of 5 sections

15

If all the connected valves are working, enter again in configuration menu and set the valve number at 3.

**Valves number
3**

16 At this point the indicator is working with only 3 connectors as indicated on picture:

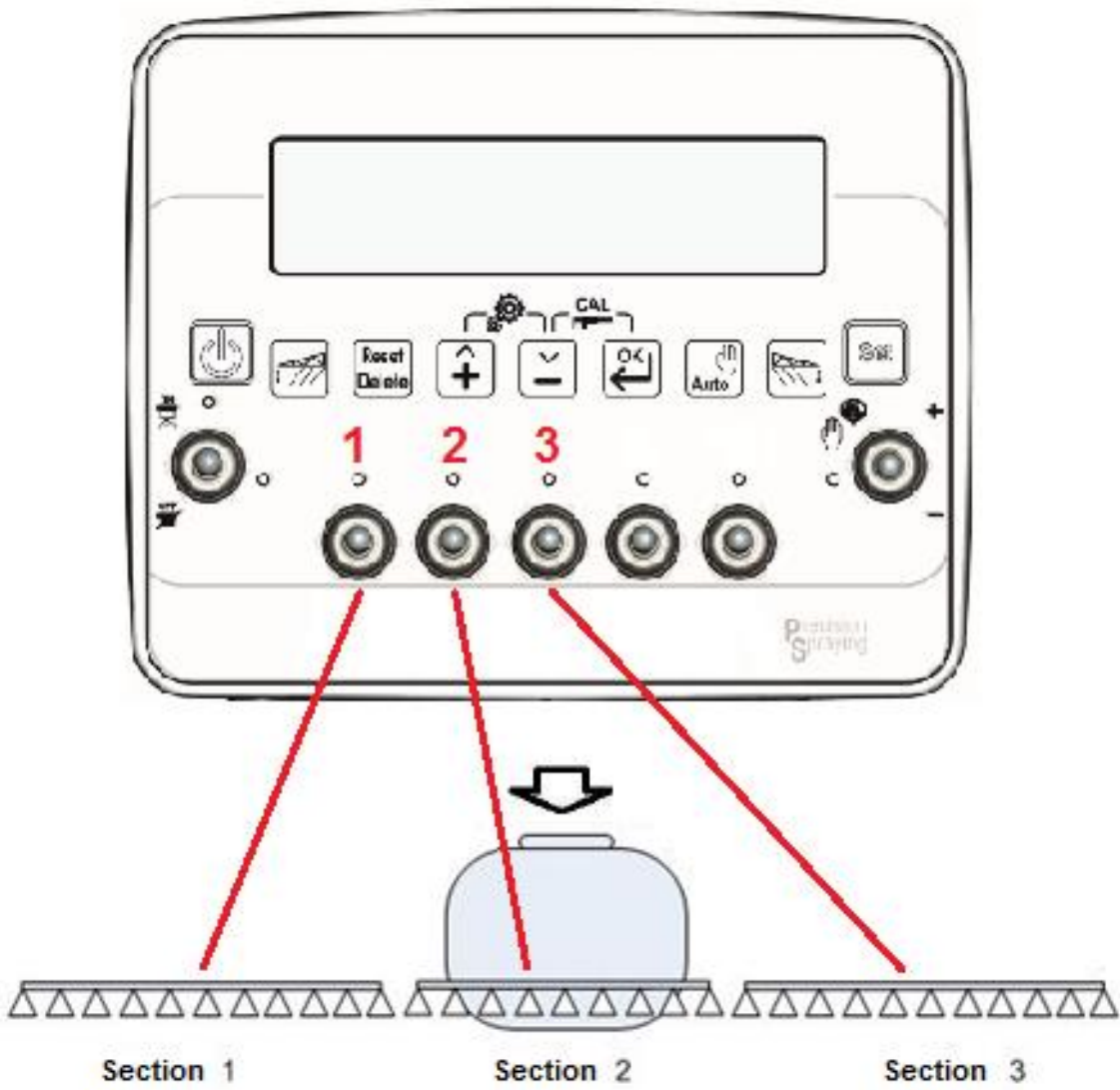

Picture 28 - Use of 3 sections

19 OTHER CONFIGURATIONS

ORCHARD SPRAYER (OS)

19.1 GeoSystem 240 4OS INSTALLATION ON SPRAYER SYSTEM WITH 2 SECTIONS

1 Make sure the system is exactly connected as on picture 8 at page 10.

2 In this step it is not important the sensor connection but the valve cable connection and the GeoSystem 240 driver box output connection.

3 Make sure all the switches are in OFF position so turn on the indicator by



pressing the key.

4 It appears the message "GEOLine GeoSystem 240" on the display.

**GEOLine
GeoSystem 240**

5 It shows the Firmware revision and the system name: Orchard Sprayer.

**Rev. 1.0.4
Crop Sprayer**

6 It appears the message "please wait"

Please Wait

7 It appears the working values.

**A125 (150) 1/ha
3 0.0 km/h**

8 Press simultaneously the



and keys to enter into the configuration menu.

9 Scroll up and down the entries of the



menu using the keys to arrive at the parameter "number of valves"

**General config.
Valves number**

20 DICHIARAZIONE DI CONFORMITA' UE EU DECLARATION OF CONFORMITY EU KONFORMITÄTSERKLÄRUNG DÉCLARATION UE DE CONFORMITÉ DECLARACION UE DE CONFORMIDAD EU ДЕКЛАРАЦИЯ О СООТВЕТСТВИИ

Nr 12/16

- IT** Il sottoscritto, designato a legale rappresentante della GEOLine Electronic s.r.l. , via Mondadori 15, Poggio Rusco (MN) - Italy, dichiara che i prodotti sottoelencati:
- EN** The undersigned, an authorised officer of GEOLine Electronic s.r.l. , via Mondadori 15, Poggio Rusco (MN) - Italy, hereby declares that the products listed hereunder:
- D** Der Unterzeichner, rechtlicher Vertreter der GEOLine Electronic s.r.l. , via Mondadori 15, Poggio Rusco (MN) – Italy, erklärt, daß die nachstehend beschriebenen Produkte:
- FR** Je soussigné, représentant légal désigné de GEOLine Electronic s.r.l. , via Mondadori 15, Poggio Rusco (MN) - Italy, déclare que les produits énumérés ci-après:
- ES** El suscrito, nombrado representante legal de la GEOLine Electronic s.r.l. , via Mondadori 15, Poggio Rusco (MN) - Italy, declara que los productos indicatos a continuación:
- RU** Нижеподписавшийся, являющийся законным представителем компании GEOLine Electronic s.r.l., расположенной по адресу via Mondadori 15, Poggio Rusco (MN) – Italy, заявляет, что продукция ниже

GeoSystem 240

- IT** Sono conformi a quanto prescritto dalle seguenti direttive:
- EN** Are in compliance with the following directives:
- D** Mit den Vorschriften konform sind, die in den folgenden Richtlinien:
- FR** Sont conformes aux prescriptions des directives suivantes:
- ES** Respetan las prescripciones contenidas en las siguientes directivas:
- RU** Соответствует требованиям следующих директив:

2014/30/UE

- IT** E dalle seguenti norme:
- EN** And with the following standards:
- D** Und Normen stehen:
- FR** Et aux normes ci-apres:
- ES** Y en las siguientes normas:
- RU** И следующих стандартов:

EN ISO 14982 Agricultural and forestry machinery -- Electromagnetic compatibility -- Test methods and acceptance criteria

- IT** E, in applicazione a quanto previsto dalle direttive citate, sono stati dotati di marcatura CE ed é stato predisposto un adeguato fascicolo tecnico presso la ns. sede.
- EN** And, pursuant of the above-mentioned directives, the CE mark has been applied. Furthermore, adequate technical file has been prepared and is available from our offices.
- D** Und daß sie in Übereinstimmung mit den Vorschriften der obengenannten Richtlinien mit dem CE-Zeichen versehen sind und daß dafür ein angemessenes technisches Heft erstellt wurde, das bei uns in der Firma zur Verfügung steht.
- FR** En application des directives citées, ils portent la marque CE et un dossier technique est déposé auprès de notre siège.
- ES** Y, conforme con lo previsto en las citadas directivas, han recibido la marca CE. Existe asimismo un específico prospecto técnico relativo disponible en nuestra sede.
- RU** И, в исполнении данных директив, был нанесен знак CE и соответствующее техническое досье было заведено в нашем офисе.

Poggio Rusco, 19/04/2016

Andrea GHIRALDI



21 **GUARANTEE**

The supplier guarantees, for 24 months from the delivery date, the good quality of materials used, the excellent construction and the steady functioning of the instrument they have manufactured and that bears the trademark or the production serial number. During the guarantee period the supplier undertakes to repair or replace, free supplier's head office, faulty parts due to poor materials or faulty construction, provided that such parts are delivered free port supplier's head office.

Shortcomings and defects due to incorrect use of instruments, inadequate maintenance, changes carried out without the supplier's approval, normal wear are not included in this guarantee.

Liability and compensations by the supplier due to direct or indirect damages to persons, objects or production, even as a consequence of faulty functioning of the supplied instruments or of material or construction defects, are not included in this guarantee.

NOTES:

GEOline electronic reserve itself the right to modify the contents of this manual caused by hardware and software implementations in order to a constant improvement of the product and so a better service to the user.

22 ISO TABLE (CS/OS)

NOZZLE [l/min]					
bar	2	2.5	3	3.5	4
ISO-01	0.32	0.36	0.39	0.42	0.45
ISO-015	0.48	0.54	0.59	0.64	0.68
ISO-02	0.65	0.72	0.79	0.85	0.91
ISO-025	0.82	0.90	1.00	1.07	1.15
ISO-03	0.96	1.08	1.18	1.27	1.36
ISO-04	1.29	1.44	1.58	1.71	1.82
ISO-05	1.61	1.80	1.97	2.13	2.27
ISO-06	1.94	2.16	2.37	2.56	2.74
ISO-08	2.58	2.88	3.16	3.41	3.65
ISO-10	3.23	3.59	3.95	4.26	4.56
ISO-15	4.83	5.33	5.92	6.38	6.84
ISO-20	6.44	7.17	7.89	8.50	9.11

Table 9 - ISO table

23 ATR TABLE (OS)

Nozzle type [l/min]					
bar	3	9	15	20	25
ATR-White	0.22	0.38	0.45	0.52	0.58
ATR-Lilac	0.28	0.48	0.61	0.70	0.77
ATR-Brown	0.38	0.64	0.81	0.93	1.04
ATR-Yellow	0.57	0.97	1.25	1.44	1.61
ATR-Orange	0.77	1.32	1.69	1.94	2.16
ATR-Red	1.08	1.83	2.33	2.67	2.97
ATR-Grey	1.18	1.98	2.51	2.88	3.20
ATR-Green	1.40	2.35	2.99	3.42	3.80
ATR-Black	1.57	2.64	3.36	3.85	4.28
ATR-Blue	1.92	3.24	4.12	4.72	5.25

Table 10 - ATR table

24 MGA TABLE (OS)

Nozzle type [l/min]					
bar	4.83	6.89	10.34	13.79	20.68
MGA-White	0.25	0.29	0.34	0.40	0.50
MGA-Golden	0.33	0.39	0.46	0.56	0.63
MGA-Orange	0.50	0.59	0.68	0.82	0.88
MGA-Green	0.75	0.90	1.05	1.25	1.53
MGA-Yellow	1.00	1.20	1.42	1.65	2.03
MGA-Lilac	1.25	1.50	1.81	2.07	2.51
MGA-Blue	1.50	1.80	2.20	2.50	3.00
MGA-Red	2.10	2.55	3.10	3.50	4.30

Table 11 - MGA table

“QUICK REFERENCE” GeoSystem 240

TREATMENT PREPARATION

1 To start the data recording of a new treatment, select a parameter of any working cycle, except the “level tank” parameter.

2 The system stores the treatment data in a tail of 20 elements.

3

Press for 5 seconds the  key to save the last stored data in the tail and to reset all the counters, prearranging the data recording of a new treatment you are going to do.

N.B: if the level sensor is not present, the pressure of the key will reset all the working data, except for the tank level which is reload to a pre-set value in configuration phase.

**Press for 5 sec.
to reset treat.**

USE

1 Automatic functioning of the system: GeoSystem 240 shows and records the speed, flow, travelled distance, treated area, amount of sprayed liquid values and it operates in a active way on the propositional valve. Moreover, it constantly maintains the dosage value at the variation of the vehicle speed and of the number of the active section valves.

**A 125 (150) 1/ha
▶3 0.0 km/h
"13.2 @ ± * A ↑ 208"
"5.8 ▶ 2 ↓ 12.05"**

2

Press the  key to activate the automatic functioning until letter A appears on display and then, activate the wanted section valves.

3

Press the  key to select the working values, if necessary.

4 Open the general valve and power up the tractor.

5

Place the switch  upwards to increase the amount of sprayed liquid, downwards to decrease it.

TANK REPLENISHMENT

1 If the treatment requires more chemical substance than how the vehicle tank can contains, the operator has the possibility to supply the tank with liquid and to eventually modify the insert quantity.

2 If the level sensor is not present, you have to manually set the tank level data.

In this case select the “level tank” data and, only in this case, press the



key to modify the data which is reloaded at the pre-set value in configuration phase.



TREATMENT VISUALISATION

1

Press for 3 seconds the  key to enter into the menu that allows to visualize the tail of the last 20 treatments.

**Press for 3 sec.
for totalizer**

2

Using the  and  key, it is possible to scroll up and down the treatment list. Press



to enter into the one of them.

DISPLAY CROP SPRAYER (CS) 2 / 4 VALUES

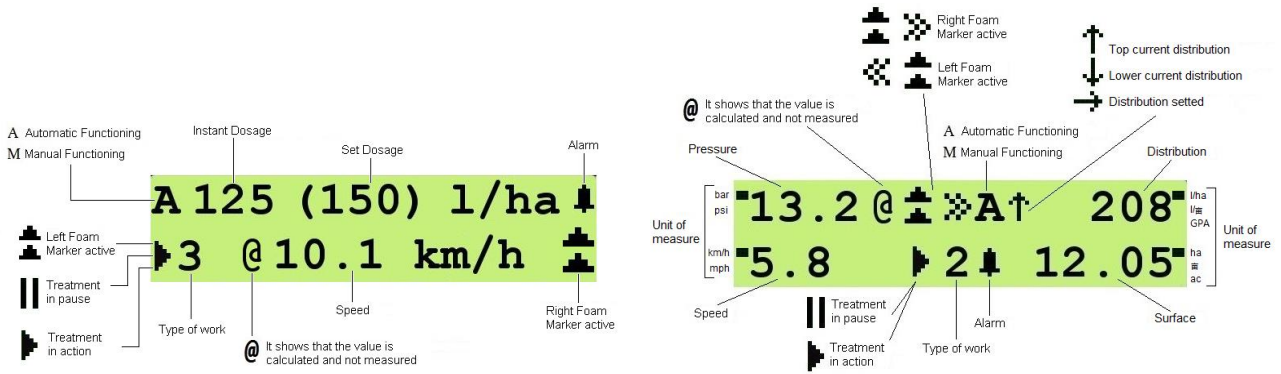

DISPLAY ORCHARD SPRAYER (OS)

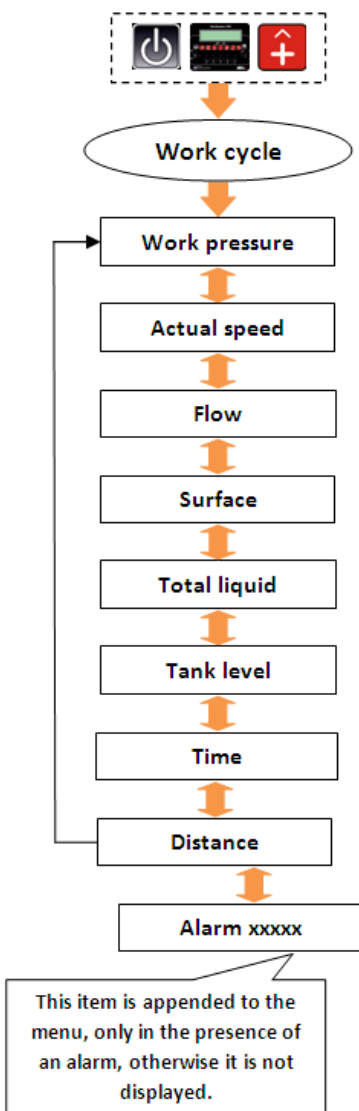
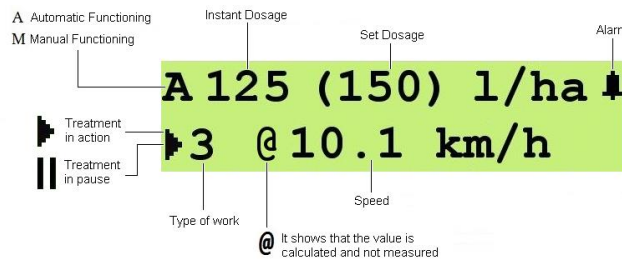







ALARMS

At the activation of one alarm you will hear a sound from the buzzer.

Press **Reset Delete** to disable it.

The active alarm state is highlighted by the sign  on the right of the first line of the display.

1. Flow regulation alarm	Alarm  flow regulation
2. Tank empty alarm	Alarm  tank empty
3. Minimum flow alarm	Alarm  minimum flow
4. Maximum flow alarm	Alarm  maximum flow
5. Low battery alarm	Alarm:  LOW BATTERY!
6. Low pressure alarm	Alarm:  low pressure



CONTACTS

INFO & SALES

sales_dept@geoline.it

SUPPORT

support@geolineelectronic.com

QUALITY & CERTIFICATIONS

For **GEOLINE Electronic S.r.l.**, sustainability means integrating long term economic, environmental and social dimensions into the way we operate our business according to the:



ISO 9001:2008



ISO 14001:2004



GEOLINE Electronic S.r.l. uses PEFC paper for printing manuals and catalogues.

Geoline Electronic S.r.l.
via Mondadori, 15
46025 Poggio Rusco (MN) - Italy
tel +39 0386.52134
fax +39 0386.51523

sales_dept@geoline.it