

FARMSCAN | jackal^{v3.5} monitor and controller series

For Serial Numbers 7000-9999



FARM SCAN

3 SECTION SPRAY RATE CONTROLLER
SPEED & AREA METER
TACH (RPM) METER
BATCH METER
RATE (LIQUID OR DRY) MONITOR
PRESSURE MONITOR
TEMPERATURE MONITOR
SURVEILLANCE MONITOR
WHEEL SLIPPAGE MONITOR
COUNTER FUNCTION



JULY 2020

| | |
|---|----|
| GENERAL DESCRIPTION | 1 |
| INSTALLATION | 2 |
| CONNECTIONS | 3 |
| INSTALLING SENSORS | 9 |
| OVERVIEW | 13 |
| SPRAYER (WIZARD) – CONTROL VERSION & SPRAY | 16 |
| AREA & SPEED METER SETUP (WIZARD) | 21 |
| AREA & SPEED METER USING GPS SETUP (WIZARD) | 24 |
| TACHOMETER - RPM METER SETUP (WIZARD)..... | 25 |
| FLOW METER SETUP (WIZARD)..... | 27 |
| SLIPPAGE METER (WIZARD)..... | 30 |
| RATE MONITOR – LIQUID | 31 |
| RATE MONITOR – SOLID | 32 |
| BATCH METER (JACKAL CONTROL ONLY)..... | 34 |
| BIN LEVEL SENSOR..... | 36 |
| AIR/VOLT/DEPTH/%/TEMP PRESSURE SENSOR | 37 |
| TRIPS | 40 |
| ALARMS..... | 41 |
| INPUTS | 42 |
| GENERIC WIZARD..... | 43 |
| FRONT SCREEN | 43 |
| OTHER SETTINGS | 44 |
| OUTPUTS..... | 45 |
| GPS/SERIAL | 46 |
| ABOUT JACKAL..... | 46 |
| DIAGNOSTICS..... | 46 |
| FACTORY RESET | 46 |
| WRITE YOUR SETTINGS DOWN | |
| NOTES | |

GENERAL DESCRIPTION

Your new Farmscan Jackal Spray Controller or Monitor system is the result of extensive infield development and will give many years of dependable service. Software & hardware updates are provided by Smart Ag Systems Pty Ltd.

3 Section Spray Controller (Controller Unlock)

Once installed and calibrated, the system will automatically maintain the selected spray rate regardless of speed or pressure variations within the limits of the sprayer pump capacity and nozzle size.

This version of the Jackal is completely unlocked, un-restricted and has the full feature set of the Jackal-Monitor. NB: Inputs consist of 7x Pulse & 2x Varying Inputs. Simply add additional sensors to utilise the Jackal to its full potential.

Our onboard calibration wizard makes setup a breeze! It's simplified with the ability to enter either a factor (pulses per unit) or simply drive/run a set amount whilst the unit is counting the pulses and let the system calculate its own factor.

24 recordable trips allow the operator to track numerous jobs in a period of work and each input can be used to display information using imperial and metric units.

TECHNICAL SPECIFICATIONS

Specifications below are subject to change and are based on a fully unlocked Jackal.

| | |
|---|---|
| Power Requirements (12Vdc) | 10 – 18 VDC @ 250mA |
| Display | 128 x 64 Mono Graphic LCD |
| Operating Temperature | 0 to 50° c |
| Storage Temperature | -5 to 65° c |
| Dimensions | 135mm H x 100mm W x 30mm D |
| Sensor Inputs | 9 |
| Inputs 1-5 & 8-9 (Square Wave) | Up to 400 pulses per second (On/Off/Freq) |
| Inputs 6-7 | Analog Voltage 0 – 5V |
| GPS | RS232 TX/RX |
| Ground | 2 |
| Output PWM | 2 |
| Output +12v | 1 |
| Output | 4 |
| Output current rating | 4A/output |

DISCLAIMER

The warranty offered on this Farmscan product is limited to the repair or replacement of the faulty goods. No liability will be accepted for loss of profit or productivity. **WARRANTY IS VOID** if power and or sensors are not connected as described in this guide.

INSTALLATION

PARTS LIST

| REF | PART NUMBER | DESCRIPTION | QTY |
|--------------|----------------------|-----------------------------------|---------------|
| 1 | A-Jackal | Jackal Monitor | 1 |
| 2 | AH-407 | Mounting Bracket | 1 |
| 3 ^ | P-321 x1 P-322 x1 | 11 Way Input Plug Green & Grey | 1 each colour |
| 4 ^ | AC-105 | 5m Power Cable | 1 |
| 5 ^ | HM-506 | Screw Driver | 1 |
| Not Pictured | AM-200 | Warranty Card | 1 |
| Not Pictured | AM-Jackal | Manual | 1 |
| 6 * | AC-4501/T | Jackal Tractor Harness 5m | 1 |
| 7 * | AC-4501/S | Jackal Section Harness 5m | 1 |

^ Items NOT supplied when purchased as full spray control kit

* Items supplied if full control kit purchased

PARTS PICTORIAL



An additional AC-4501/EXT – 10m extensions is available for purchase to extend the Parts 6 & 7 over a longer implement.

MOUNTING & INSTALLATION

The Jackal Monitor & Spray Controller is provided with a suction window mount. An optional RAM style is also available for purchase at an additional cost. Farmscan Part No: AH-407-RAM

Slide mount onto unit and push sideways to lock into place. Make sure you hear a click of the mount locking into place.

Place in a convenient position on the windscreen and using the toggle lever pictured above (Item 2), push all the way to the bottom until lever locks into position.

Note: Monitor should be mounted in a clearly visible position in the cab for the operator, but not in a position where it is subject to intense heat or moisture.

The connector on the rear of the Jackal Controller has the following connection points available for use

POWER CONNECTION

Power connection must come direct from the battery terminals. **WARRANTY IS VOID** if power is not connected as described in this section.

The supplied harness comes pre-terminated; however, this information is important if required in the future.

GND : Black or Red with Black Stripe
+ve 12v : Red

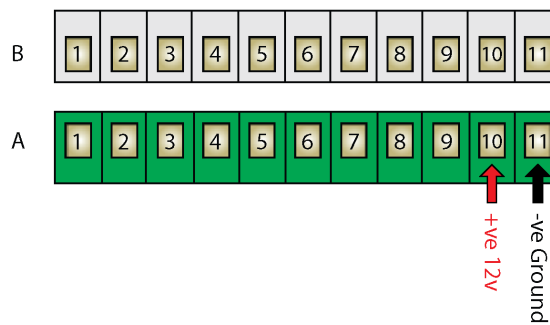

1. Connect power cable supplied **DIRECTLY TO BATTERY**
2. Ring terminals are used for battery connection and the bare end used to connect to the rear Jackal. (Refer above image for power connection)
3. Connect Ground to BATT -VE, **Terminal B11** using the **RED** with **BLACK** stripe wire
4. Connect **+12** Volts (+battery terminal) to BATT +VE, **Terminal B10** using the **RED** wire
5. Ensure that the battery connection to the Jackal is **+12 Volts**

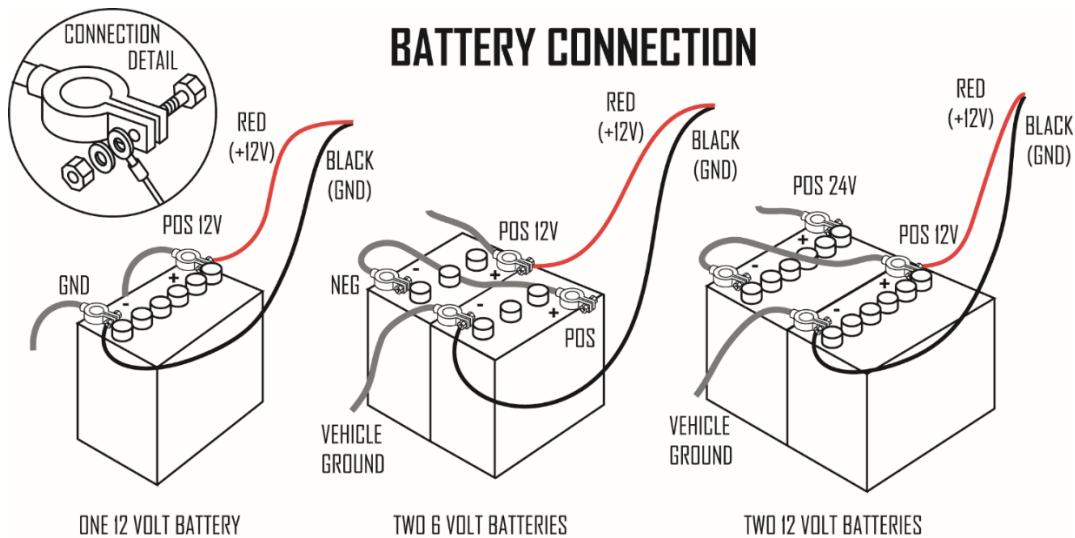

Connecting 24V to the Jackal will VOID WARRANTY



**Disconnect the terminal plugs
from the Jackal if **ARC
WELDING** on machinery**

REAR CONNECTIONS (MONITOR & CONTROL VERSION)

The connector on the rear of the Jackal Monitor & Controller has the following points available for use when the supplied Tractor & Section/Implement harness is not used.

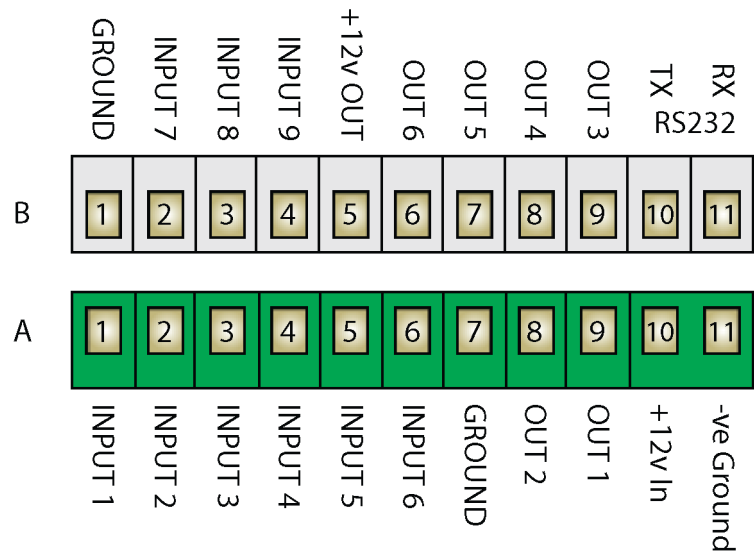

| A | BOTTOM ROW (GREEN PLUG) | B | TOP ROW (GREY PLUG) |
|-----|---|-----|---|
| A1 | INPUT 1 Prox / Reed / High-Low / On-Off / Alarm | B1 | GROUND Earth / 0v |
| A2 | INPUT 2 Prox / Reed / High-Low / On-Off / Alarm | B2 | INPUT 7 Varying Voltage Sensor |
| A3 | INPUT 3 Prox / Reed / High-Low / On-Off / Alarm | B3 | INPUT 8 Prox / Reed / High-Low / On-Off / Alarm |
| A4 | INPUT 4 Prox / Reed / High-Low / On-Off / Alarm | B4 | INPUT 9 Prox / Reed / High-Low / On-Off / Alarm |
| A5 | INPUT 5 Prox / Reed / High-Low / On-Off / Alarm | B5 | +12v OUT Supply Out / Sensor Power |
| A6 | INPUT 6 Varying Voltage Sensor | B6 | OUT 6 Dump |
| A7 | GROUND Earth / 0v | B7 | OUT 5 Section 3 |
| A8 | OUT 2 GND/+12v/Run/Hold/Alarm/Freq/Batch | B8 | OUT 4 Section 2 |
| A9 | OUT 1 GND/+12v/Run/Hold/Alarm/Freq/Batch | B9 | OUT 3 Section 1 |
| A10 | +12v In +12v Battery | B10 | RS232 TX From GPS |
| A11 | -Ve In Ground / GND Battery | B11 | RS232 RX From GPS |

Need an extra Prox Input?
Consider swapping your wheel sensor input for out T-135 GPS Speed sensor

- B5 supplies 12v out to sensors when the Jackal is turned on
- Free prox INPUTS maybe be used as the remote/run hold function
 - Excludes Varying Voltage Inputs

REAR CONNECTIONS (CONTROL VERSION & SPRAY)

The Jackal Spray Controller harness comes pre-terminated for ease of install and convenience.

The following table outlines the pre-termination of this cable.

| A | BOTTOM ROW (GREEN PLUG) | B | TOP ROW (GREY PLUG) |
|-----|-----------------------------|-----|--------------------------------|
| A1 | INPUT 1 / NOT USED | B1 | GROUND / GPS PIN 5 |
| A2 | INPUT 2 / FLOW SENSOR | B2 | INPUT 7 / NOT USED |
| A3 | INPUT 3 / TANK LEVEL SENSOR | B3 | INPUT 8 / NOT USED |
| A4 | INPUT 4 / WHEEL SENSOR | B4 | INPUT 9 / NOT USED |
| A5 | INPUT 5 / NOT USED | B5 | +12v OUT / COMMON SENSOR POWER |
| A6 | INPUT 6 / PRESSURE SENSOR | B6 | OUT 6 / DUMP VALVE |
| A7 | COMMON SENSOR GROUND | B7 | OUT 5 / SECTION 3 |
| A8 | OUT 2 / MASTER MOTOR - | B8 | OUT 4 / SECTION 2 |
| A9 | OUT 1 / MASTER MOTOR + | B9 | OUT 3 / SECTION 1 |
| A10 | +12v IN / +12V BATTERY | B10 | RS232 TX |
| A11 | -Ve IN / BATTERY GROUND | B11 | RS232 RX |

Notes as below:

- The Jackal sprayer harness is wired to suit the Farmscan control valve bank (see below)
- The Jackal Harness comes pre-terminated with Packard plugs & Pins
 - Adapter cables maybe purchased or included with some kits (Page7)
- This cable can be modified for different valve bank assemblies.
- Please refer to your implement supplier or auto electrician to determine the current requirement and wiring if you are not using a Farmscan control valve bank.
- The Jackal controller should only be connected directly to 3-wire motorised valves.
- If you are connecting to a 2 Wire section valve (E.g., Arag or Hardi) you will require a 2-3 Wire Converter (Farmscan Part Number A-2091) These are available to order at an additional cost.

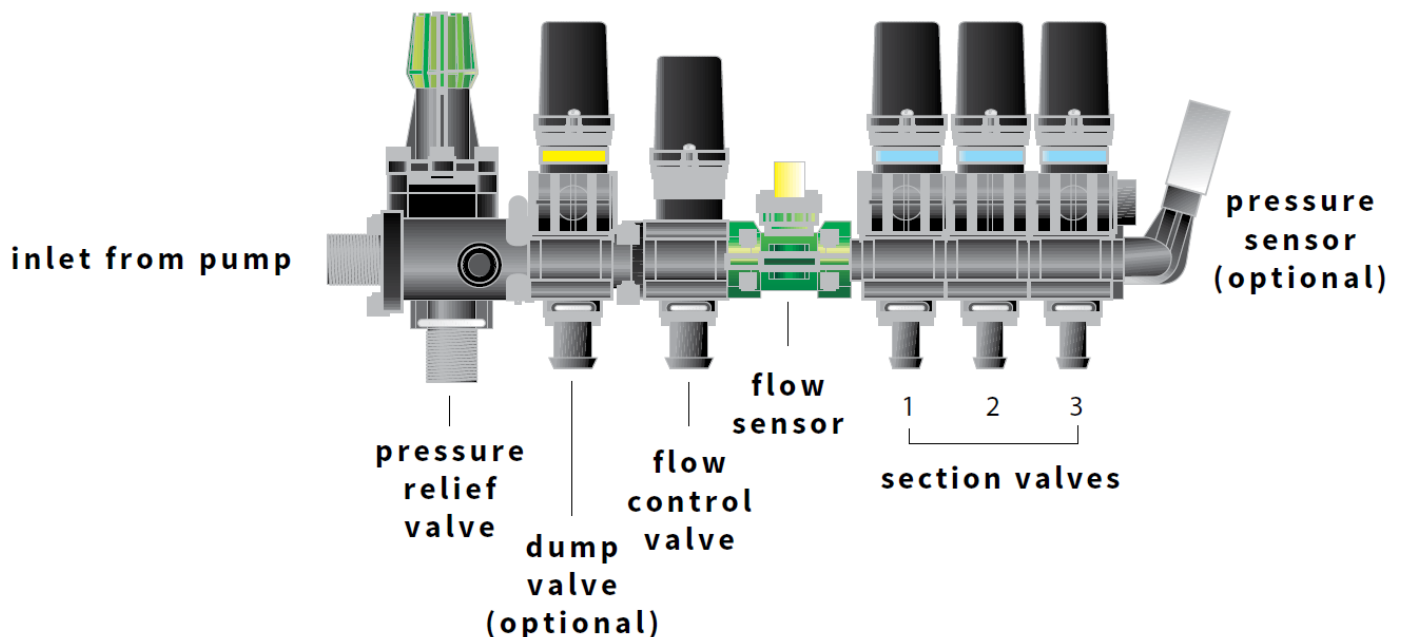

Example – Farmscan 3 Section Valve Bank
(Farmscan Part Number AA-AF-CONTROL/3 or /3-D with Dump)

TRACTOR HARNESS (CONTROL VERSION & SPRAY)

Overview of Tractor Harness as below

Connect to rear of Jackal

P2 - GREY

P1 - GREEN

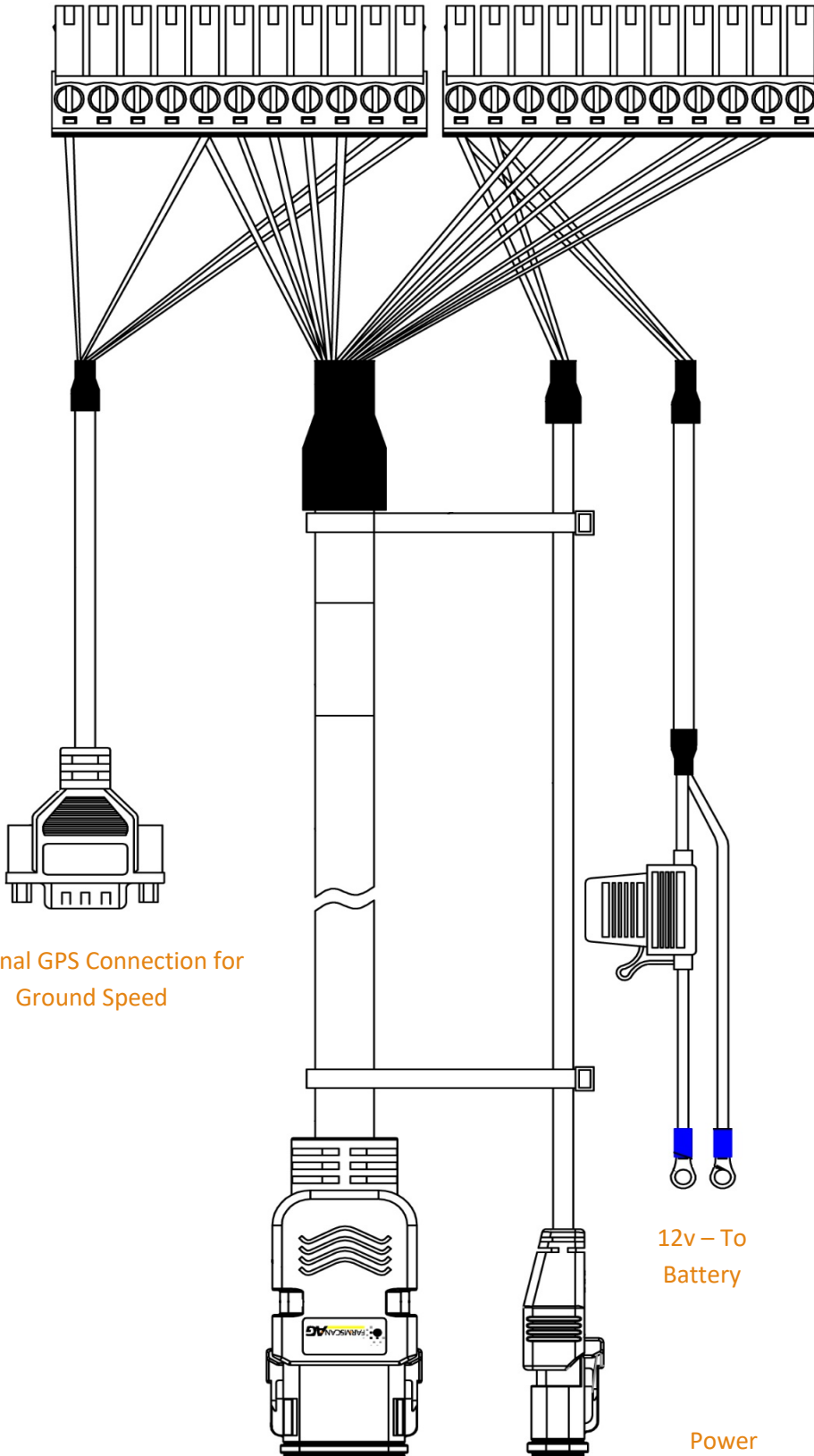

Jackal Tractor
Harness

Part #
AC-4501/T

Optional GPS Connection for
Ground Speed

12v - To
Battery

Sensor
Connector

Power
Connector to
Sensors

IMPLEMENT/SECTION HARNESS (CONTROL VERSION & SPRAY)

Overview of Implement/Section Harness as below

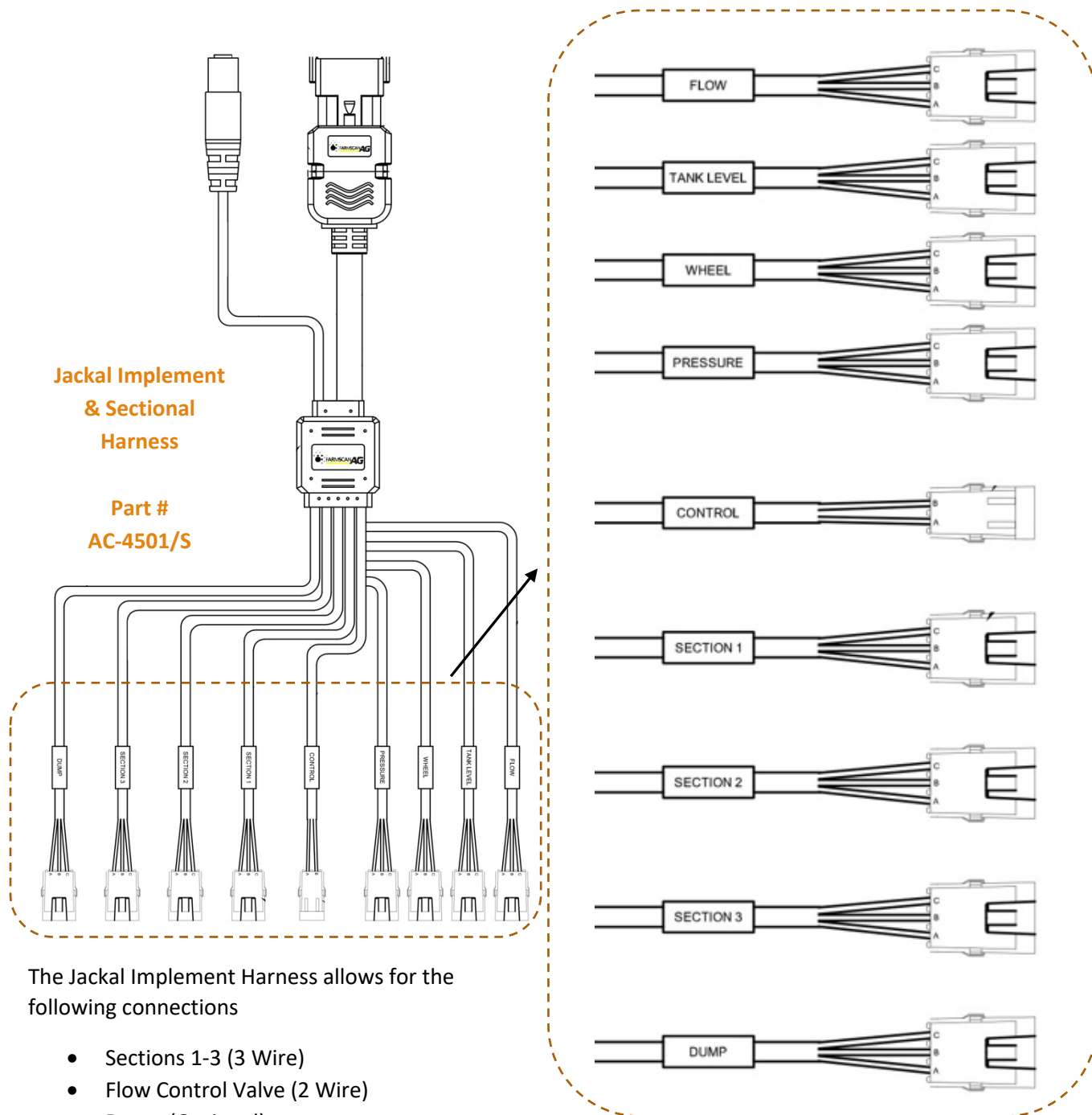

The Jackal Implement Harness allows for the following connections

- Sections 1-3 (3 Wire)
- Flow Control Valve (2 Wire)
- Dump (Optional)
- Pressure
- Wheel Input (Speed)
- Tank Level Sensor
- Flow Meter (3 Wire)

NB: The Jackal harness comes pre-terminated with Packard's. Kits purchased directly may include adapters as below.

Packard Adapters are as follows:

- AC-7722 – Packard to Flow Control
- AC-7721 – Packard to Section Valves



Connect to implement as required. Unused connectors and wires should be taped back to avoid weather corrosion or accidental shorting and damage.

NB: All Red Wires are +12v (live when Jackal is on) – DO NOT SHORT



SPRAY HARNESS OVERVIEW (CONTROL VERSION & SPRAY)

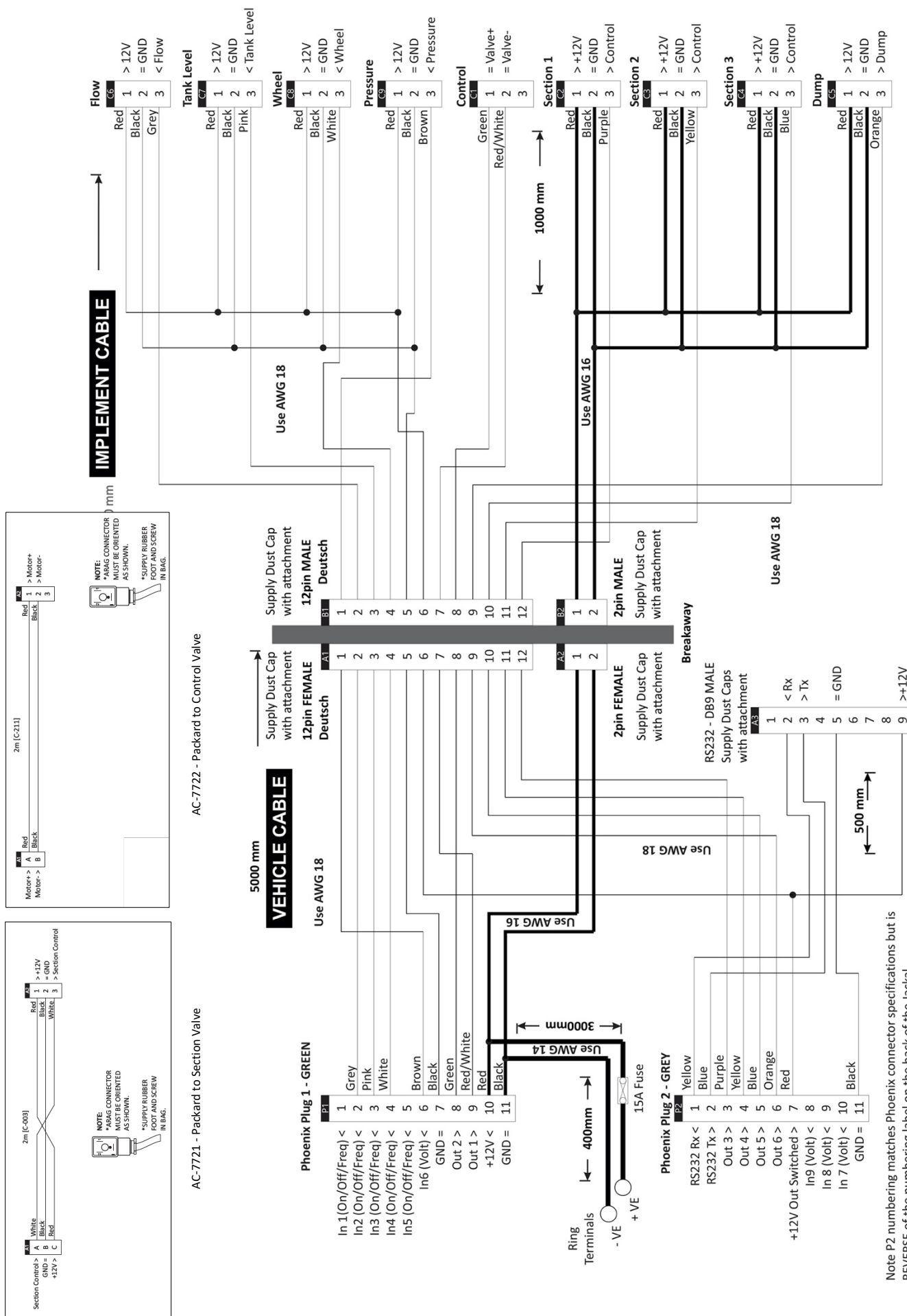

Note P2 numbering matches Phoenix connector specifications but is REVERSE of the numbering label on the back of the Jackal

INSTALLING SENSORS

The following examples will help to determine appropriate sensor input connections into the Jackal **IF** you choose to alter the pre-terminated cable to your specifications or have purchased the fully unlocked Jackal Control.

TWO WIRE “REED” – BLACK END SENSOR (OLD SENSORS) KIT # 1007P, 2009, 2076

These kits will all include a “reed” type sensor. The reed type sensor is a 2 wire sensor (normally black end) and only uses a ground/earth wire and a signal wire.

The diagram to the right shows which terminals to connect your sensors to.

Insert the black ground wire to either **(A7 or B1)** and the white/coloured signal wire into any **(A1-A5 or B3-B4)**

Use the wizard to setup the port and calibrate a sensor once installed.

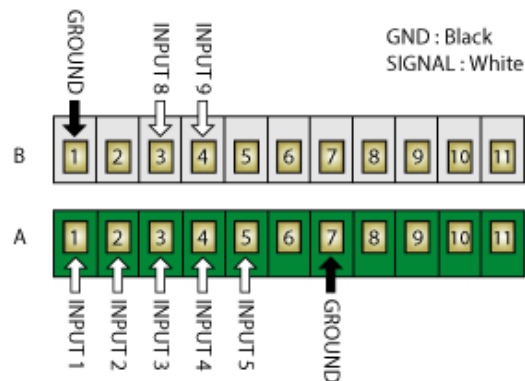

THREE WIRE – PROX SENSOR OR 3 WIRE FLOW METERS (NEW SENSORS)

KIT # AA-2011P, AA-123P, AA-125, AA-242, AA-230X, AA-232X, AA-231

These kits will all include a “square wave” type sensor. The sensor is 3 wires and uses a ground/earth wire, a signal wire and a 12v power wire.

These inputs are also used with 3 wire (square wave) flow meters.

The diagram to the right shows which terminals to connect your sensors to.

Insert the ground wire to either **(A7 or B1)** and the sensor wire into any **(A1-A5 or B3-B4)** and the power wire to **(B5)**

Use the wizard to setup the port and calibrate a sensor once installed.

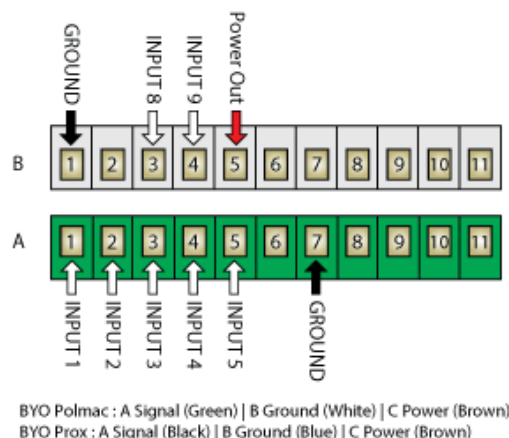

NB: A Proximity sensor can be used for wheel speed or RPM.

THREE WIRE “ANALOGUE/VOLTAGE” – PRESSURE SENSOR OR DEPTH SENSOR
KIT # AA-114, AA-119-H, AA-119-L, AA-430

These kits will all include an “analogue” type of sensor. The analogue sensor is 3 wire and uses a ground/earth wire, a signal wire and a 12v power wire.

Typical sensors would include Pressure & Depth.

The diagram to the right shows which terminals to connect your sensors to.

Insert the ground wire to either **(A7 or B1)** and the sensor wire into **(A6 or B2)** and the power wire to **(B5)**

Use the generic wizard to setup the port and calibrate a sensor once installed.

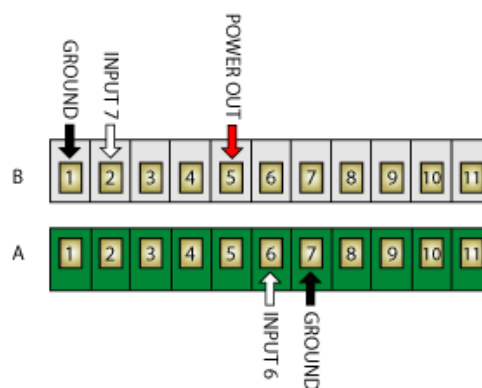

NB: The AA-430 (Depth Sensor) is powered by 5v – Please contact us to discuss powering options via the Outputs Menu

THREE WIRE “BIN/TANK LEVEL”
KIT # 2060, A-2220P, A-2221

These kits will all include an “on/off, high/low, empty/full” type of sensor. The analogue sensor is 3 wire and uses a ground/earth wire, a signal wire and a 12v power wire.

The diagram to the right shows which terminals to connect your sensors to.

Insert the ground wire to either **(A7 or B1)** and the sensor wire into any **(A1-A5 or B3-B4)** and the power wire to **(B5)**

Use the generic wizard to setup the port and calibrate a sensor once installed.

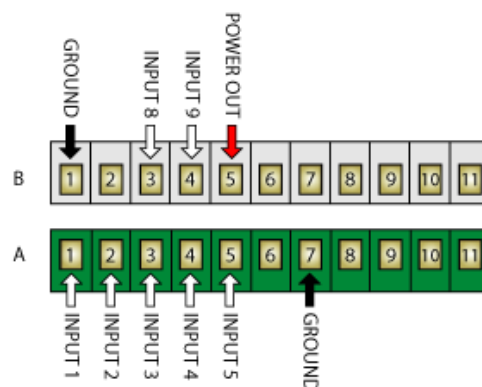

GPS
KIT #T-135

GPS units supplied from Farmscan are pre-programmed and ready to use with the Jackal Monitor.

The diagram to the right shows which terminals to connect your GPS to.

Insert the black or green wire to **(B1)** and the white or yellow wire into **(B11)** and the red wire into **(B5)**

Use the wizard to setup the port and calibrate once installed.

NB: If you BYO GPS please ensure: GGA, VTG, RMC, 5Hz and a baud rate over 19200kbps.

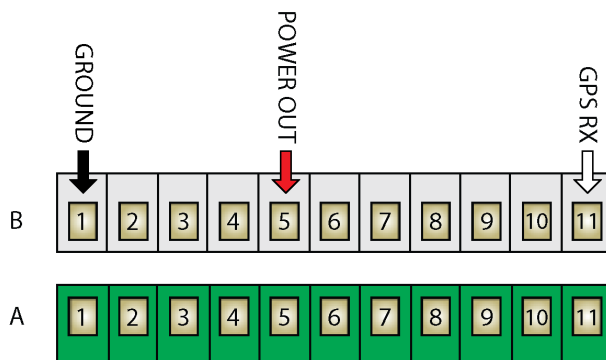

GND : Black
 SIGNAL : White
 POWER : Red

BATCH (SOLENOID)

KIT # 1501

The Batch function is designed to measure bulk water into a spray tank via either a bottom or top fill system. The minimum flow rate for effective operation is 75 L/min to a maximum of 750L/min using our standard 2" flow sensor.

Water may be pumped, or gravity fed through the flow sensor, which will give accurate readings providing no air enters the system. The Flow sensor can be installed on either the suction or pressure side of the water delivery system, and the readout will count up to display the total litres delivered.

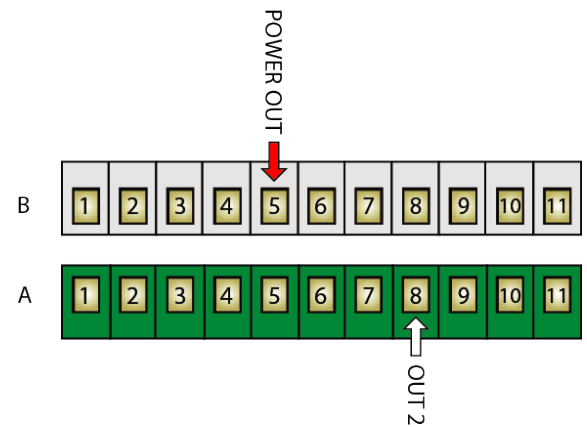

Alternatively, the TANK BATCHMETER may be automated by installing either the SOLENOID SHUTOFF option which will automatically stop the flow after the readout counts down to zero from a preset batch total.

When using the Jackal as a batch meter with liquid, please ensure the appropriate flow meter is setup as per the previous instructions.

Insert one wire to **(B5 POWER OUT)** and the other wire into **(A8 OUT 2)**

Use the wizard & instructions to setup the port and calibrate once installed.

If water quality is doubtful, water intake should be filtered via an 80-mesh filter before the flow sensor, to avoid foreign matter clogging / jamming the turbine. Chemicals may be introduced into the water stream without causing damage to the flow sensor, but some chemicals may damage or reduce the solenoid diaphragm life, particularly if undiluted.

REMOTE RUN/HOLD (ACTIVATE BY INPUT)

The Jackal can connect an external Run/Hold trigger (e.g. Remote Switch) & wire into any unused signal INPUT port **(A2-A6 & B3-B4)**

This allows the Jackal to be remotely placed on hold or run mode from an external source or switch without having to press the Run/Hold button on the Jackal itself. When the external Run/Hold is active on the mentioned inputs the Run/Hold button on the Jackal is then **disabled**.

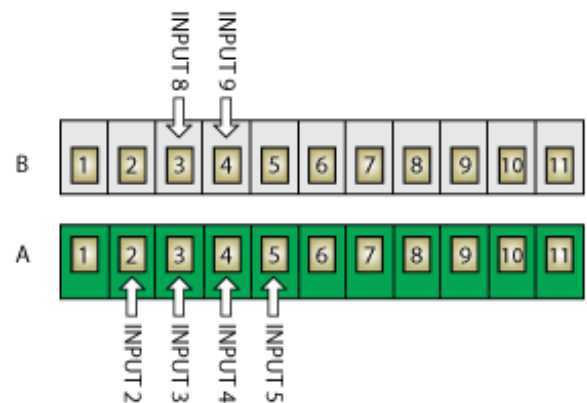

Insert the ground wire from your external switch to any of the unused ports as mentioned above.

NB: In some cases, you may have to use an automotive relay to provide the appropriate ground output.

NORMALLY ON

WHEN A CIRCUIT EXISTS BETWEEN THE SELECTED INPUT AND GROUND (GND), SELECTING NORMALLY ON WILL RESULT IN THE JACKAL GOING INTO HOLD MODE

NORMALLY OFF

SELECTING NORMALLY OFF WILL RESULT IN THE REVERSE I.E. THE JACKAL WILL BE IN RUN MODE UNTIL THE CIRCUIT IS BROKEN AFTER WHICH IT WILL GO INTO HOLD MODE.

Enable the remote run/hold via **OTHER SETTINGS** as further described on **PAGE 44**.

REMOTE RUN/HOLD (ACTIVATE BY OUTPUT)

The Jackal Monitor has the ability to Run/Hold an external device such as a remote clutch switch.

There are 6 outputs available on the Jackal. **(A8-A9 & B6-B9)**

This allows you to press the Run/Hold on the Jackal to enable an external operation.

NB: This function is used in conjunction through an automotive relay.

Example: Hella Automotive Relay (12v / 30A) – 4RA003510-08

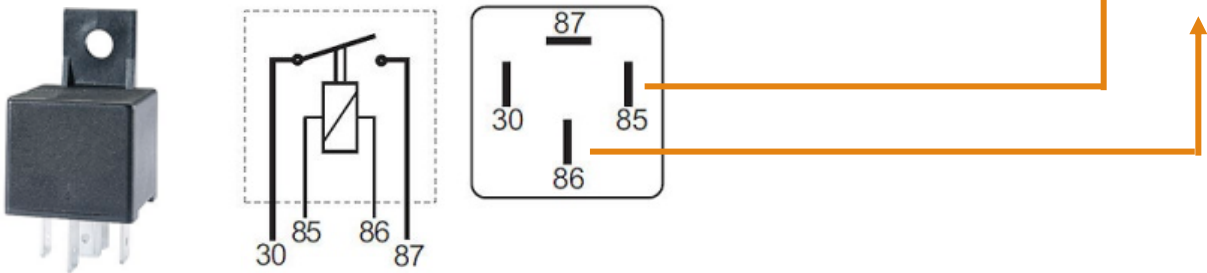

Pin 86 to A9 Out 1 (Jackal +12v Run/Hold Output)

Pin 85 to A7 (Ground)

Pin 30 to 12v in (Direct to Vehicle Battery)

Pin 87 to Positive Side of clutch switch *(Ensure negative/ground on other side of switch returns to battery)*

Enable the remote run/hold out by:



From the front screen press
SETUP



Highlight **OUTPUTS** and press
SELECT

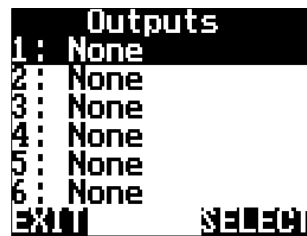

Highlight **1: NONE** and press
SELECT

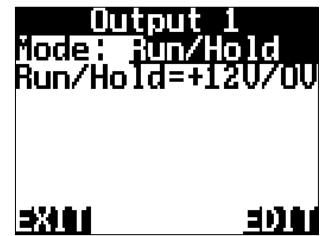

Press **EDIT** and change to
MODE: Run/Hold
Press **EXIT**

Run/Hold can be changed
from +12V/0V to 0V/+12V
by pressing **EDIT**

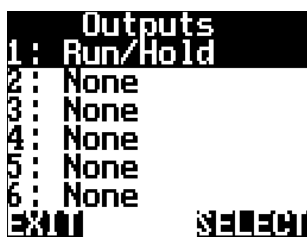

Press **EXIT** when done.

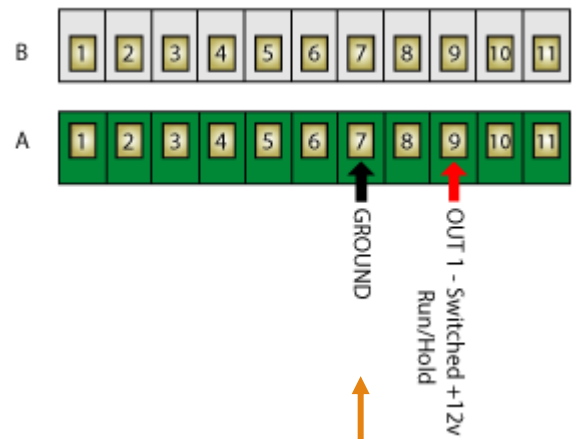

BUTTON FUNCTIONS

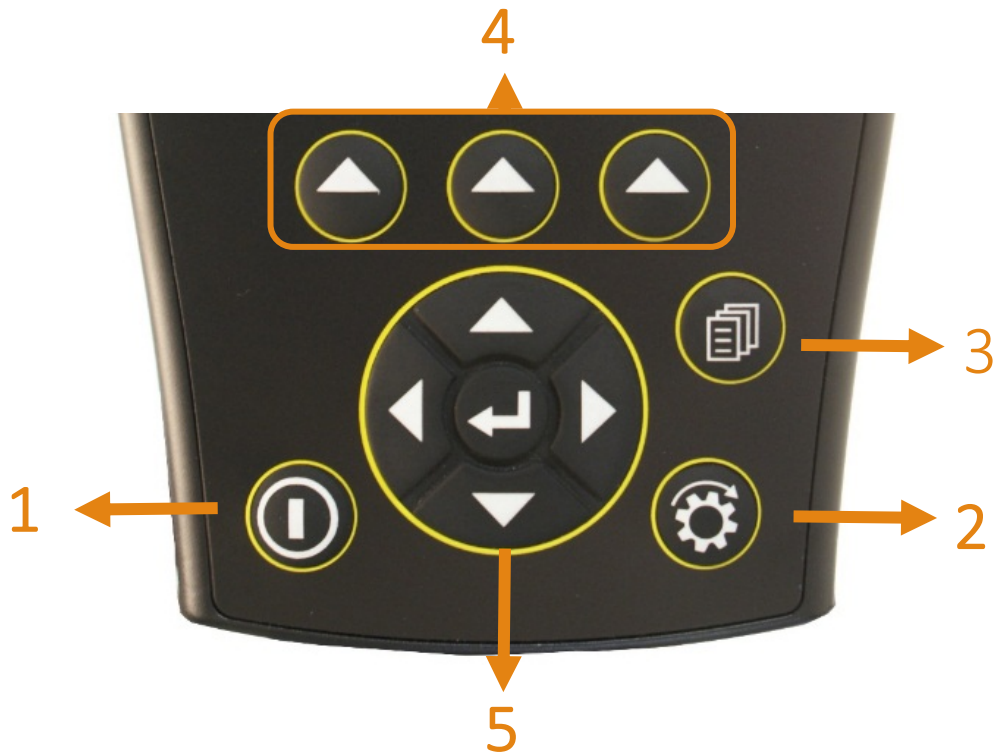

1. Power On/Off button

- a. Power is turned on by pressing the **ON/OFF** button for 1 second.
- b. Power is turned off by holding the **ON/OFF** button for 2 seconds.

2. Run/Hold button

- a. The **RUN/HOLD** button has a dual function.
 - a. Press **RUN/HOLD** once to place the 'MONITOR ON HOLD'.
 - b. Press **RUN/HOLD** again to resume operation.
- b. The **RUN/HOLD** state is indicated in the top left-hand corner of the screen. When the monitor is in RUN mode, the unit displays RUN to signify that the monitor is active.
- c. When the monitor is in **HOLD** mode the unit displays the word "**HOLD**" & "**BEEPS**" every 2 seconds

3. Page button

- a. The **PAGE** button is used to scroll through BATCH mode screens or Spray Control functions.

4. Select button (3 of)

- a. The Jackal has 3 buttons placed directly under the LCD. These buttons will change function in different menus.
- b. The function of the button is indicated at the bottom of the screen directly above the button.

5. Navigation button (Up, Down, Left, Right, Enter)

- a. The Round navigation (**NAV**) buttons are used to navigate **UP/DOWN/LEFT/RIGHT** in calibration screens as well as scrolling through the display lines on the main screen.
- b. **ENTER** is used to select the option highlighted onscreen.

SCREEN LAYOUT

The Jackal can display one, two or three lines of live information at any one time.

Using the middle **NAV/Enter** button allows you to toggle between the different display modes when multiple inputs are being used.



Example: 1 Line



Example: 2 Line

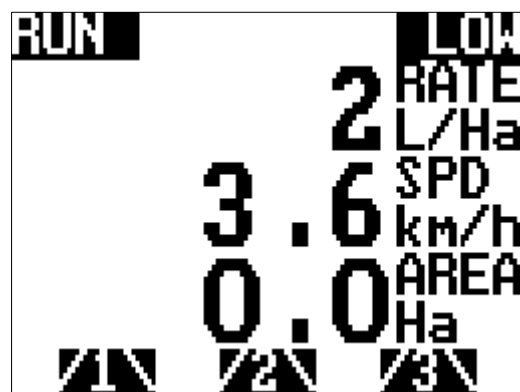

Example: 3 Line

The level of Jackal unlock will determine what options are viewable and available to be edited.



Use the NAV button down to reveal further menu information



- Wizard** Run a predefined wizard for setting up the Jackal Monitor as:
 - Sprayer (Automatic Mode) – *Control Version*
 - Area/Speed Wheel
 - Area/Speed GPS
 - Tachometer (Fast & Slow option available)
 - Flow Meter
 - Slippage Meter
 - Generic Wizard

- Inputs** Manually enable or edit ports in which sensors are connected to.

- Front Screen** Enable/define/order/edit/name the lines on the front screen.
Select the number of decimal places displayed and edit the alarms.

- Other Settings** Change speed input, implement & section widths, external run/hold alarm notification settings (beep & on hold), language options, speed simulation for diagnostics.

- Outputs** This menu is used to control the Jackal outputs. Refer to this manual and edit the outputs described ONLY to prevent damage to external sensors connected to the Jackal.

- GPS/Serial** When an external GPS is connected view and ensure the GPS is setup correctly. Setup baud rate and confirm GPS messages (NMEA messages RMC or GGA+VTG are required) Latitude, Longitude, heading, speed, date & time.

- About Jackal** Shows current version of Jackal software and unlock codes installed on the unit.

- Diagnostics** Shows current input voltage and input diagnostics on enabled ports.

- Factory Reset** Returns the Jackal to factory default.

SPRAYER (WIZARD) – CONTROL VERSION & SPRAY

The Jackal can be setup to control an application rate when using both a speed & flow input. It offers Fully Manual, or Manual with auto dump valve open when stopped & Full Rate Control when varying speed.

Rates and 3 sections can be controlled from the main screen

Sensors Required:

- Wheel Sensor/GPS for Speed & Area calculation
- Flow meter (any style) to display Litres

Available Connections: Refer to Installing Sensors from **PAGES 9-11.**

If purchased as a Spray Kit, the appropriate harness & connectors are supplied.

NB: The following setup uses information from multiple pages in this manual.

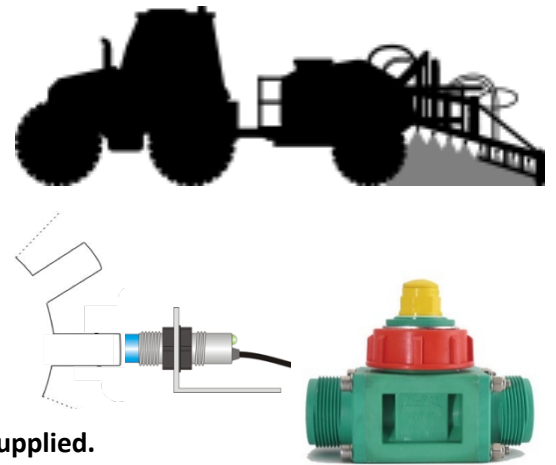

SETUP – AUTO MODE (WIZARD) – MOST COMMON



From the front screen press
SETUP



Highlight **WIZARD** and press
SELECT

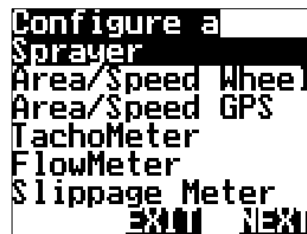

Highlight **Sprayer** and
Press **NEXT**



Select Spray Mode
Auto: Requires Speed & Flow Input. Auto rate adjust
Manual: Adjust the Flow Control Valve Manually

PAGE 18

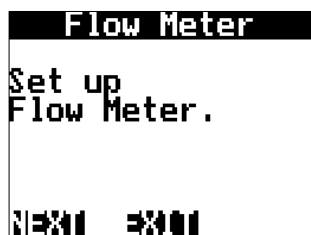

Press **NEXT** to setup your Flow Meter

NB: Please have your Pulse Per Litre (PPL) factor from your flow meter ready to enter.



Press the **DOWN** arrow to the Manual Ratio value of 500.00 & Press **EDIT** to change the unit of Pulse.



Using the **NAV** buttons enter the PPL factor as displayed on the flow meter tag.
Press **EXIT** when done.



Press **NEXT** to accept the new manual ratio (PPL)

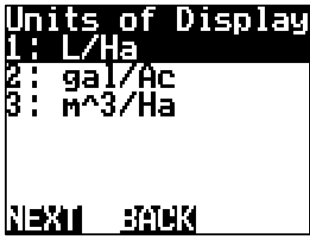

Using the NAV buttons select how you would like the UOD to be displayed on the front screen.
Press NEXT

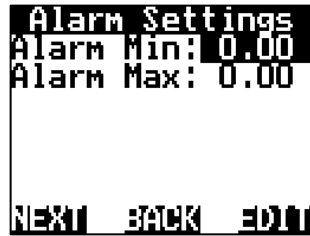

You have the option to set Alarm Min/Max points if required. Using the NAV buttons select and EDIT as required. Press NEXT

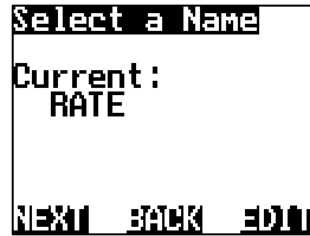

Change the input name if you desire, Press EDIT, or Press NEXT

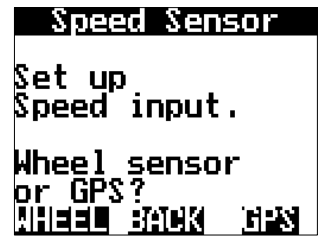

Select WHEEL or GPS to setup the speed input. This depends on the speed option you have purchased.
For Wheel:
Refer to Page 21 to 23
For GPS:
Refer to Page 24



Press EDIT and change the number of sections required to control.
Press NEXT

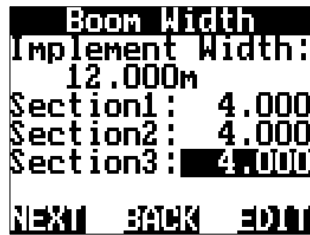

Using the NAV & EDIT keys, highlight and edit the section width values as required. The Section Widths will also Total and be displayed. Press NEXT

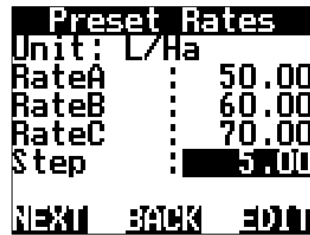

Using the NAV & EDIT keys, highlight and edit the "Quick set Rates" & Quick rate Step Value.
Press NEXT

The Jackal has the ability to have Preset Rates across the bottom of the screen.
Example 50l/ha, 60l/ha etc.

The Step rate allows you to easily up the rate by this amount quickly from the front screen.
Press NEXT

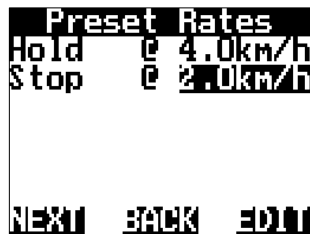

Using the NAV & EDIT keys, highlight and edit the HOLD & STOP values as described below
Press NEXT

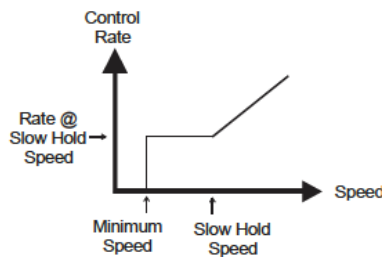

- The Slow Hold Speed function is used to avoid loss of spray coverage caused by loss of pressure when travelling too slow or when reducing the target rate below the recommended minimum for the nozzles.
- If the implement is travelling below this speed (but above the minimum speed) then flow control is regulated as if the implement were travelling at the Slow Hold Speed.
- NOTE: Slow Hold is an optional function that can be set to operate at a minimum speed equivalent to the minimum recommended pressure for a given target rate (speed-based).
- STOP: Will simply put the Jackal on hold at a set speed.



Change the input name if you desire, Press EDIT, Press NEXT

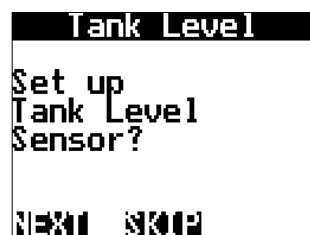

If you wish to setup a Tank Level Sensor please refer to **PAGE 36**. If not, Press SKIP



Press NEXT to finalise the Wizard and return to the front screen



THIS ENDS THE AUTO SET WIZARD SETUP FOR SPRAYER SETUP

SETUP – MANUAL MODE (WIZARD) – NOT SO COMMON

The Jackal can be setup to work in **MANUAL** mode in the event of no wheel speed or flow meter input, or combination of both. Manual mode simply allows adjustment of the flow control valve. In the event of a dump valve being installed, manual mode will close the dump valve & open all sections when the Run/Hold button is pressed.



Select **MANUAL**: To Adjust the Flow Control Valve Manually



Press **SKIP**



Press **SKIP**



Press **EDIT** and change the number of sections required to control. Press **NEXT**



Using the **NAV & EDIT** keys, highlight and edit the section width values as required. The Section Widths will also Total and be displayed. Press **NEXT**

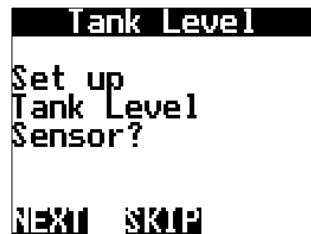

Press **SKIP**



Press **NEXT** to finalise the Wizard and return to the front screen



When you return to the **Front Screen** the Jackal needs to display a value.

The value of 1.0km/h is not relevant. It's simply used for the manual function



Press the Run/Hold button

You can now manually adjust your flow control valve by pressing the Rate + or Rate -

Simply drive to a set speed

Press the **PAGE**  button to display Rate+/- Flush

SPRAY CONTROL – HOW TO USE

Once the Sprayer Wizard has been run you are now ready to start spraying. Familiarise yourself with the Spray Controller layout as described below.

The Jackal Spray Controller Menu is laid out in 4 easy to use menus. These can be easily accessed by pressing the

PAGE  button

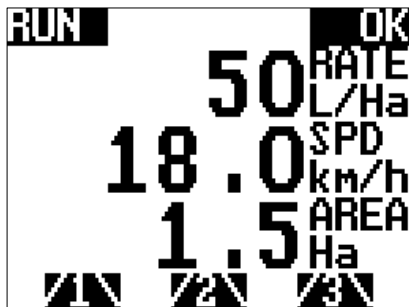

Default Section On/Off Control & Run Screen

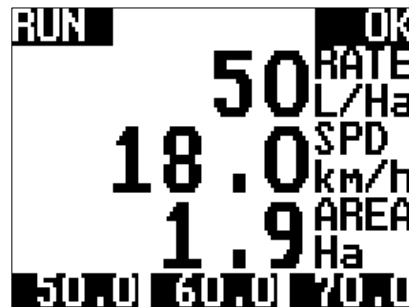

Pre-Set A/B/C Rate Screen

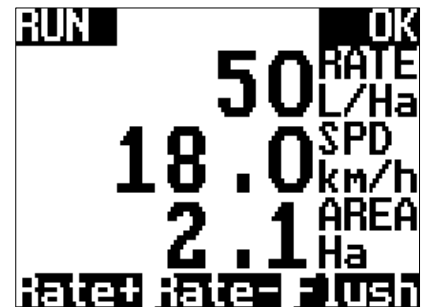

Step Rate Adjust & Flush Screen

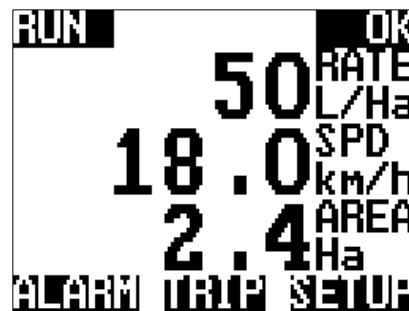

Alarm, Trip & Setup Layout

DEFAULT RUN & HOLD SCREEN

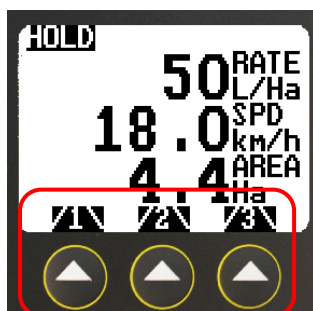

Sections can be individually turned On/OFF by pressing the soft keys underneath the sections numbers “/x\”

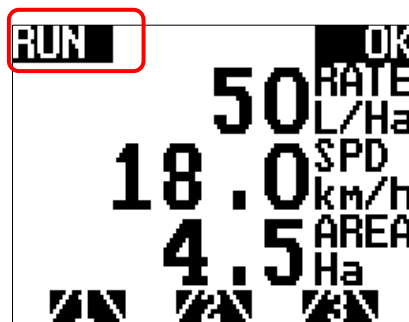

Pressing the Run/Hold button changes the Jackal from **HOLD** to **RUN**

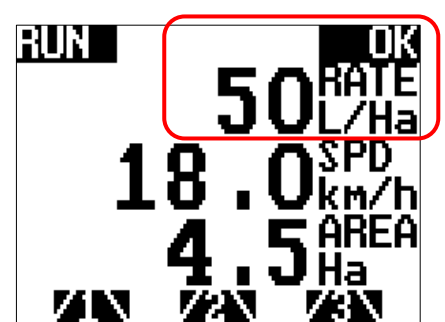

The LIVE rate in L/Ha is displayed and if the desired target is reach, OK will also be displayed

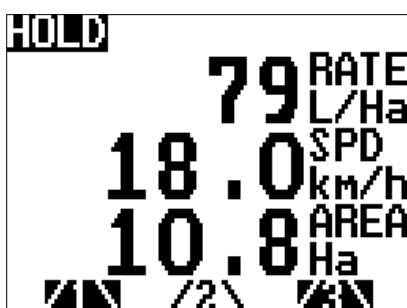

Example shows Section 2 as OFF

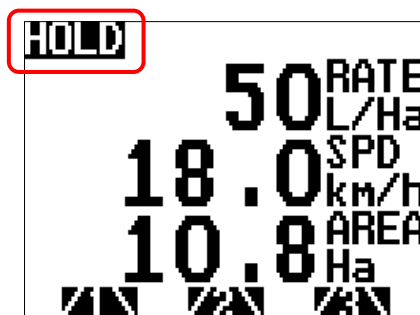

Example - HOLD

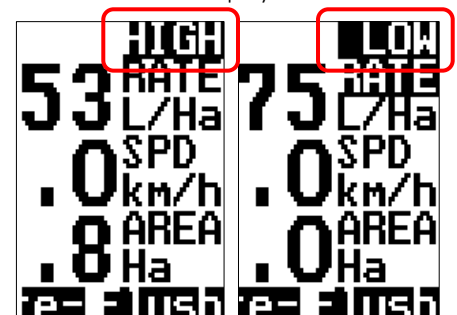

Both HIGH & LOW rate warnings are also displayed

PRESET RATES SCREEN



Quick Pre-set rates allows you to change rates on the go with ease. The Jackal will control up or down to the desired rate depending on vehicle speed.

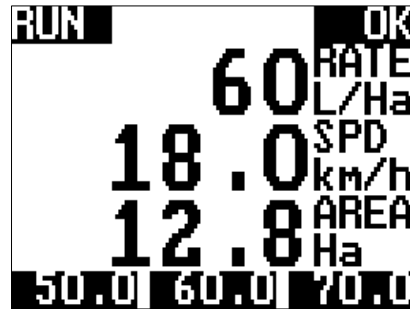

Pre-Set Rates can be changed via
SETUP > FRONT SCREEN > RATE
RateA/B/C/D

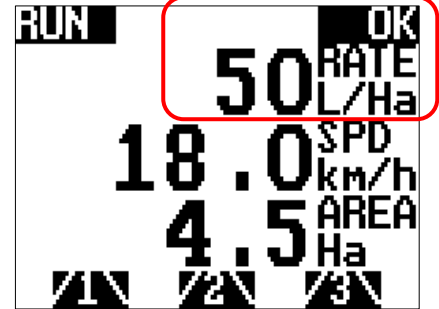

When changing rates, the Jackal will adjust the master control valve to allow more or less flow.

NB: If you believe the rate is not being maintained correctly when you speed up and slow down, it's possible the Flow Control Valve is opening back to front.

Please refer to the **OUTPUTS** on **PAGE 45** to swap the + & - Outputs

MANUAL RATE & STEP ADJUST DURING FLUSH

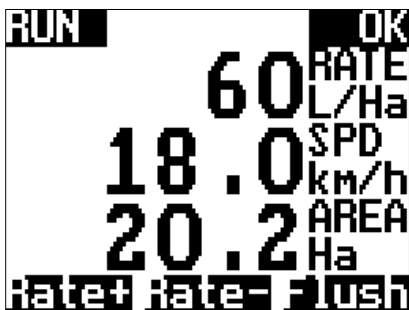

The **Rate + & Rate (STEP)** – allows you to adjust your flow rate with the Pre-Defined **STEP** rate previously input via the Wizard.

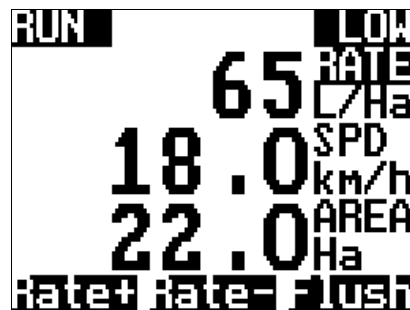

Your **STEP** can be changed via
SETUP > FRONT SCREEN > RATE

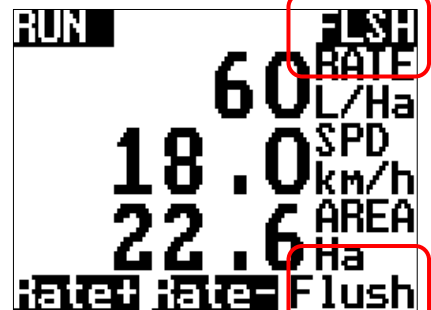

The **FLUSH** function will enable the full flow rate possible on your system.

Dump valve will close & all sections and control valve will open fully.

AREA & SPEED METER SETUP (WIZARD)

The Jackal can display Speed & Area in any combination of km/Ha or mph/acre.

A pickup can be mounted either on a wheel hub or shaft. (Example image right)

NB: THERE SHOULD BE A 5-10MM CLEARANCE BETWEEN SENSOR AND MAGNET WHEN 2 WIRE SENSORS ARE USED.

NEW STYLE, PROXIMITY SENSORS REQUIRE 4MM SENSING DISTANCE. THE PICKUP CAN BE MAGNETIC OR RAISED BOLT HEAD.

Sensors Required:

- Wheel sensor pickup 2 (Reed) or 3 wire (Proximity)
- Magnet (Used with 2 & 3 wire sensor)

Available Connections: Refer to Installing Sensors from **PAGES 9-11.**

NB: The Implement harness has 3 wires by default. If using our standard wheel sensor kit, please only use the black & colored wire. The RED (Positive) does not need to be connected. – Trim this back or cover with heat shrink to prevent shorting out.

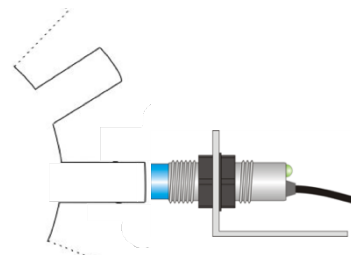
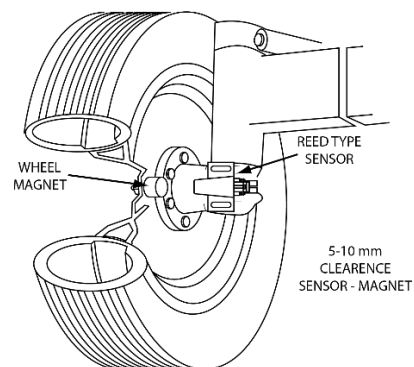

SETUP



From the front screen press **SETUP**



Highlight **WIZARD** and press **SELECT**

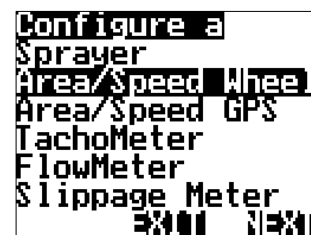

Highlight **Area/Speed Wheel** and Press **NEXT**

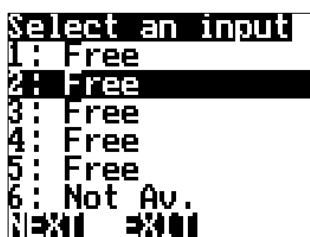

Highlight the **INPUT** number the speed is connected into the back of Jackal & press **NEXT**

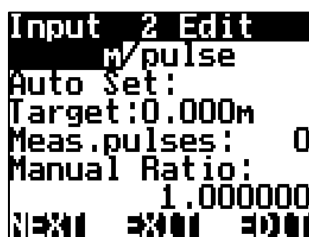

Leave the unit of pulse calibration method as **M**

Choose your calibration method

Auto Set > PAGE 22

Manual Ratio > PAGE 23

CALIBRATION (AUTO SET)

1. Ensure that the sensor and pickup are end-end before continuing
2. Mark bottom centre of tyre on which the sensor is fitted and peg ground in corresponding position
3. Measure out a known distance to calibrate i.e. 20m-100m
4. Peg the corresponding point i.e. at the 20/100m mark

```

Input 2 Edit
m/pulse
Auto Set:
Target:20.000m
Meas.pulses: 0
Manual Ratio:
1.000000
NEXT START EDIT
    
```

Select TARGET

Select EDIT

```

m to Calibrate:
20.0000
EXIT DEL INS
    
```

Using the NAV buttons enter your measured distance. i.e.

20.0000

Press EXIT when done.

```

Input 2 Edit
m/pulse
Auto Set:
Target:20.000m
Meas.pulses: 0
Manual Ratio:
1.000000
NEXT START EDIT
    
```

Press START and move forward slowly.

This will allow pulses to register.

```

Input 2 Edit
m/pulse
Auto Set:
Target:20.000m
Meas.pulses: 66
Manual Ratio:
1.000000
STOP
    
```

When you arrive at the center mark point of tyre to peg press STOP

```

Input 2 Edit
m/pulse
Auto Set:
Target:20.000m
Meas.pulses: 66
Manual Ratio:
1.000000
CALC
    
```

Press CALC. This will divide the distance travelled by the number of pulses registered.

```

Input 2 Edit
m/pulse
Auto Set:
Target:20.000m
Meas.pulses: 66
Manual Ratio:
0.303030
NEXT START EDIT
    
```

MANUAL RATIO will now be updated to reflect the calibration factor.

Press NEXT

```

Other Settings
Speed Input: 2
No. Sections:N/A
Implement Width:
12.000m
Section1: N/A
Section2: N/A
NEXT EXIT EDIT
    
```

Using the NAV buttons and pressing EDIT enter your implement width in (m). e.g.

12m

Press NEXT

```

Units of Display
1: Ha
2: Ac
3: m^2
4: km^2
NEXT EXIT
    
```

Using the NAV buttons select how you would like the area to be displayed on the front screen.

Press NEXT

```

Alarm Settings
Alarm Min: 0.00
Alarm Max: 0.00
NEXT EXIT EDIT
    
```

You have the option to set Alarm Min/Max points if required. Using the NAV buttons select and EDIT as required. Press NEXT

```

Select a Name
Current:
AREA
NEXT BACK EDIT
    
```

Change the input name if you desire, Press EDIT, Press NEXT

```

Display km/h
on front screen?
YES EXIT NO
    
```

Select either YES or NO to display Speed on the front screen with the area covered.

```

Select a Name
Current:
SPD
NEXT BACK EDIT
    
```

Change the input name if you desire, Press EDIT Press NEXT

```

Wizard
Configuration
Successful
NEXT
    
```

Press NEXT to finalise the Wizard and return to the front screen

```

RUN
AREA
3.03 Ha
SPD
10.8 km/h
ALARM DRIP SETUP
    
```

THIS ENDS THE AUTO SET WIZARD SETUP FOR SPEED/AREA METER

CALIBRATION (MANUAL RATIO)

1. Ensure that the sensor and pickup are end-end before continuing
2. Mark bottom centre of tyre on which the sensor is fitted and mark ground in corresponding position
3. Drive ONE full rotation of the wheel, returning the mark point on tyre to bottom centre
4. Measure between the two points.
 - o This is your Manual Ratio (Example 1.24m)

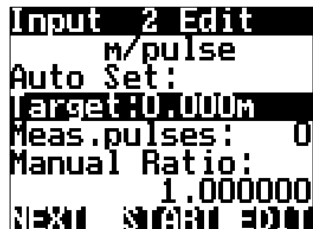

Select MANUAL RATIO
Select EDIT



Using the NAV buttons enter your measured distance. i.e. 1.240000
Press EXIT when done.

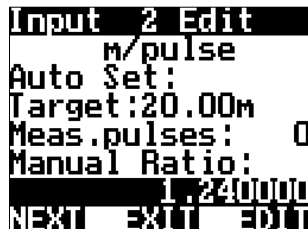

Press NEXT

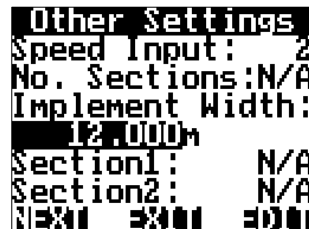

Using the NAV buttons and pressing EDIT enter your implement width in (m). e.g. 12m
Press NEXT

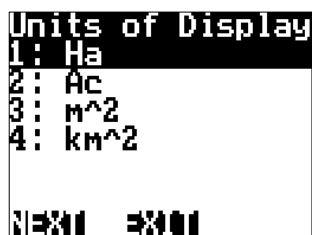

Using the NAV buttons select how you would like the area to be displayed on the front screen.
Press NEXT

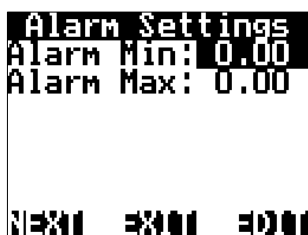

You have the option to set Alarm Min/Max points if required. Using the NAV buttons select and EDIT as required. Press NEXT

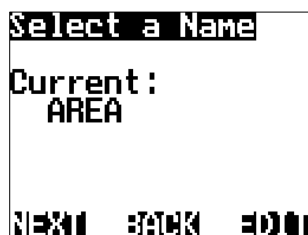

Change the input name if you desire, Press EDIT
Press NEXT



Select either YES or NO to display Speed on the front screen with the area covered.

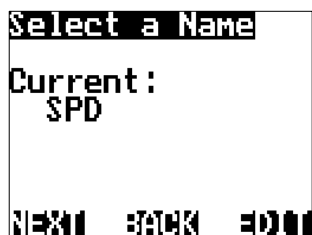

Change the input name if you desire, Press EDIT,
Press NEXT



Press NEXT to finalise the Wizard and return to the front screen



THIS ENDS THE MANUAL RATIO SET WIZARD SETUP FOR SPEED/AREA METER

AREA & SPEED METER USING GPS SETUP (WIZARD)

The Jackal can display Speed & Area in any combination of km/Ha or mph/acre.

A wheel sensor is not required when using a GPS. GPS purchased from Farmscan are pre-programmed. If you BYO please ensure the following:

- GPS programmed with RMC – GGA - VTG NMEA messages.
- Any Baud Rate of - 4800,9600,19200,38400,115200 @ 5hz minimum.

Available Connections: Refer to Installing Sensors from **PAGES 9-11**



SETUP



From the front screen press
SETUP



Highlight **WIZARD** and press
SELECT

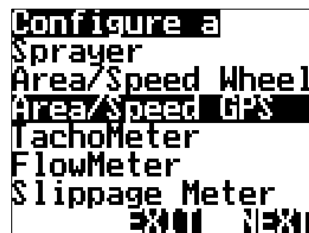

Highlight **AREA/SPEED GPS**
and press **NEXT**

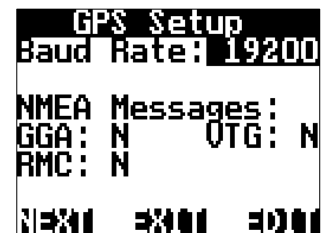

Press the **EDIT** button to
change the baud rate, when
the correct baud rate is
selected the corresponding
NMEA message will be
acknowledged with a Y.
Press **NEXT**

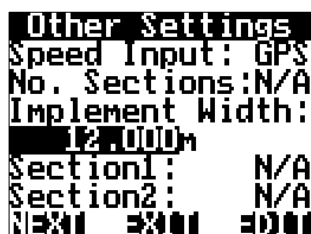

Using the **NAV** buttons and
pressing **EDIT** enter your
implement width in (m). e.g.
12m
Press **NEXT**

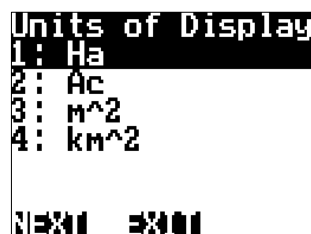

Using the **NAV** buttons select
how you would like the area
to be displayed on the front
screen.
Press **NEXT**

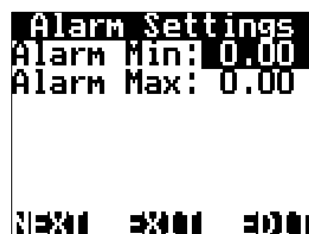

You have the option to set
Alarm Min/Max points if
required. Using the **NAV**
buttons select and **EDIT** as
required. Press **NEXT**

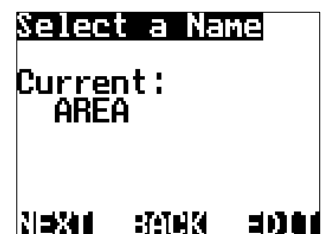

Name the input if you desire,
Press **EDIT**. e.g. **SPEED**
Press **NEXT**



Select either **YES** or **NO** to
display Speed on the front
screen with the area covered.

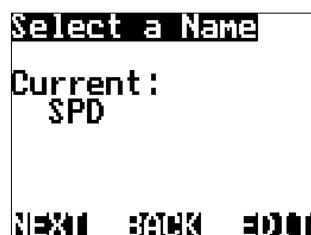

Change the input name if you
desire, Press **EDIT**,
Press **NEXT**



Press **NEXT** to finalise the
Wizard and return to the
front screen



**THIS ENDS THE
SETUP FOR SPEED/AREA
METER USING
GPS INPUT**

TACHOMETER - RPM METER SETUP (WIZARD)

The Jackal can display an rpm (Revolutions per minute) which is useful for monitoring fans or shafts. Available in slow & fast options.

NB: THERE SHOULD BE A 5-10MM CLEARANCE BETWEEN SENSOR AND MAGNET OR 4MM BETWEEN PROX AND PICKUP AND PICKUP

Sensors Required

- Shaft Sensor pickup 2 (Reed) or 3 wire (Proximity)
- Magnet (Used with 2 & 3 wire sensor)

Available Connections: Refer to Installing Sensors from **PAGES 9-11**

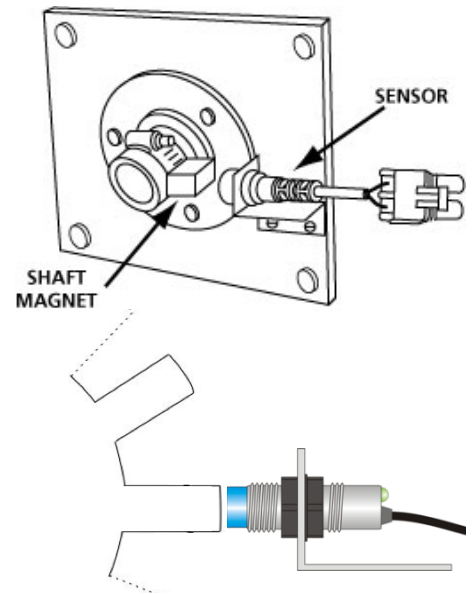

SETUP



From the front screen press
SETUP



Highlight **WIZARD** and press
SELECT

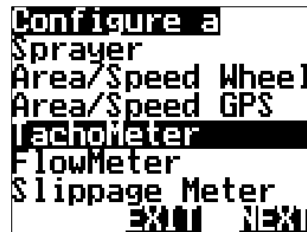

Highlight **TACHOMETER** and
press **NEXT**

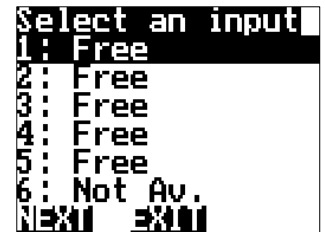

Highlight and select the
appropriate sensor **INPUT**
and press **NEXT**



Leave the default value of
pulse/rev and press **NEXT**



Select **MANUAL RATIO**
Select **EDIT**

The manual ratio is the
number of magnets or bolt
heads/teeth (for proximity).
In most cases the ratio will be
1.

or Press **NEXT**

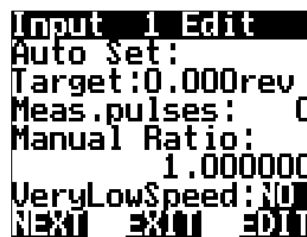

FOR LOW RPM
(1rpm-20rpm)

Press the **DOWN** button and
change **VeryLowSpeed** from
NO to **YES** by pressing **EDIT**

Press **NEXT** when done

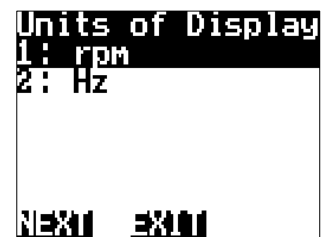

Leave the default value of
RPM.

Select **NEXT**

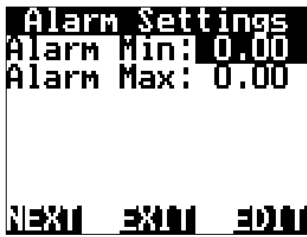

You have the option to set Alarm Min/Max points if required. Using the NAV buttons select and EDIT as required. Press NEXT

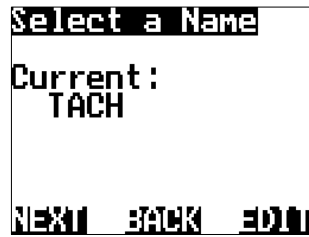

Change the input name if you desire, Press EDIT, Press NEXT



Press NEXT to finalise the Wizard and return to the front screen



THIS ENDS THE WIZARD SETUP FOR A TACHOMETER

FLOW METER SETUP (WIZARD)

The Jackal can be configured to monitor liquid products. If only one input is used the Jackal main screen will display the flow information of your choice. If the Jackal is also setup and installed with a Wheel Sensor input, the Jackal can be setup to display L/Ha for example.



NB: AT NO STAGE CAN THE JACKAL MONITOR TAKE INTO ACCOUNT MULTIPLE SPRAY SECTIONS TURNING ON/OFF. TALK TO US ABOUT THE JACKAL CONTROL SERIES.

Sensors Required

- 3 Wire Flow Sensor (Square Wave)

Available Connections: Refer to Installing Sensors from **PAGES 9-11**

The example uses Input 2 – Polmac Flow Sensor



SETUP



From the front screen press
SETUP



Highlight **WIZARD** and press
SELECT

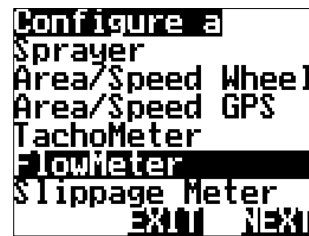

Highlight **FLOWMETER** and
press **NEXT**

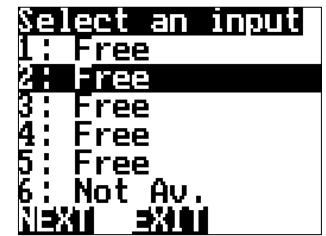

Highlight and select the
appropriate sensor **INPUT** as
described above and press
NEXT

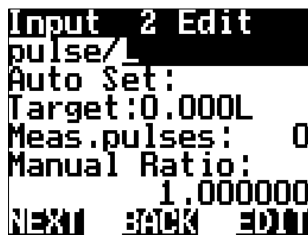

Edit the unit of Pulse or leave
as is.

**Choose your
calibration method**

Auto Set > PAGE 28

Manual Ratio > PAGE 29

CALIBRATION (AUTO SET)

1. Ensure tank has water & pump is ready
2. Have a bucket ready to collect the water
3. Have a measuring device to measure the amount of liquid

```

Input 2 Edit
pulse/L
Auto Set:
Target:0.000L
Meas.pulses: 0
Manual Ratio:
1.000000
NEXT START EDIT
    
```

Highlight **TARGET** & press **EDIT**

```

n to Calibrate:
20.0000
EXIT DEL INS
    
```

Using the **NAV** buttons enter the target amount (L) to be measured. i.e. 20.0000
Press **EXIT** when done.

```

Input 2 Edit
pulse/L
Auto Set:
Target:20.00L
Meas.pulses: 0
Manual Ratio:
1.000000
NEXT START EDIT
    
```

Press **START** & let water flow. This will allow pulses from the flow meter to register and the number of pulses will be displayed next to Meas.pulses:

```

Input 2 Edit
pulse/L
Auto Set:
Target:20.00L
Meas.pulses:4540
Manual Ratio:
190.250000
STOP
    
```

When the desired test volume has been reached press **STOP**

```

Input 2 Edit
pulse/L
Auto Set:
Target:20.00L
Meas.pulses:4831
Manual Ratio:
190.250000
CALC
    
```

Press **CALC**. This will divide the measured amount by the number of pulses registered.

```

Input 2 Edit
pulse/L
Auto Set:
Target:20.00L
Meas.pulses:4831
Manual Ratio:
241.550000
NEXT START EDIT
    
```

MANUAL RATIO will now be updated to reflect the calibration factor.

Press **NEXT**

```

Units of Display
1: L/min
2: gal/min
3: m^3/hr
4: m^3/min
5: m^3/s
6: gal/hr
NEXT BACK
    
```

Using the **NAV** buttons select how you would like the **UOD** to be displayed on the front screen.
Press **NEXT**

```

Alarm Settings
Alarm Min: 0.00
Alarm Max: 0.00
NEXT EXIT EDIT
    
```

You have the option to set Alarm Min/Max points if required. Using the **NAV** buttons select & **EDIT** as required. Press **NEXT**

```

Select a Name
Current:
RATE
NEXT BACK EDIT
    
```

Name the input if you desire, Press **EDIT** or Press **NEXT**

```

Wizard
Configuration
Successful
NEXT
    
```

The Wizard is now complete. Press **NEXT**

```

RUN
RATE
62.10 L/min
ALARM TRIP SETUP
    
```

You will be returned to the Front Screen.

THIS ENDS THE AUTO SETUP WIZARD FOR FLOW METER

REFER TO PAGE 30 TO SETUP AS RATE MONITOR L/Ha

CALIBRATION (MANUAL SET)

Manual set allows for the manual input of a known pulse per litre (PPL) factor. The pulse per litre factor can be obtained from the flow meter manufacture or from the plastic tag attached to the flowmeter.



```
Input 2 Edit
pulse/L
Auto Set:
Target:0.000L
Meas.pulses: 0
Manual Ratio:
1.000000
EXIT START EDIT
```

Highlight 1.000000 under
MANUAL RATIO & press EDIT



```
pulse/L:
668.000000
EXIT DEL UNS
```

Using the NAV buttons enter
the PPL factor as displayed on
the flow meter tag.
i.e. 91.2
Press EXIT when done.



```
Input 2 Edit
pulse/L
Auto Set:
Target:0.000L
Meas.pulses: 0
Manual Ratio:
668.000000
EXIT EDIT
```

Press NEXT to accept the new
manual ratio (PPL)

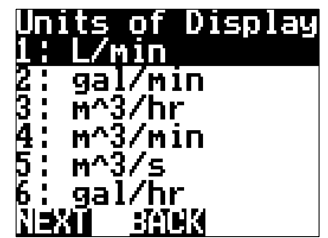

```
Units of Display
1: L/min
2: gal/min
3: m^3/hr
4: m^3/min
5: m^3/s
6: gal/hr
NEXT BACK
```

Using the NAV buttons
select how you would like
the UOD to be displayed on
the front screen.
Press NEXT

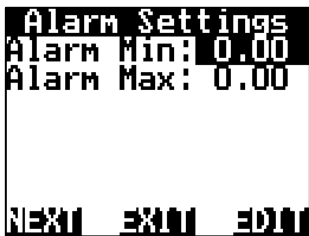

```
Alarm Settings
Alarm Min: 0.00
Alarm Max: 0.00
NEXT EXIT EDIT
```

You have the option to set
Alarm Min/Max points if
required. Using the NAV
buttons select & EDIT as
required. Press NEXT

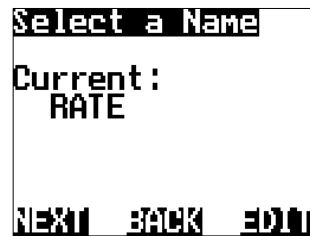

```
Select a Name
Current:
RATE
NEXT BACK EDIT
```

Name the input if you desire,
Press EDIT
or Press NEXT



```
Wizard
Configuration
Successful
NEXT
```

The Wizard is now complete.
Press NEXT



```
RUN
RATE
49.85 L/min
ALARM TRIP SETUP
```

You will be returned to the
Front Screen.

THIS ENDS THE MANUAL CALIBRATION WIZARD SETUP FOR FLOW METER

**** IT IS ADVISED TO CHECK YOUR MANUAL CALIBRATION BY MEASURING OUT A KNOWN QTY TO CONFIRM PPL ****
THIS CAN BE DONE BY COMPLETING THE CALIBRATION AUTO SET ON THE PREVIOUS PAGE (28)

SLIPPAGE METER (WIZARD)

The Jackal Monitor can allow the operator to compare two inputs and provide the result as a percentage. This is applicable when speed over ground is not necessarily equivalent to rotational speed of the wheel/s. This will enable you to set up a comparison between wheel speed and actual speed (using GPS)

Sensors Required:

- Wheel sensor input (wheel or shaft pickup)
- GPS

Available Connections: Refer to Installing Sensors from **PAGES 9-11**

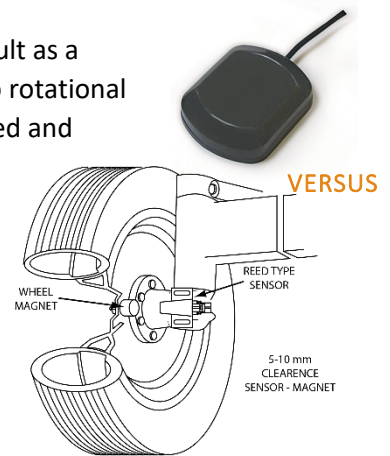

SETUP



From the front screen press **SETUP**



Highlight **WIZARD** & press **SELECT**

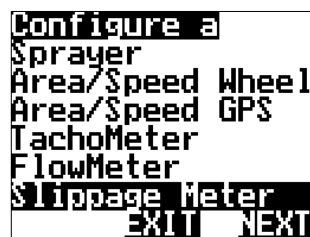

Highlight **SLIPPAGE METER** press **NEXT**



Highlight the **INPUT** number X: the **WHEEL** sensor wire is connected into on the rear of the Jackal & press **NEXT**

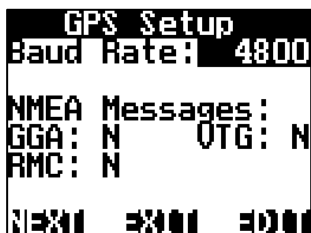

Press the **EDIT** button to change the baud rate, when the correct baud rate is selected the corresponding NMEA message will be acknowledged with a Y. Press **NEXT**

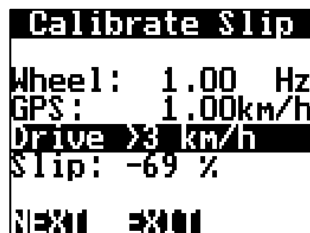

As indicated, drive above 3km/hr

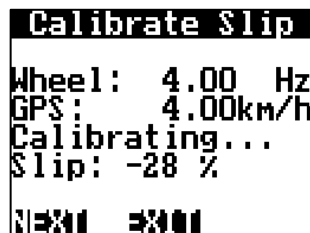

Wheel input will then increment up (displayed in Hz) & GPS speed will start to show.

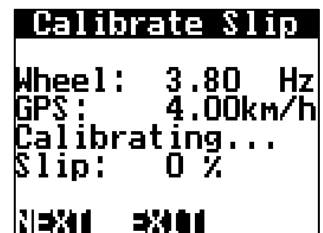

As the system self-calibrates the slip % will get closer to 0%.

When the slip has settled close to 0% press **NEXT**

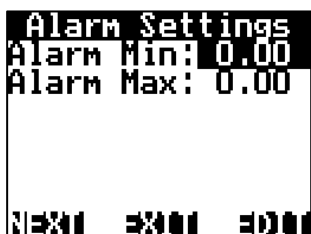

You have the option to set Alarm Min/Max points if required. Using the NAV buttons select & **EDIT** as required. Press **NEXT**

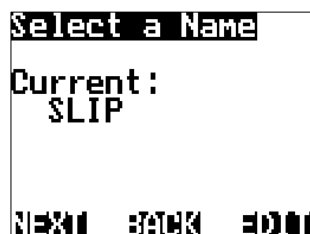

There is no need to **EDIT** the name. It will default to GPS Press **NEXT**



Finally acknowledge that you wish to also display Speed (km/hr) on the front screen with the area covered. Press **YES**



The Wizard is now complete. Press **NEXT**.

THIS ENDS THE SETUP WIZARD FOR WHEEL SLIPPAGE

RATE MONITOR – LIQUID

The Jackal can be setup to display an application rate when using both a speed & flow input.

Rates can be displayed in common formats such as L/Ha

Sensors Required:

- Wheel Sensor/GPS for Speed & Area calculation
- Flow meter (any style) to display Litres

Available Connections: Refer to Installing Sensors from **PAGES 9-11**

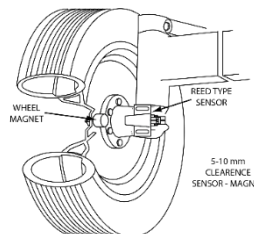

SETUP LIQUID (L/HA)

1. Follow the setup guide on page **21** for “Speed/Area Meter setup”
2. Follow the setup guide on page **27** for “Flow Meter Setup”
3. Follow the steps as described below



From the front screen press **SETUP**



Highlight **FRONT SCREEN** & press **SELECT**

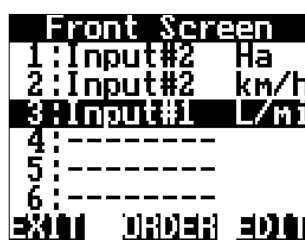

Highlight the line in which the Flow Meter is connected to.

e.g. 3: Input#3 L/min

Press **EDIT**

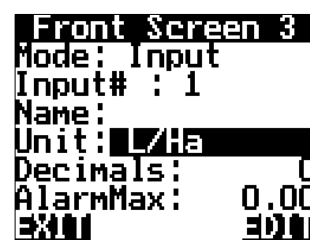

Highlight the **UNIT** & press **EDIT** to change the unit to **L/Ha**.



At no stage can the Jackal take into account multiple sections turning on an off and adjusting the Ha to suit.

This feature is only available in the Jackal Spray Control configuration

Press **EXIT** 3 times to return to the front screen.

Jackal will now display the flow rate as L/Ha with Area & Speed

THIS ENDS THE SETUP FOR RATE METER SETUP AS L/Ha

RATE MONITOR – SOLID

The Jackal can be setup to display an application rate when using both a speed & pulse input from a shaft or other pickup.

Rates can be displayed in common formats such as kg/Ha

Sensors Required

- Shaft sensor kit (2076) - 2 wire or
- Proximity sensor kit (2010P) (3 wire)

Available Connections: Refer to Installing Sensors from **PAGES 9-11**

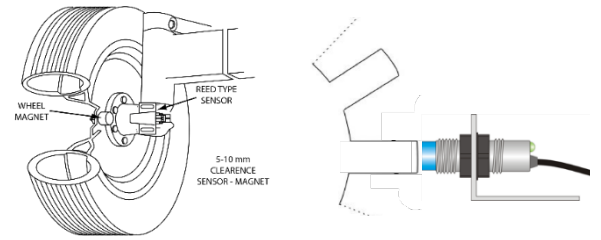

SETUP

1. Follow the steps below to setup the Jackal to display a pulse/kg (**accumulation**)

Note:

- a) Ensure there is product in the bin/tank to calibrate
- b) Have a bucket ready to catch the product
- c) Have a set of scales (e.g. Farmscan Part # 2199) ready to weigh the product



From the front screen press **SETUP**



Highlight **WIZARD** & press **SELECT**

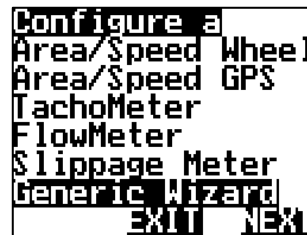

Highlight **GENERIC WIZARD** & press **NEXT**

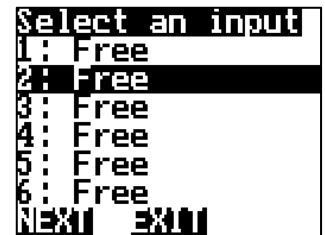

Highlight the **INPUT** number where the sensor wire is connected into on the rear of the Jackal & press **NEXT**

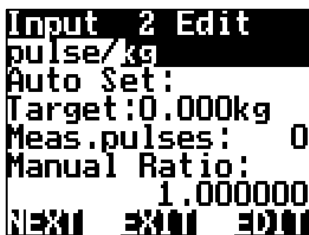

Choose your unit of pulse by pressing the **EDIT**

E.g. pulse/kg



Highlight **TARGET** & press **EDIT**

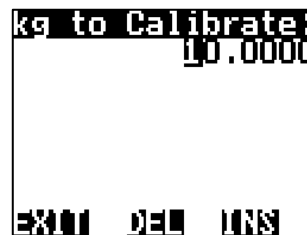

Using the **NAV** buttons enter the target amount (kg) to be measured. i.e. 10.0000 Press **EXIT** when done.

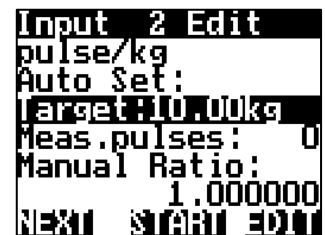

Prime the Bin/Tank until product flows & then stop it. Press **START** on the Jackal, Run Bin & let product flow. This will allow pulses from the sensor to register and the number of pulses will be displayed next to **Meas.pulses:**



When the scales measure the desired test volume, i.e. 10kg, stop the Bin/Tank. Press **STOP**



Press **CALC**. This will divide the measured amount by the number of pulses registered.



MANUAL RATIO will now be updated to reflect the calibration factor. Press **NEXT**

It's recommended to do this test 3 times to get an average pulse count per kg

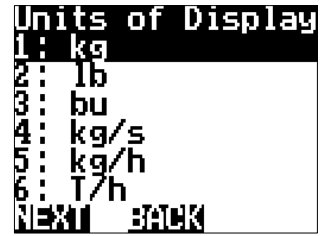

Using the **NAV** buttons select how you would like the Unit of Display to be displayed on the front screen. I.e. **kg**. Press **NEXT**

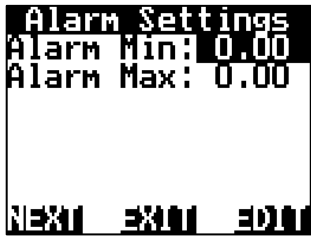

You have the option to set Alarm Min/Max points if required. Using the **NAV** buttons select & **EDIT** as required. Press **NEXT**

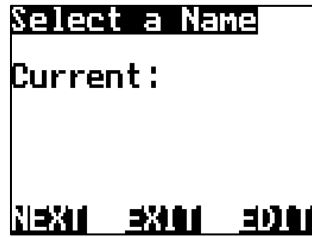

Name the input if you desire, Press **EDIT** or Press **NEXT**



The Wizard is now complete. Press **NEXT**



You will be returned to the Front Screen.

kg will now accumulate

2. Follow the setup guide on **PAGE 21** for "Speed/Area Meter setup"
3. Follow the steps as described below

SETUP SOLID (KG/HA)



From the front screen press **SETUP**



Highlight **FRONT SCREEN** & press **SELECT**

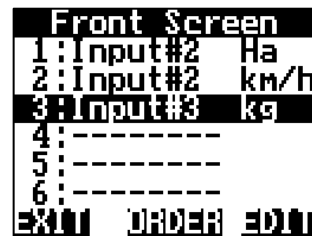

Highlight the line in which the Metering sensor is connected to. e.g. 3: Input#3 kg. Press **EDIT**

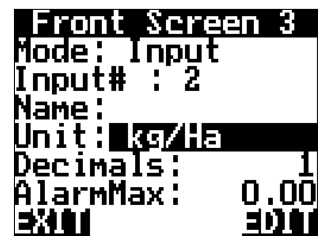

Highlight **UNIT** & press **EDIT** to change the unit to **kg/Ha**.

Change the Decimals displayed if desired also



Press **EXIT** 3 times to return to the front screen.

Jackal will now display the flow rate as L/Ha with Area & Speed

THIS ENDS THE SETUP FOR RATE METER SETUP AS kg/Ha

BATCH METER (JACKAL CONTROL ONLY)

The Jackal can be configured as a Batch Meter to use a flow sensor and optional solenoid valve to meter liquid volumes & cease flow. The output of the Jackal is suitable for direct connection to a 12V solenoid valve.

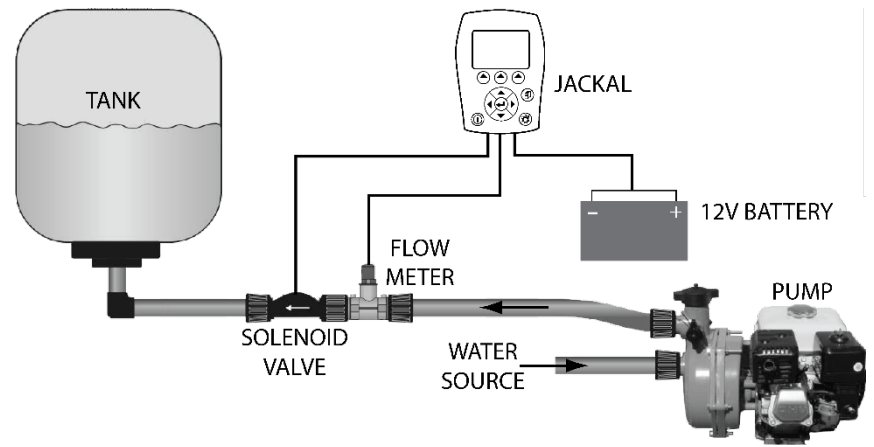

Sensors Required:

- Flow meter (any style)
- 1501 (Optional, from Farmscan) or any 12V Solenoid Valve

Available Connections: Refer to Installing Sensors from **PAGES 9-11**

NB: The Jackal must be unlocked for controller for batch function to work.

SETUP

1. Follow the setup guide on **PAGE 27** for “Flow Meter Setup”



From the front screen press **SETUP**



Highlight **FRONT SCREEN** & press **SELECT**

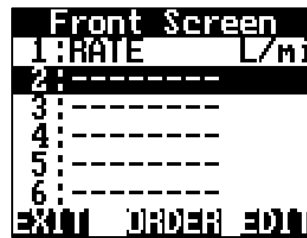

Select an **UNUSED** front screen position & press **EDIT**

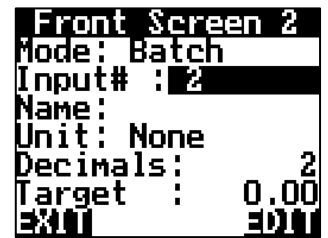

Press **EDIT** to select **BATCH**.
NB: **INPUT #** should match flow meter input. Change if necessary (Normally 2)

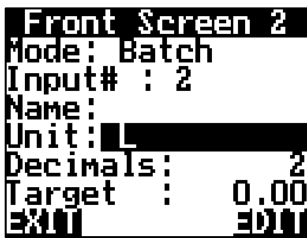

Highlight **UNIT** & press **EDIT** to change Unit to **L**

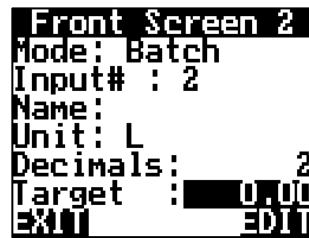

Highlight **TARGET** & press **EDIT** to change the batch volume required.



Using the **NAV** buttons enter the volume required. Press **EXIT** when done

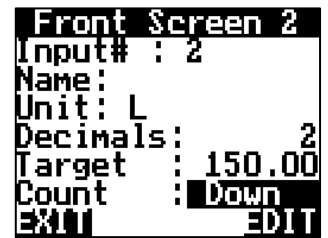

Using the **NAV** buttons press **DOWN** and **EDIT** the **COUNT** to batch **UP** or **DOWN**. Press **EXIT** when done

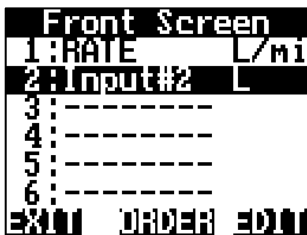

Press **EXIT** again



Highlight **OUTPUTS** & press **SELECT**

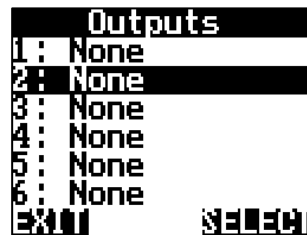

Highlight **2: None** & Press **SELECT** to edit Output 2

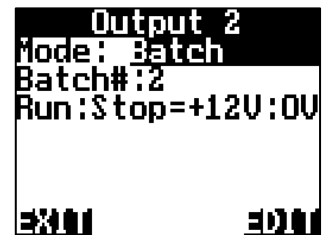

Press **EDIT** and change the **MODE** to **BATCH**

CONTINUE INSTRUCTIONS IF A SOLENOID IS INSTALLED OR SKIP TO OPERATION

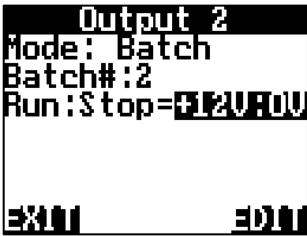

Highlight & EDIT the Run:Stop value to
0V:+12V

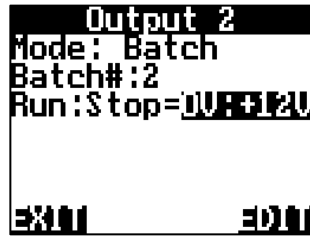

Highlight & EDIT the Run to Stop voltage.
The option allows the output selected to pull from:
+12v to 0V or 0v to 12v

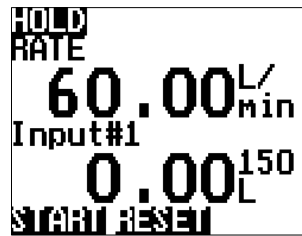

Press EXIT 3 times to return to the Front Screen

IF YOU FIND DURING THE FIRST BATCH OR ON STARTUP YOUR SOLENOID IS WORKING IN REVERSE – CHANGE THE RUN:STOP VALUE

OPERATION

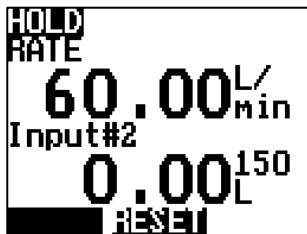

Start by pressing the PAGE button and toggle between

ALARM TRIP SETUP
To
IIIIIIII RESET

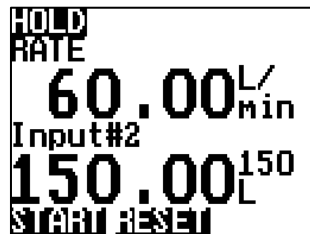

Press RESET to clear the count value followed by START.
Water will flow and the batch will start to either count UP or count DOWN as selected.

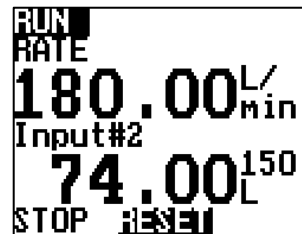

START will toggle to STOP if you need to restart a batch.
RUN/HOLD also performs the same action
Press RESET if required.

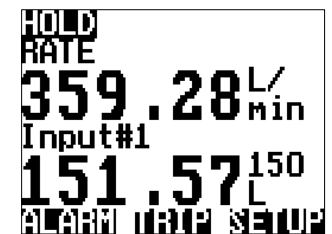

If you need to keep a record of your batch, press the PAGE button and press the TRIP button to save.
More about TRIPS on **PAGE 40**

TIP: If you want to see a Total Litres displayed (rather than L/Min) – Change the FRONT SCREEN value from L/Min to L

Refer to the Flow Meter Setup

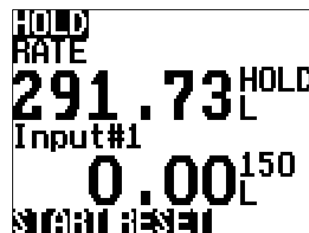

All Values can be reset or saved when using the TRIP functions

THIS ENDS THE SETUP FOR A LIQUID BATCH METER

BIN LEVEL SENSOR

The Jackal can be configured with a bin level sensor for detecting empty/full. All Farmscan sensor will register as High/Low (H/L) for liquid or solid.

Sensors Required:

- Bin Level Sensor (A-2220P Sensor V1)
- Bin Level Sensor (A-2221)
 - Capacitive Sensor V2 – Pictured right >



Available Connections: Refer to Installing Sensors from **PAGES 9-11**

SETUP



From the front screen press **SETUP**



Highlight **WIZARD** & press **SELECT**

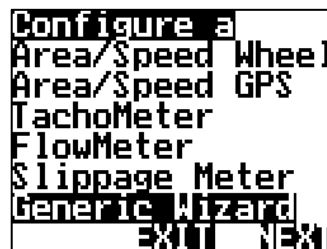

Highlight **GENERIC WIZARD** & press **SELECT**

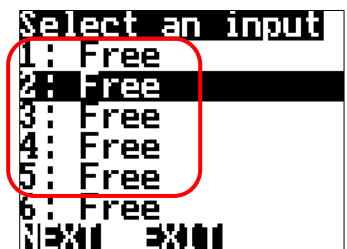

Highlight the **INPUT** number (1-5 or 8-9) to where the sensor wire is connected into on the rear of the Jackal & press **NEXT**

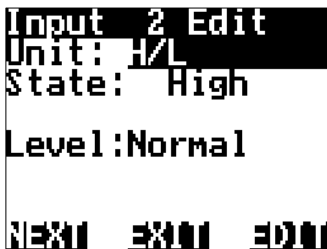

Press **EDIT** to change the unit to **H/L (high/low)** – Other options include On/Off, Full/Empty



State will updated “Live” For example. Low = bin empty, High = bin full. Test by placing hand around sensor.

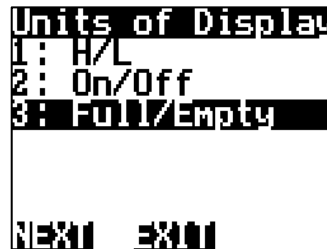

Press **NEXT**
Highlight the Unit of Display that you wish to be displayed on the front screen.
Press **NEXT**

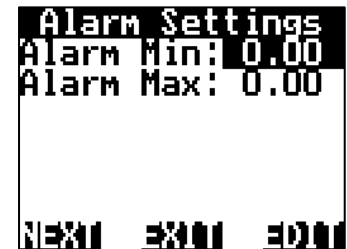

You have the option to set Alarm Min/Max points if required. Using the NAV buttons select & **EDIT** as required.
Press **NEXT**



Name the input if you desire, i.e. BIN1.
Press **EDIT** & **EXIT**



Press **NEXT**.
Wizard is now complete.
Press **NEXT**



Press **EXIT** to return to the front screen
Example - Full



Example - Empty

THIS ENDS THE SETUP FOR A BIN LEVEL SENSOR

AIR/VOLT/DEPTH/%/TEMP PRESSURE SENSOR

The Jackal can be configured to read & display a pressure sensor, voltage, percentage, temperature and display as: kPa, psi, bar, Volt, %, °C. Farmscan recommends sensors that can be powered by 12v but output from 0-5v in a linear style. Call us if you are unsure. There are 2 ports available for this function.



Sensors Required:

- AA-119H or AA-119L (Farmscan Pressure Sensor)
- Any other style that outputs a voltage. I.e. Position sensor (AA-430) for displaying depth as a percentage (%)
- **NB: The Jackal must be unlocked for controller for DEPTH function to work.**



Available Connections: Refer to Installing Sensors from **PAGES 9-11**

The example uses Input 9 – Liquid Pressure Sensor

CALIBRATION (MANUAL)

The example below details setting up a LIQUID PRESSURE SENSOR.



From the front screen press
SETUP



Highlight **WIZARD** & press
SELECT

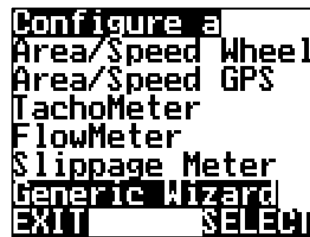

Highlight **GENERIC WIZARD** &
press **SELECT**

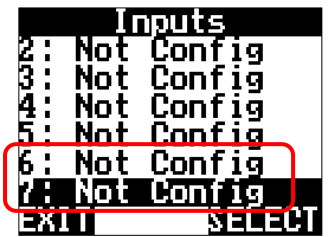

Highlight the **INPUT** number
(6-9) to where the sensor
wire is connected into on the
rear of the Jackal & press
NEXT

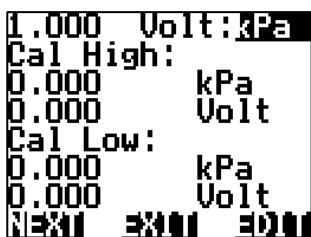

Press **EDIT** to change the
unit. kPa, psi, bar, Volt, %, °C.
i.e. kPa

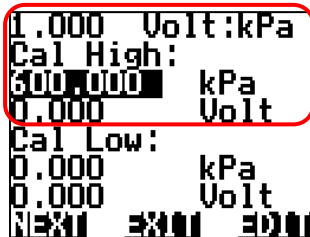

Highlight the 1st **CAL HIGH**
value and **EDIT** the field to
set the maximum the device
will be able to display. I.e.
600kPa. Current input
voltage of input is displayed
in the top left corner.

**NB: If manufacture values
are not available, please
refer to PAGE 39 for LIVE
calibration instructions**

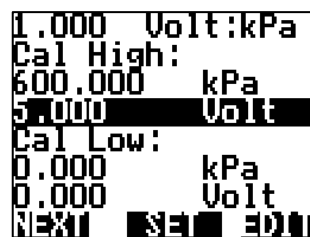

Using the manufactures
guide set the maximum
voltage of the sensor.
e.g. 5.000v by pressing **EDIT**

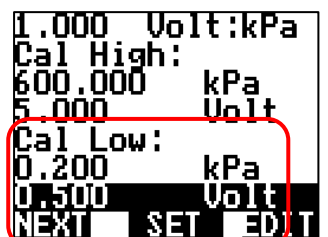

Repeat the previous 2 steps
to set the minimum range of
the sensor.
Press **NEXT** when done

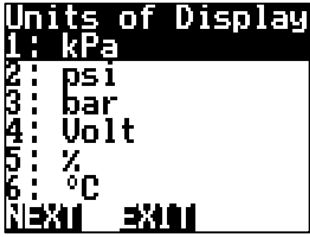

. Highlight or confirm the UOD (Unit of Display) eg kPa.
Press **NEXT** when done

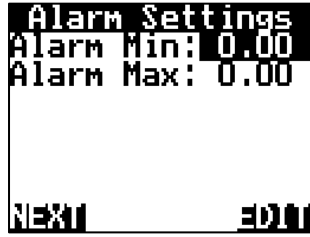

You have the option to set Alarm Min/Max points if required. Using the NAV buttons select & **EDIT** as required. Press **NEXT**

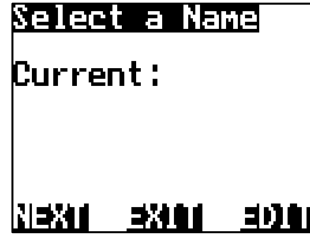

Name the input if you desire, Press **EDIT** or Press **NEXT**



The Wizard is now complete. Press **NEXT**

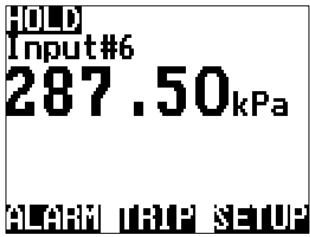

You will be returned to the front screen

THIS ENDS THE MANUAL SETUP FOR A VARIABLE VOLTAGE INPUT SENSOR (LIQUID)

CALIBRATION (LIVE READOUT)

The Jackal also allows for a semi-automatic setup when the voltage values are unknown for a particular voltage input. A live voltage readout is displayed in the top left-hand side when the sensor is active.

Follow the previous 5 steps, followed by:

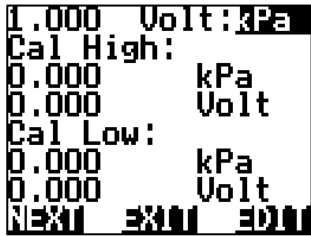

Press **EDIT** to change the unit. kPa,psi,bar,Volt,%,°C.
i.e. kPa

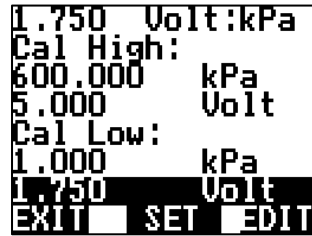

Engage the implement and/or adjust the pressure manually to the low point the sensor will need to operate in.

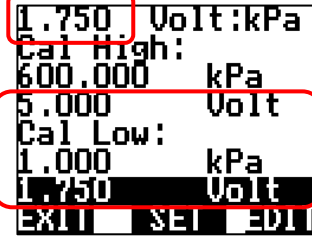

The voltage will now be displayed. e.g. 1.75v.
In the above example we can set the minimum of 1kPa by **HIGHLIGHTING & EDITING** the values as required.

Press **SET**. This will copy the live voltage into the **CAL LOW** voltage point

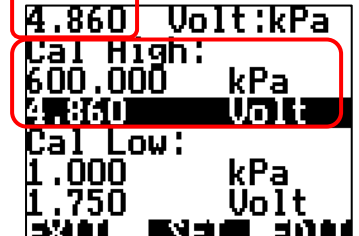

Repeat the previous 2 steps for the **CAL HIGH** values

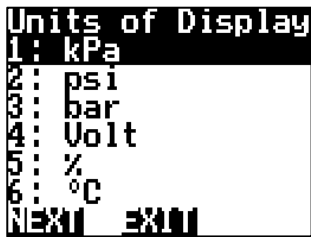

Highlight or confirm the UOD (Unit of Display)
e.g. kPa
Press **NEXT** when done

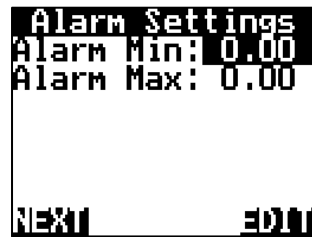

You have the option to set Alarm Min/Max points if required. Using the NAV buttons select & **EDIT** as required. Press **NEXT**

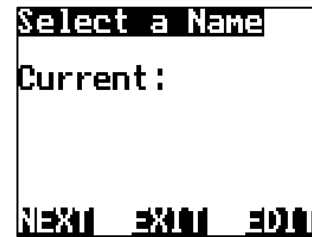

Name the input if you desire,
Press **EDIT**
or Press **NEXT**



The Wizard is now complete.
Press **NEXT**

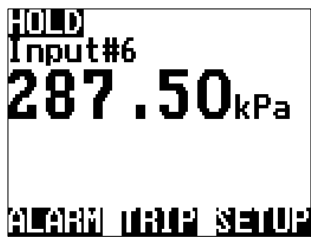

You will be returned to the front screen

THIS ENDS THE AUTO SETUP FOR A VARIABLE VOLTAGE INPUT SENSOR (LIQUID)

TRIPS

The Trips page allows accumulating values to be saved and recalled at a later time.

Examples include Area, Distance, Weight, Volume etc. Instantaneous readings such as Speed, Flow & Rate etc. are not able to be recorded.

- From the front-page press **TRIP**



The screen above allows you to **SAVE/RESET** individual trips or view **SAVED TRIPS**



By pressing the **SAVE/RESET** you have the ability to **Reset Trip | Save Trip | Reset All**

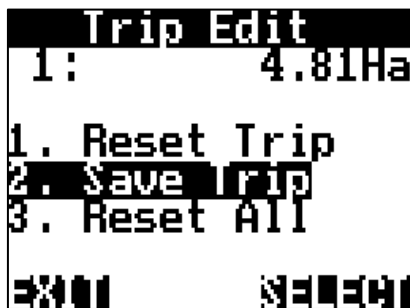

By pressing **2. Save Trip** it will be stored in the **SAVED TRIPS** option

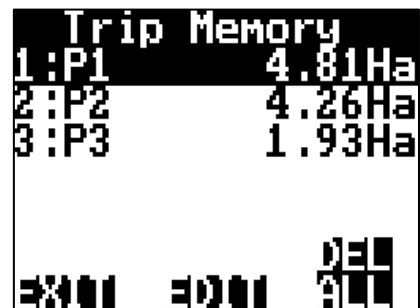

You can now view the **SAVED TRIPS**. You also have the ability to **EDIT** and name the Trip or **DEL ALL** (Delete All Trips)

When you return to the **TRIPS** page the Trip will continue to accumulate. (Like above)
You will need to **SAVE/RESET** the trip if you want to start from Zero (0) again

ALARMS

Alarms are set on a per-front-screen-display-line basis. High/Low Alarm points can be set for any input including: speed, hectares, RPM, Pressure, Bin/Tank Levels.

Alarms will be displayed visually (on screen flash) and made audible.

- To **EDIT** your alarms re-run the wizard by pressing **SETUP** from the front screen.
- OR – **RUN SCREEN > SETUP > FRONT SCREEN**

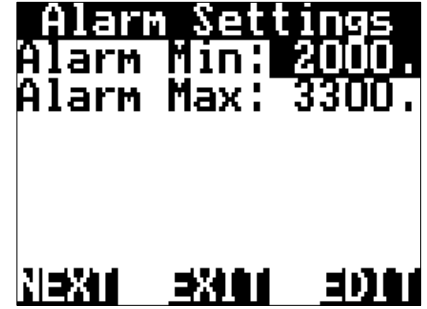

Your existing settings will not be lost during the wizard re-run.

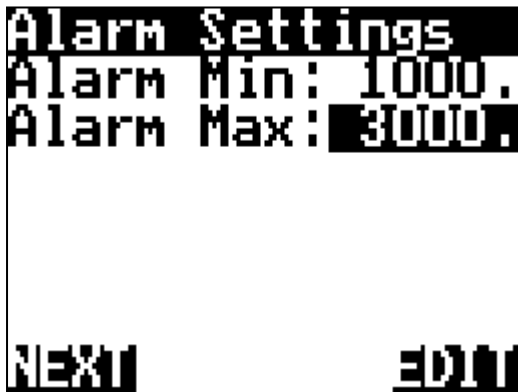

Wizard (Above) or Manual (Right) alarm points.
Example of a Shaft Alarm set at Min of **1000rpm** & Max of **3000rpm**.
Press **EDIT** to adjust these values

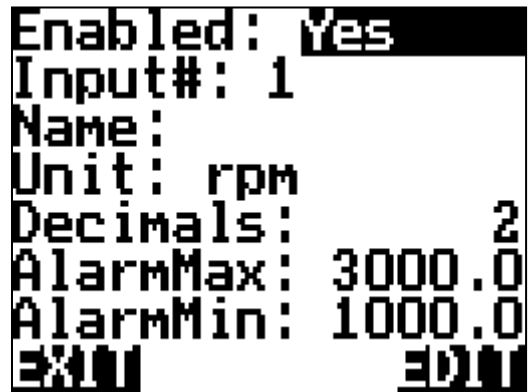

Manual/User setup Alarm points via the **MENU > FRONT SCREEN > EDIT Input #**



When the alarm point is reached e.g.: over 3000rpm the line will **FLASH** notifying you of the alarm point.

Press **ALARM** to enter the page showing all Alarms (active and inactive) to reset the alarm.

**REFER TO OUTPUTS ON PAGE 44
IF YOU WANT TO CONNECT AN
EXTERNAL ALARM**



In the example above Line 1 is **^** over the alarm set point. If it was below it would show 1v.
You have 3 options:

=AUTO: As soon as the value moves back within the Min & Max range the monitor will automatically reset the alarm.

=ON: When the alarm is activated it will remain ON until you enter the ALARM menu and manually reset

=OFF: You can disable the alarm altogether

INPUTS

Each Input Is designated to display certain values as described below.

Ensure you are plugged into the appropriate port for your sensor.

RUN SCREEN > SETUP > INPUTS

- **Input 1-5 (A1-A5) & 8-9 (B3-B4) -Square Wave**
 - m/ft/yd/in/km/mi/pulse
 - pulse/kg/lb/L/gal/bu/rev/bale/unit/each/T/m³
 - Full/Empty – On/Off – H/L
- **Input 6 & 7 (A6 & B2) – Varying Voltage**
 - Volt: kPa/psi/bar/volt/%/°C/

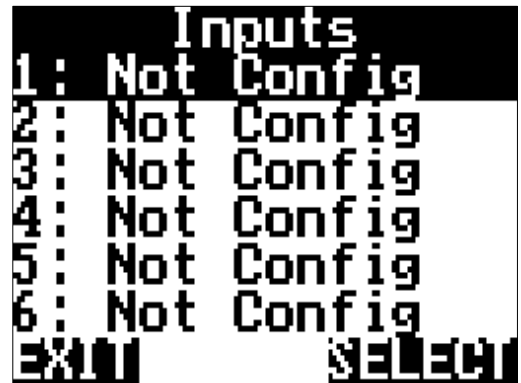

Once your inputs are setup and calibrated you now need to display them on the front screen

GENERIC WIZARD

The generic wizard allows to manually setup your Jackal in a customised method. You can also setup the Jackal to your requirements without using the wizard and navigating each menu by enabling and calibrating each port as required. Refer to the previous wizard guides to assist with manual setup.



From the front screen press **SETUP**



Highlight **WIAZRD** & press **SELECT**

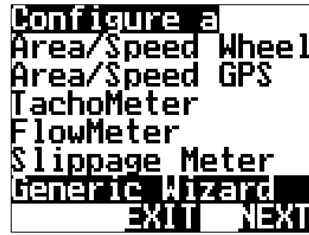

Highlight **GENERIC WIZARD** & press **SELECT**

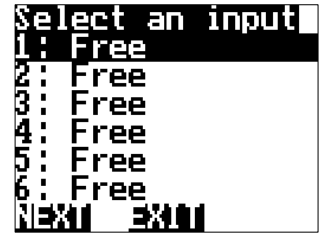

Highlight the appropriate port the sensor is connect to and press **NEXT**

FRONT SCREEN

RUN SCREEN > SETUP > FRONT SCREEN

When your inputs have been enabled and calibrated you can now choose to display the values in our chosen formats on the front screen. You can have up to 3-line items per page and viewable at all times. If more lines are added you can use the NAV buttons to scroll through each screen.

NB: Selectable units relate to the input type. E.g: **Input 1** setup as a **rev/pulse** could display **rpm** or **hz** as the unit



From the front screen press **SETUP**



Highlight **FRONT SCREEN** & press **SELECT**



Highlight the line you want to display the first value & press **EDIT**

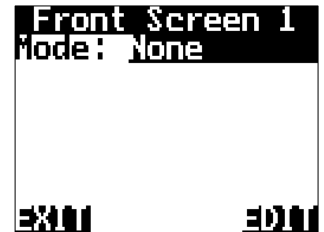

Press **EDIT** to enable the line mode

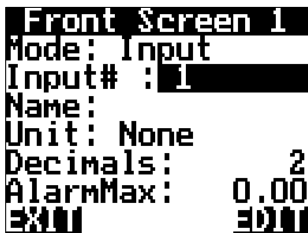

Highlight **INPUT #** and press **EDIT** to associate the calibrated **INPUT** to the line

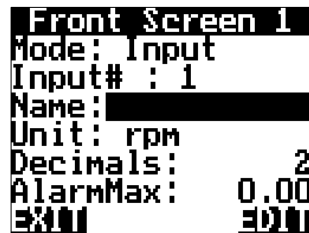

Highlight **NAME** and **EDIT** the input name for easy identification. Eg Shaft

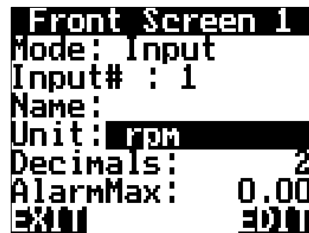

Highlight **UNIT** and press **EDIT** to select the appropriate unit associated with the calibrated input

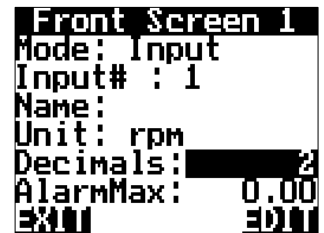

Highlight **DECIMALS** and press **EDIT** to change the number of decimals displayed on the front screen

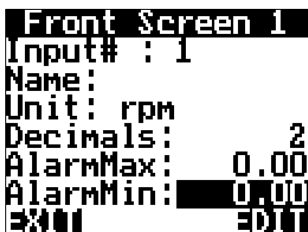

Highlight and **EDIT** the Max & Min Alarm settings if required

FRONT SCREEN (ORDER)

The front screen menu allows you to order the front screen line items. Highlight the line you wish to move, press **ORDER** (a * will appear to the left) then press **PLACE** to accept when you have chosen the new order.

```

Front Screen
1:Input#1 rpm
2:Input#2 Ha
3:Input#2 km/h
4:-----
5:-----
6:-----
EXIT ORDER
    
```

```

Front Screen
1*Input#2 km/h
2:Input#1 rpm
3:Input#2 Ha
4:-----
5:-----
6:-----
PLACE
    
```

```

Front Screen
1:Input#2 km/h
2:Input#1 rpm
3:Input#2 Ha
4:-----
5:-----
6:-----
EXIT ORDER
    
```

OTHER SETTINGS

RUN SCREEN > SETUP > OTHER SETTINGS

Other Settings is used to edit the following options.

```

Other Settings
Speed Input: 4
No. Sections: 3
Implement Width:
12.000m
Section1: 4.000
Section2: 4.000
EXIT EDIT
    
```

Quickly **EDIT** the **Speed Input**

```

Other Settings
Speed Input: 4
No. Sections: 3
Implement Width:
12.000m
Section1: 4.000
Section2: 4.000
EXIT EDIT
    
```

Quickly **EDIT** the **Implement width, Number of Sections & Individual Section Widths**

```

Other Settings
12.000m
Section1: 4.000
Section2: 4.000
Section3: 4.000
Extern.Run/Hold:
Disabled
EXIT EDIT
    
```

Enable/Disable External Run/Hold Function (As described on **PAGE 11-12**)

```

Other Settings
Section2: 4.000
Section3: 4.000
Extern.Run/Hold:
Disabled
AlarmBeep: 2s
EXIT EDIT
    
```

By changing the **Alarm Beep** (in seconds) you can define how long audible "Beeps" can be heard during the Alarm alert before acknowledgment is required. Press **EDIT** to change these options.

```

Other Settings
Section3: 4.000
Extern.Run/Hold:
Disabled
AlarmBeep: 2s
AlarmOnHold: No
EXIT EDIT
    
```

EDIT the **AlarmOnHold** from YES/NO. This option allows you to have alarms active while the Jackal is ON HOLD

```

Other Settings
Disabled
AlarmBeep: 2s
AlarmOnHold: No
Language:
English
EXIT EDIT
    
```

Change the Jackal to your local Language by pressing **EDIT**

```

Other Settings
AlarmBeep: 2s
AlarmOnHold: No
Language:
English
SimultSpeed: No
EXIT EDIT
    
```

Simulate Speed allows you to test the Jackal while stationary.

When the feature is enabled **YES** - return to the front screen to reveal a manual speed adjust.

```

HOLD
ORATE
0.0 L/Ha
0.0 SPD
0.0 AREA
Spd+ Spd- 0km/h
    
```

If the feature does not appear. Press the **PAGE** button reveal the new option. Adjust your speed to the test rate required.

**** Return to the menu to disable when finished ****



OUTPUTS

The Outputs menu should be used with caution and only as described in this instruction guide.

Failure to do this can damage sensors connected to existing inputs.

RUN SCREEN > SETUP > OUTPUTS

The following Outputs are available 1-6

- GND
- + 12v Supply
- Run/Hold
- AlarmAny
 - Ability to activate an external alarm, e.g. External speaker or light. A 12v output will be triggered when AlarmAny is active. – You cannot select an alarm to an output.
- Alarm #
 - Ability to activate an external alarm (as above) on a **chosen port against a specific alarm**. E.g. an external red light could be wired in and activated for a fan alarm and a yellow light could be wired in and activated for a shaft alarm. When multiple alarms are active the available Alarm# will start at “0”
- Batch (As described on **PAGE 34**) – Control Only
- Section (Sprayer Function)
- Rate + (Sprayer Function)
- Rate – (Sprayer Function)
- Dump All (Sprayer Function)
- Dump # (Sprayer Function)
- Clutch All – Control Only
- Clutch # – Control Only
- Section + – Control Only
- Section – – Control Only
- Rate PWM – Control Only
- Rate PVG32 – Control Only
- Rate 5v – Control Only
- Ratio – Control Only
- Volt (Varying Voltage) 0-12v – Control Only

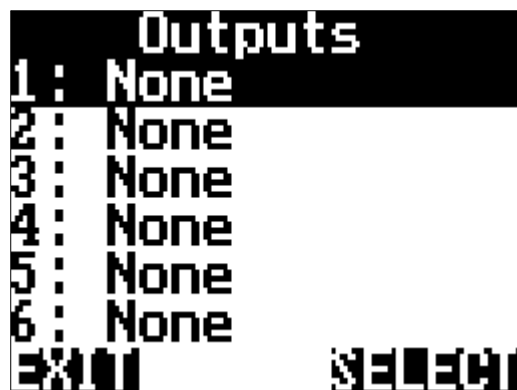

For further explanation of setups of your OUTPUTS please contact our Farmscan Service Department.

FLOW CONTROL VALVE WORKING BACK TO FRONT?

When using the Jackal Spray Wizard outputs are automatically setup for your convenience. However, this information is provided below as an overview of the setup.

In some circumstances your control valve may work back to front, i.e. opening when it should be closing. The output screen allows you to swap the direction rather than change the physical wiring.

Output 1: Rate +

Output 3: Section 1

Output 5: Section 3

Output 2: Rate –

Output 4: Section 2

Output 6: Dump Valve (if installed)

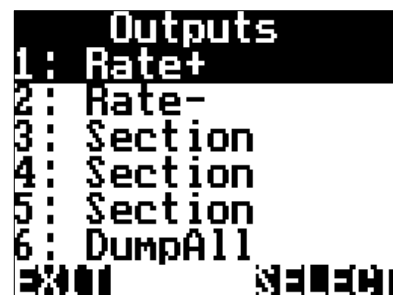

GPS/SERIAL

The GPS/Serial menu allows you to confirm that the GPS connected to the Jackal is function correctly.

By pressing the **SETUP** followed by **EDIT**, confirm the correct strings and Baud rate.

The NMEA messages will change from **N** to **Y**

```
GPS
Date : 00 ---
Time : 00:00:00
Speed: 1.0km/h
Heading: 0°
Long : 0.00000
Lat  : 0.00000
EXIT SETUP

GPS Setup
Baud Rate: 19200
NMEA Messages:
GGA: N OTG: N
RMC: N
EXIT EDIT
```

ABOUT JACKAL

Displays the Firmware version that's installed on the Jackal.

This screen also allows you to **UNLOCK** your Jackal to further functionality.

Please contact Farmscan should you wish to purchase an unlock code.

```
Jackal Version
Aug 1 2018 DEV
Farmscan Ag P/L
farmscanag.com
EXIT UNLOCK
```

DIAGNOSTICS

This screen provides the following information:

- **Voltage** Displays a live input voltage to the Jackal.
- **Current** Displays live Current draw on the Jackal.
- **Input "x"** When inputs are enabled, they will also be displayed for easy diagnostics.

```
Diagnostics
Voltage: 12.00V
Current: 0.10A
EXIT
```

FACTORY RESET

WARNING

This screen allows you to return the Jackal to factory defaults.

All values will be lost after pressing **RESET**.

Power cycle the Jackal to confirm all settings are reset.

```
Factory Reset
This will RESET
ALL settings
back to factory
defaults
EXIT RESET
```

WHEEL FACTOR: PULSES/M RATIO _____

IMPLEMENT WIDTH: _____

SPRAYER WIDTHS: SEC 1 _____ / SEC 2 _____ / SEC 3 _____

FLOW METER PULSES/LITRE RATIO: _____

USE THE CHART BELOW TO COLOUR CODE YOUR WIRING OR MAKE NOTES AGAINST EACH PORT

| A | BOTTOM ROW (GREEN PLUG) | B | TOP ROW (GREY PLUG) |
|-----|--------------------------------|-----|----------------------|
| A1 | INPUT 1 | B1 | GROUND |
| A2 | INPUT 2 | B2 | INPUT 7 |
| A3 | INPUT 3 | B3 | INPUT 8 |
| A4 | INPUT 4 | B4 | INPUT 9 |
| A5 | INPUT 5 | B5 | +12v OUT |
| A6 | INPUT 6 | B6 | OUT 6 |
| A7 | GROUND | B7 | OUT 5 |
| A8 | OUT 2 | B8 | OUT 4 |
| A9 | OUT 1 | B9 | OUT 3 |
| A10 | +12v In +12v Battery | B10 | RS232 TX From GPS |
| A11 | -Ve In Ground / GND Battery | B11 | RS232 RX From GPS |



Sold & Supported by:

Farmscan Pty Ltd
ABN 76 632 674 545

Unit 4, 27 Mordaunt Circuit
Canning Vale WA 6155
AUSTRALIA

SALES PH +61 (8) 6102 3200
SALES FAX +61 (8) 6102 3201

SUPPORT – Powered by AgriSync (Download the APP)
TXT or Call: 0480 018 282 (WST)

sales@farmscan.com.au
www.farmscan.com.au

©2020 Farmscan Pty Ltd

AM-JACKAL-35

JULY 10072020