

spray **controller 24V1uvc**

24V1 Spray Controller

Operator's Manual UVC

February 2004

INTRODUCTION

The Farmscan Spray controller 24V1 was developed to provide advanced spray controlling capabilities whilst maintaining an extremely simple user interface.

The controller has a variety of selectable display and control options that can be configured to suit a specific application or user preference. The controller options and calibration setup can be locked to limit operator access.

The controller incorporates 5 section control switches, master on/off control and foam marker left/right control. Spray controller kits are supplied with 3 or 5 section valves.

A large LCD (liquid crystal display) gives all the information required to operate in one view with readouts for rate, speed, tank level, trip area, trip volume, time and pressure (optional), special icons indicate active control options.

Spray records are maintained for up to 10 fields/paddocks in a separate screen and may be printed out or downloaded to PC based record keeping programs.

The controller may be operated in automatic, manual or GPS (Slave) mode. In automatic and slave mode, the flow control valve responds automatically to speed and pressure variations or partial section shutdown to maintain the target rate. Up and down keys allow manual increment and decrement of the target rate.

In Slave mode, the controller will accept rate commands from a separate guidance/task computer linked to GPS and simultaneously report back on rate applied and active sections for the purpose of rate mapping and verification of sprayed area.

A green "status light" gives visual confirmation the sensors are operating correctly and the system is controlling to the target rate using the last set calibration values.

In the event of an error, an audible warning alerts the operator with a short message displayed to explain the fault.

The 24V1 cab module is connected to a flow sensor and flow control valve on the sprayer by either direct cable connection or via a junction box when using more than 3 section controls, a second spray line or dump valve.

A standard wheel sensor is supplied for ground speed pickup or a radar speed sensor may be connected using the inbuilt radar interface. Alternatively, a Farmscan Smart GPS 3004 can be used to provide ground speed.

An optional pressure sensor may be fitted to provide a pressure readout and pressure lo/hi alarm.

The slow hold and second spray line function may be activated at a preset speed, or will be pressure activated when the optional pressure sensor is used. The pressure sensor option must be used for multi step spray line control.

Equipment supplied on a new sprayer will be plumbed to the manufacturer's specification.

Contents

Introduction	1
Parts List	4
Installation	5
Controller Cab Display	5
Wheel Sensor Installation	6
Wheel Sensor Installation Procedure.....	6
Control Bank Installation – Standard 3 & 5 Section Kits.....	7
Control Bank Installation – Alternative Equipment	8
Explanation of Components.....	9
Pressure Relief Valve (PRV).....	9
Flow Control Valve	9
Flow Sensor	10
Section Valves	10
Second Spray line (Optional).....	10
Second Spray Line Plumbing.....	11
Pressure Sensor (Optional)	13
Dump Valve (Optional)	13
Foam Marker Power	13
Foam Marker Solenoids	13
Connections	13
Connection To Power	16
Spray Controller System TEST.....	17
Operation	18
24V1 Front Panel	18
Status Indicator	18
Switches.....	19
Function Keys	20
Main Display Screen.....	21
Display Settings	21
Display Options	21
Time	22
Message Bar.....	22
Mode Icon.....	23
Records	26
The Print Function (optional).....	27
Slow Hold (Optional)	28
Second Sprayline Operation (Optional)	28
Dump Function (optional).....	29
Diagnosing Problems.....	29
Calibration - Setting Up the 24v1	30
Calibration Locking Function	30
Screen Navigating.....	30
Before Starting - Metric or Imperial.....	31
Step 1- RATE CALIBRATION	32
Rate.....	32
Step Size	32
Mode	32
Step 2 – OPTIONS	33
Pressure.....	33
Radar Interface	33
Second Spray line (Optional).....	33
Second Line Mode.....	34
Dump (Optional).....	34
Valve Time.....	34
Step 3 – SYSTEM SETUP.....	35

24V1 Introduction	3
Calibrate WHEEL Factor	35
Calibrate SECTION WIDTHS	36
Calibrate FLOW SENSOR.....	36
Calibrate PRESSURE SENSOR	37
Calibrate Slow Hold Point	38
Calibrate Second Spray line	39
step 4 - ALARMS.....	40
Tank Alarm.....	40
Rate Alarm	40
Pressure Alarm	40
Sound	41
step 5 TIME & DATE.....	41
step 6 DISPLAY OPTIONS	42
Display Settings	42
SAMPLE SETUP	44
Pin Outs	45
L/100M - Setting Up for Horticultural Row Spraying.....	46
Step 1 - Display 'L/100m'	46
Step 2 - Set Target Rate.....	46
Step 3 - Set Up Section Widths.....	46
Troubleshooting	49
Flow Sensor Service Procedure	53

PARTS LIST

REF	PART No.	DESCRIPTION	QTY
1	A-24V1/5	24V1 CONTROLLER CONSOLE	1
2	AH-405	MONITOR MOUNTING BRACKET	1
3	AH-861	FINGER SCREWS (1/4" x 3/8)	2
4	HG-005	ADHESIVE WASHER 20 x 7 x 1.5 mm	2
5	AC-24V1/T-04	24V1 TRACTOR LOOM 2.5m	1
6	AC-24V1/S/3-04	5 m SPRAYER LOOM 3 SECTION ARAG	1
7	AA-109	PRESSURE SENSOR 0-600kPa	1
8	AC-205	5 m 2 WAY PACKARD EXTENSION CABLE	1
9	AA-24V1/3	ARAG CONTROL 3 SECTION CONTROL BANK	1
10	AA-110P	REED TYPE SENSOR	1
11	AA-133	MINI WHEEL MAGNET AND NUT	6
12	AA-400/SBA	FOAM MARKER COMPRESSOR RELAY	1
13	C-207	5mm RED/BLACK CABLE	20mm
14	HG-616	PACKARD SEAL WATERPROOF – GREEN	2
15	P-077	PACKARD 2 WAY FEMALE HOUSING	1
16	P-083	PACKARD TERMINAL FEMALE	3
17	AH-300	DEUTSCH SOCKET MOUNTING PLATE	1
18	P-173	DEUTSCH LOCKING WASHER	1
19	P-174	DEUTSCH LOCKING NUT	1
20	HG-706	CABLE TIES 290 x 5.0mm	40
21	AM-24V1-UVC	24V1 INSTRUCTION MANUAL V1.0	1
22	AM-24V1Q-1.0	OPERATOR'S QUICKGUIDE 24V1 V1.0	1
23	AM-200	FARMSCAN 2YR WARRANTY CARD	1

INSTALLATION

CONTROLLER CAB DISPLAY

Choose a location in the cab that is convenient to the operator and preferably not in close proximity to mobile telephone or two way radio equipment.

Adhere the two rubber adhesive washers (HG-005) provided in the kit onto the inside of the mounting bracket (AH-405). This prevents the controller from swivelling around once mounted.

Connect main loom to spray controller and lock connector screws firmly.

Run main loom to rear of tractor/spraying vehicle and mount breakaway connector on bracket supplied facing towards sprayer. Avoid contamination from hydraulic couplings.

As a precaution, avoid running controller loom alongside other electrical cables in the cab. Use cable ties supplied to secure cable away from risk of damage.

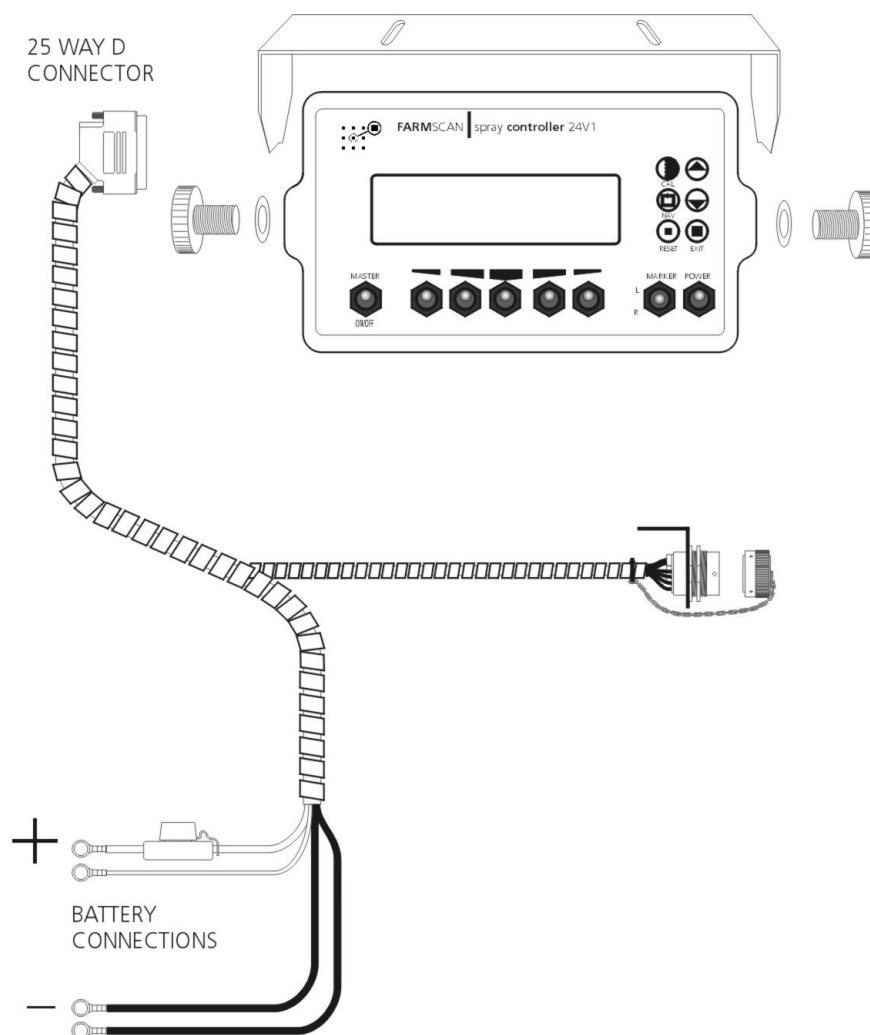

WHEEL SENSOR INSTALLATION

The wheel sensor consists of a reed type sensor (magnetic switch) and wheel magnet to be fitted onto any **undriven** ground wheel of the sprayer. The magnet activates the sensor as it sweeps past.

The spray controller requires at least one wheel pulse per second from the sensor. In circumstances of an extremely large wheel working at slow speeds (less than 5kph), additional wheel magnets may be fitted at equal spacings.

Self propelled or linkage mounted sprayers that do not have an undriven ground wheel can use a radar speed sensor or Farmscan smart GPS antenna 3004 as an alternative. Speedo drive cable sensors are also available for 4WD vehicles and trucks.

Wheel Sensor Installation Procedure

1. Bolt the wheel magnet onto the inside of the wheel in a position that allows the magnet to sweep directly past the wheel sensor within a 5 - 10 mm clearance. Maximum clearance is 15 mm. The bolt in the magnet can be replaced with a longer or shorter bolt as required.

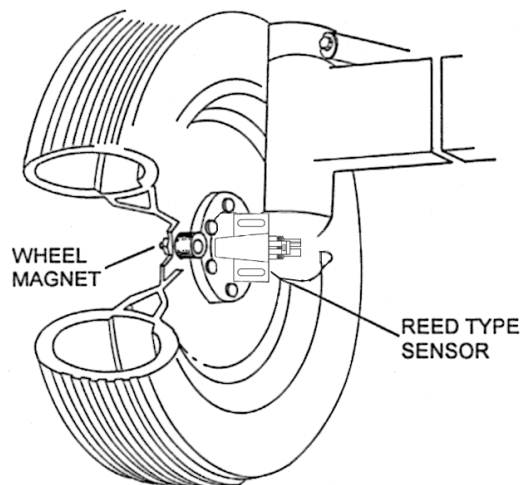

2. The magnet can be mounted anywhere in a radius from the centre of the wheel. Nearer to the hub will ensure the best ground clearance.
3. The sensor must be rigidly bolted to an existing structure, ideally in a protected position to face the magnet as shown.
4. If the sensor is mounted on a steered wheel, make sure the sensor moves with the steering mechanism to maintain constant clearance between the magnet and the sensor when turning from lock to lock.
5. A 5m extension cable is provided to connect the sensor to the sprayer loom connector marked 'wheel'.
6. Use cable ties to secure sensor cable away from risk of damage or chaffing.

Radar/GPS/Speedo Sensor

In applications where an undriven ground wheel is not available, a radar speed sensor, Farmscan smart GPS antenna or speedo cable sensor may be used.

A 3 pin connector marked 'SPEED' is provided in the cab loom as a convenient connection point.

If the tractor has a radar fitted with auxillary connection point, use an optional Farmscan radar adapter cable, then enable the inbuilt radar interface in the controller's OPTIONS MENU 1.

Optional AC-029 John Deere Radar Adapter Cable.

AC-030 Case Radar Adapter Cable.

A complete Farmscan Radar Sensor Kit 2004 is available for installation on your vehicle.

Farmscan Speedo Sensor Kit 2007 is available to suit Japanese speedo drive cables.

Refer to separate installation instructions supplied with optional kits.

CONTROL BANK INSTALLATION – STANDARD 3 & 5 SECTION KITS

The standard 3 and 5 section spray controller kit is supplied with a pre-assembled control bank that includes: pressure relief valve, proportional control valve, flow sensor and section control valves ready to install on *boom sprayers and low volume orchard/vineyard sprayers*.

24V1/5-3A Spray controller Kit – 3 Section Complete.

24V1/5-5A Spray controller Kit – 5 Section Complete.

The optional dump valve and second spray line valve/s will be included in the control bank if ordered with the original equipment, otherwise the control bank will need to be disassembled and fitted with longer bolts to accommodate any optional extra valves.

The control bank must be installed on the sprayer in an *upright position* as shown in diagram, or *undercover* if mounting any other way. Mounting brackets on the control bank may be relocated as necessary.

A junction box is supplied on *5 section systems only* to provide additional connection points for second spray line valve/s, dump valve and foam marker solenoids, 3 section kits do not have facilities for connecting additional valves.

To mount junction box, remove junction box cover and bolt through isolated cavities in corner of box.

Ensure that all cabling leaving the junction box faces downwards, so to prevent water entering the junction box. It is recommended, if possible to mount the junction box inside a sealed cabinet.

See diagram on the next page.

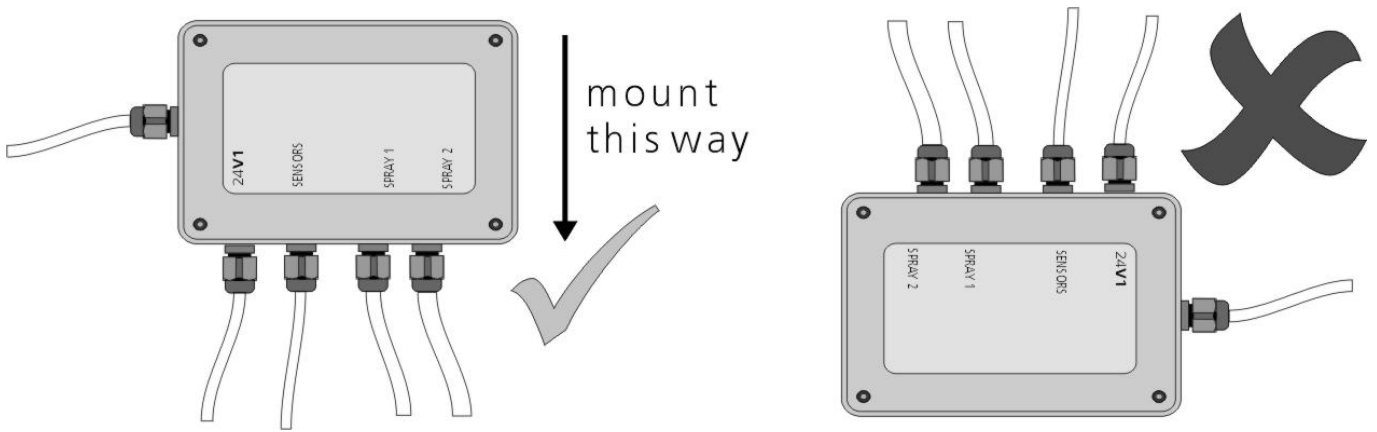

Connect sprayer loom to control bank components as labelled on connector tails and tape any unused connectors back onto main loom.

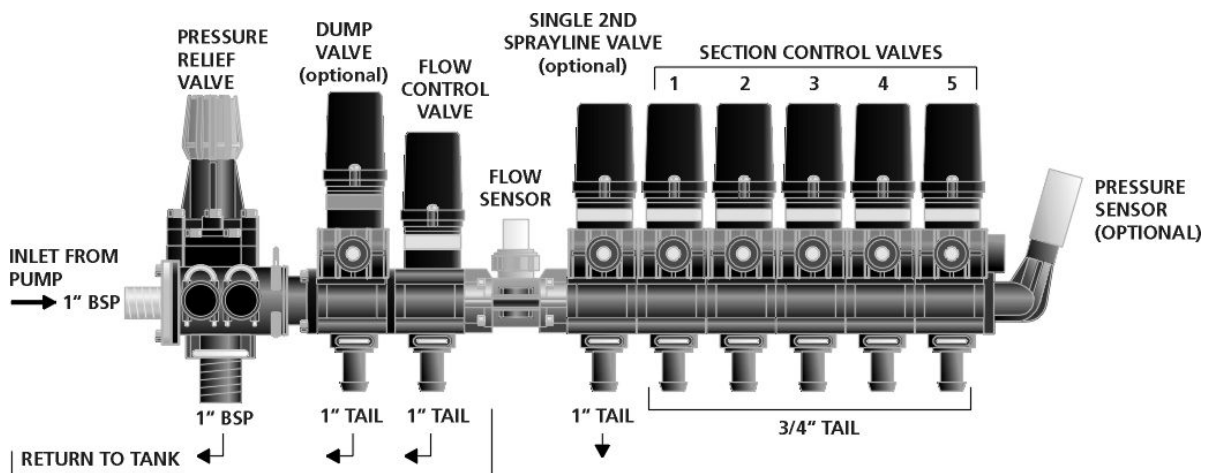

Note: Alternative hose tails or threaded outlets are available separately.

CONTROL BANK INSTALLATION – ALTERNATIVE EQUIPMENT

The spray controller 24V1 kit can be supplied bare (without standard 3 or 5 section control bank) to allow connection of alternative or existing valve/sensor components.

- 24V1/5 – 3 Spray controller Kit – 3 Section (Ex control bank)**
- 24V1/5 – 5 Spray controller Kit – 5 Section (Ex control bank)**

Proportional Control: The flow control valve regulates a proportion of material back to tank, thereby controlling the volume of material delivered to the section controls.

Suitable for broadacre boomsprays and high volume airblast sprayers.

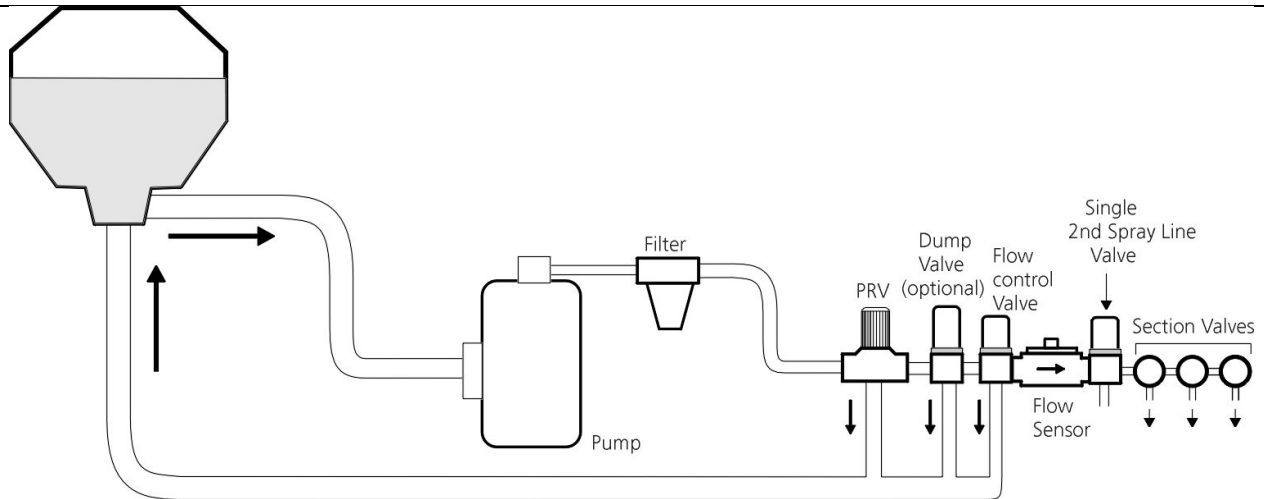
**Direct Control:**

Used to throttle (restrict) the main delivery line thereby regulating the volume of material delivered to the section controls.

Suitable for ultra low volume applications from 1 L/min – 80L/min.

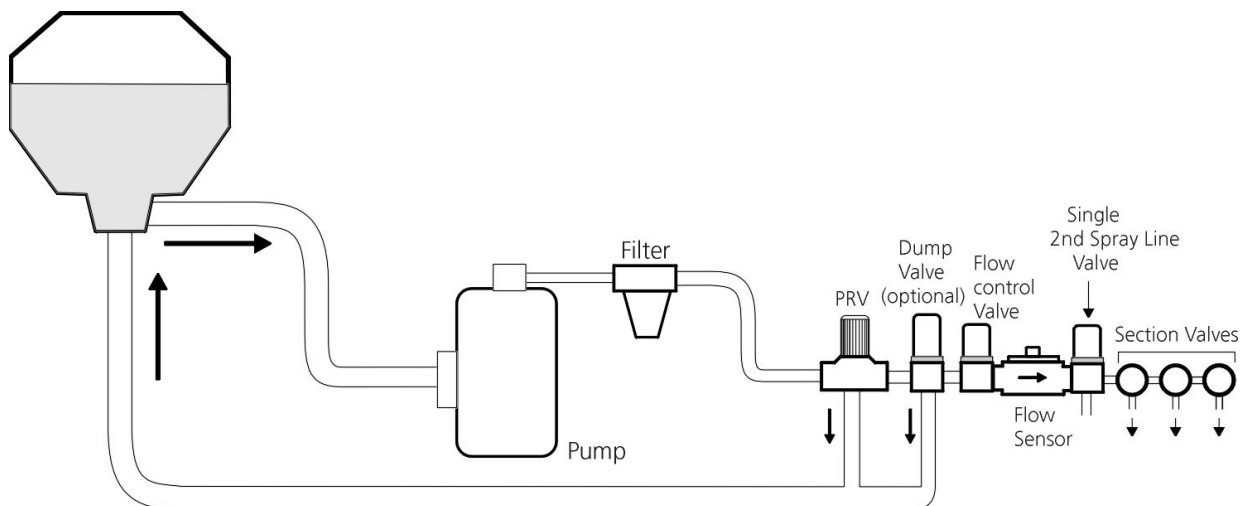
**EXPLANATION OF COMPONENTS****Pressure Relief Valve (PRV)**

The PRV is essential for safe and accurate operation of a positive displacement pump. The PRV is used to set the maximum pressure available to the flow control valve and protects the system by relieving excess pressure back to tank when the section controls are switched off.

Flow Control Valve

The spray controller is designed to operate a DC motorised flow control valve fitted downstream of the PRV, operating either proportional or direct flow control to regulate the main delivery line feeding the flow sensor and section control valves.

Flow Sensor

The flow sensor provides continuous feedback to the spray controller which regulates the flow control valve to maintain the required volume of material delivered to the section valves.

All product delivered through the flow sensor must go to the section control valves only, ie no return line back to tank or pump after the flow sensor.

The sprayer must operate within the minimum and maximum operating range of the flow sensor, otherwise erratic control may result.

Important

Check required minimum and maximum flow rate BEFORE installing the equipment. Alternative flow sensors are available.

Flow rate Calculation:
$$\frac{\text{Rate (L/Ha)} \times \text{Speed (km/h)} \times \text{Width (Metres)}}{600} = \text{L/Min}$$

Example:
$$\frac{50\text{L/Ha} \times 12 \text{ Kph} \times 12\text{m}}{600} = 12\text{L/min}$$

Section Valves

The section valves are controlled by the cab switches to provide partial or complete shutdown of the spray boom sections.

The spray controller will accept 2 wire 12volt solenoid valves rated to *1 amp continuous* draw, 2 wire motorised section valves or 3 wire motorised section valves.

3 wire motorised valves:	Red = +12V, Black = Negative, Colour = Trigger
2 wire motorised valves:	Red = +12V, Black = -12V, Colour = Unused
2 wire solenoid valves:	Red = Unused, Black = Negative, Colour = Trigger

Second Spray line (Optional)

A second spray line is activated automatically when the first spray line reaches a preset maximum pressure, thereby allowing greater flexibility in working speeds and additional capacity to change rates on-the-go.

The second spray line can be activated at a preset speed equal to the first spray line reaching maximum pressure or when using the optional pressure sensor, the second spray line is activated at a preset pressure.

Using pressure activation (eg 300kpa/43psi) avoids the need to change the set activation point when changing rates.

When using **speed based** activation, the second spray line must be fitted with the same size nozzles as the first spray line. Choose nozzles suitable to achieve target rates at lower working speeds then allow double the maximum speed or rate to calculate the full operating range.

When using **pressure based** activation, you can choose single step or multi step operating mode.

With single step operation, fit the same size nozzles in both the first and second spray line as above.

With multi step operation, the first spray line is fitted with nozzles one size smaller than the second spray line. The controller will automatically select first, second or both spray lines to maintain operation within the desired pressure range.

Second Spray Line Plumbing.

The second spray line is fitted to the spray boom with nozzles positioned at half centres to the first spray line (eg, if using 50cm or 20inch spacings for the first line, the second line nozzles should be placed at 25cm or 10inch intervals.) See diagram.

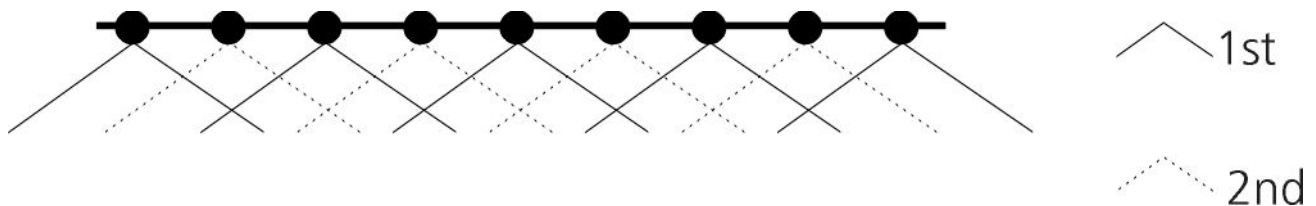

The second spray line can be plumbed as a single section covering the entire boom width or maybe split into multi sections to match the first spray line sections.

Single Second Sprayline.

A single second spray line is adequate in high speed broadacre spraying where section shutdown is relatively infrequent. The controller will automatically shutdown the second spray line if one or more of the first spray line section valves are switched off.

A single second spray line requires one large section valve to activate the second sprayline.

All the second spray line nozzles must be inter-connected on **one** independent hose with multiple infeed points to equalise pressure over the whole width.

The second spray line section valve must tee off the main delivery line *after the flow sensor and flow control valve*.

The second spray line valve is connected to the loom connector marked "2nd Line"

3 wire motorised valves:

2 wire motorised valves:

2 wire solenoid valves:

Red = +12V, Black = Negative, Colour = Trigger

Red = +12V, Black = -12V, Colour = Unused

Red = Unused, Black = Negative, Colour = Trigger

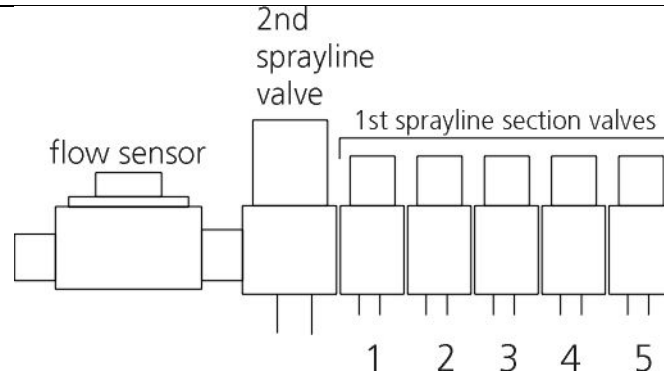

Split Second Sprayline

A split second sprayline is necessary when sections are frequently shutdown during operation.

A split second spray line requires a separate section valve for *each section of the second sprayline*.

Each second line section valve must feed the matching width as covered by each first sprayline section valve.

The first and second spray line section valves should be plumbed onto a common manifold and must tee off the main delivery line *after the flow sensor and flow control valve*.

Connection of split second line valves requires the optional AC-24V1/J/2SL-01 Split Second line loom which feeds through a spare grommet on the junction box to a terminal strip marked "2ND SPRAYLINE".

The terminal strip has provision for 5 second spray line section valves, either 2 wire solenoid type or 3 wire motorised valves.

3 wire motorised valves: Red = +12V,
Black = Negative, Colour = Trigger

2 wire motorised valves: Red = +12V,
Black = -12V, Colour = Unused

2 wire solenoid valves: +12V = Unused,
Black = Negative, Colour = Trigger

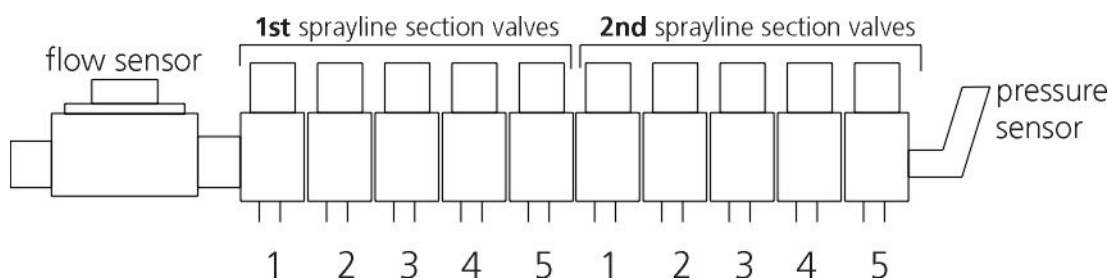
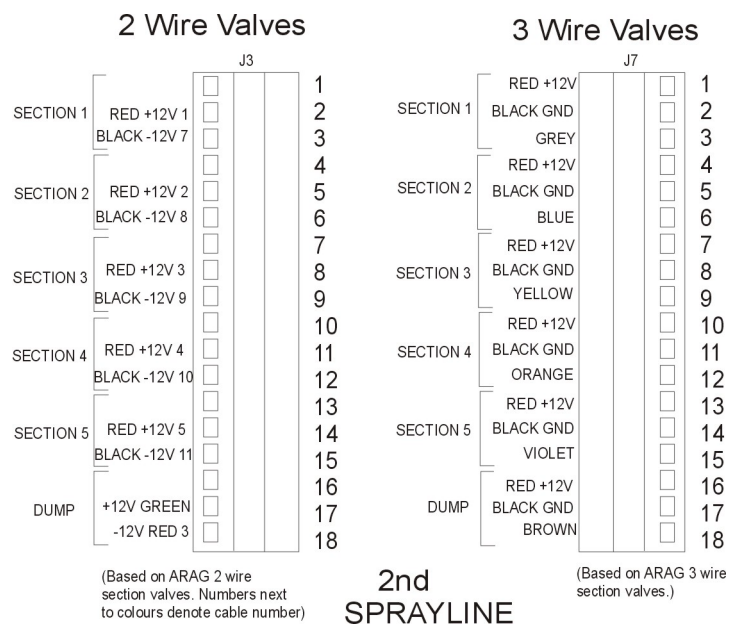

Pressure Sensor (Optional)

The pressure sensor measures spray line pressure at the section manifold to provide a pressure readout and to control the slow hold and second spray line functions (if used).

Using a mechanical pressure gauge fitted to the spray boom as a reference, the pressure sensor reading can be adjusted to compensate for line loss between the control bank and the spray boom.

AA-109	Pressure Sensor 0 - 600kpa/85psi
AA-109H	Pressure Sensor 0 - 40bar/600psi

See System Setup in Calibration section page 34.

Dump Valve (Optional)

The dump valve opens automatically whenever the sprayer stops or when all section valves are switched off. This option reduces reliance on the pressure relief valve to greatly reduce back pressure on a positive displacement pump.

The dump valve should be installed BEFORE the flow control valve.

Foam Marker Power

The four pin packard plug at the end of the sprayer loom connects to the AA-400/SBA foam marker compressor relay. This connects directly to the compressor and will supply power to the compressor any time the foam marker switch is set to the left or right position.

Foam Marker Solenoids

The utilux connectors labelled 'left' and 'right' at the end of the sprayer loom connect to the foam marker solenoids. When the foam marker switch is set to the left or right position the corresponding solenoids will switch on.

CONNECTIONS

A single loom connects the 24V1 to sensors and spray equipment. Connect the labelled connectors on the loom to their respective sensors (flow, wheel and pressure) or equipment (section valves and control valve). Connect power last after all installation is finished.

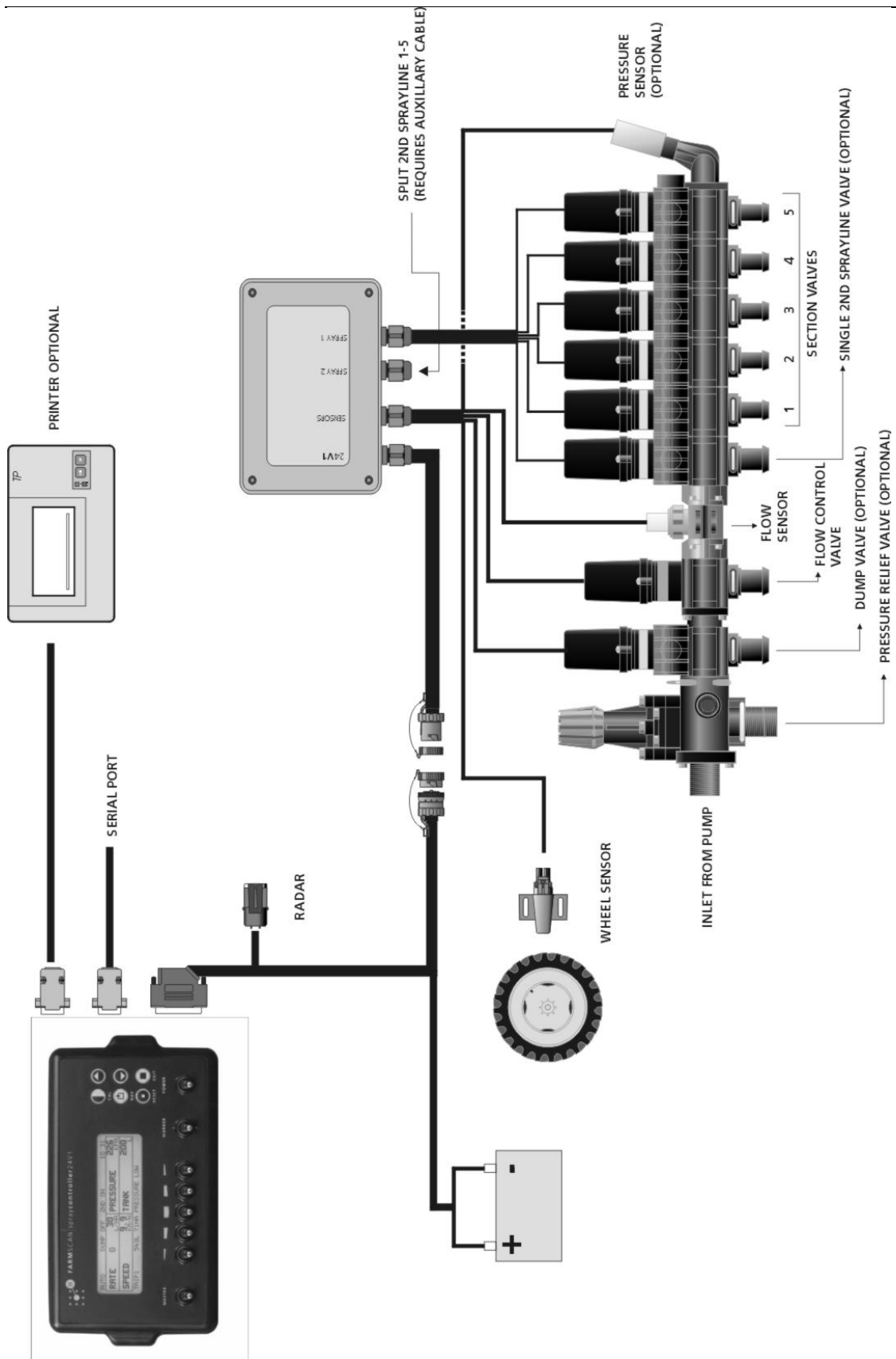

24V1/5-3UVC INSTALLATION

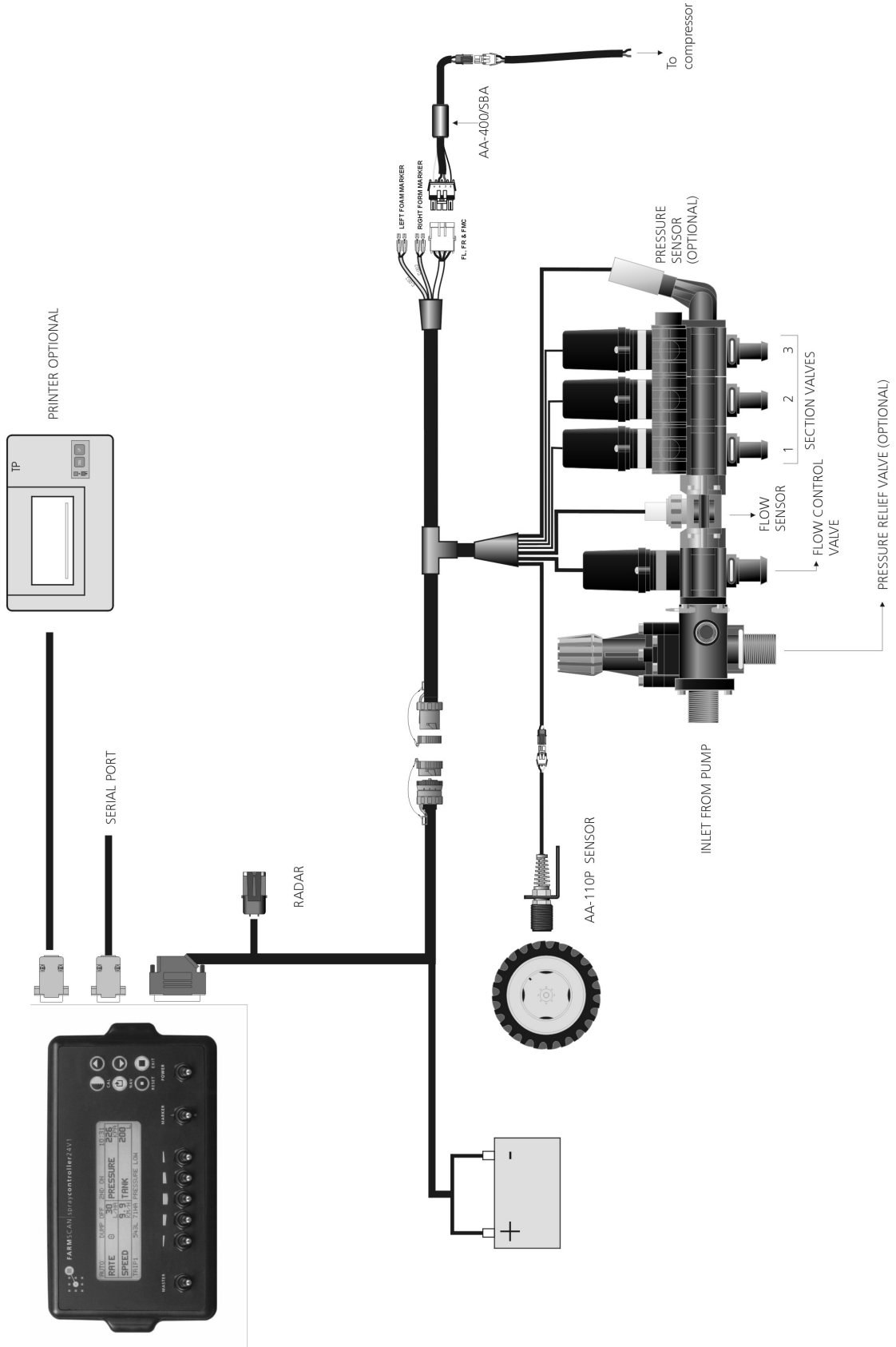

Connection To Power

There are two independent power cables in the loom system. The light duty cable feeds power to the spray controller in cab, the heavier cable powers the control valves.

The inline 10 amp blade fuse protects the heavy duty power cable.

The spray controller is reverse polarity protected and has an inbuilt resettable power cut out fuse.

Follow the guidelines below when connecting to power.

- Do not connect power until all other installation is finished.
- Connect **direct** to 12 Volt DC battery terminals, red wires to positive (+) and black wires to negative (-).
- Do not connect the power cable to a starter motor, alternator etc, as this may cause interference.
- Do not connect the power cable's negative direct to the chassis of the machine – it must be connected to the battery's negative terminal.
- Do not join other instruments off the controller power cable. Such as a two way radio.
- Use the provided cable ties to secure the power cable safely away from hot or moving parts.
- Connection to battery terminal bolts must be kept clean and tight. See the diagram below for typical battery connection schemes.

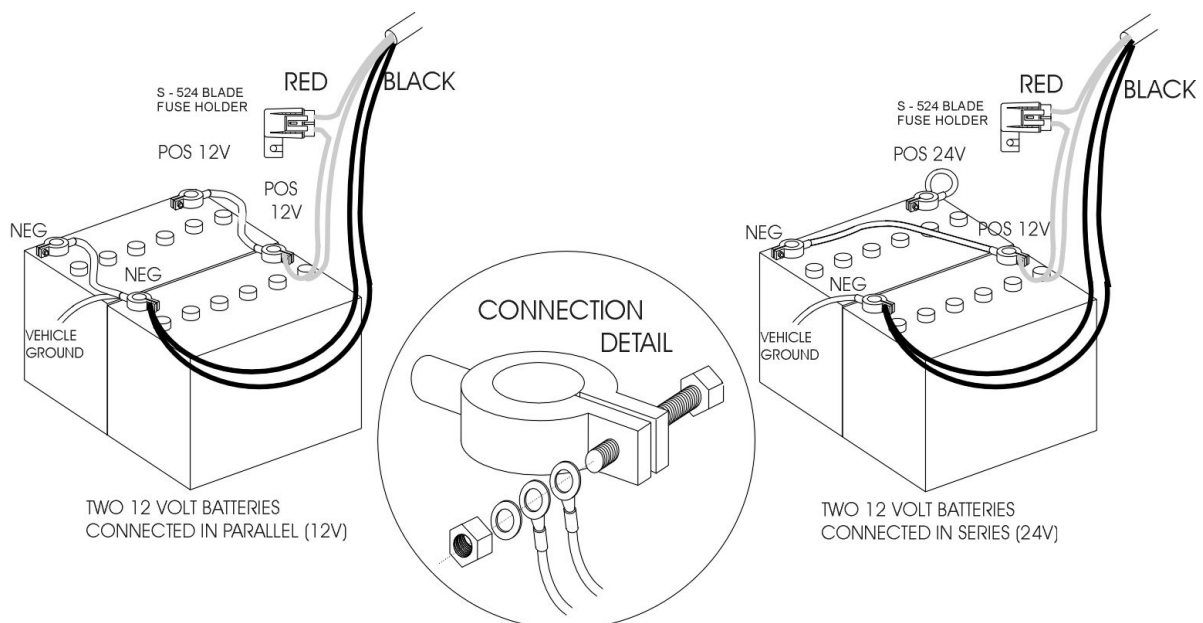

SPRAY CONTROLLER SYSTEM TEST

Before operating the spray controller, follow these steps with water in tank.

To correctly adjust the system pressure, you will require a good quality mechanical pressure gauge fitted either at the section manifold or ideally at the spray boom.

Test Procedure:

1. Ensure spray controller power cable is connected DIRECT to 12V DC battery supply.
2. Follow CALIBRATION instructions STEP 2 – OPTIONS.
3. EXIT to MAIN screen and use NAV key to highlight MODE icon at top left of main screen.
4. Press RESET key for 3 seconds until FLUSH mode is indicated.
5. Switch Master ON and all section valves ON, then start pump.
6. Press DOWN arrow key and spray pressure should reduce.
7. If spray pressure increases, then reverse wires to flow control valve.
8. Press UP button to increase pressure back to maximum available.
9. If first and second spray line used, press NAV key to highlight spray line status icons and use UP key to switch both lines ON.
10. Adjust pressure relief valve and pump revs to achieve 350-400kpa/51-58psi pressure on delivery side with all nozzles spraying.
11. Shutdown Master switch to check pressure relief and dump valve (if used) are functioning correctly.
12. Follow Calibration RATE and SETUP instructions to fully calibrate the controller.

OPERATION

24V1 FRONT PANEL

The 24V1 front panel consists of a screen, switches, function keys and indicator LEDs.

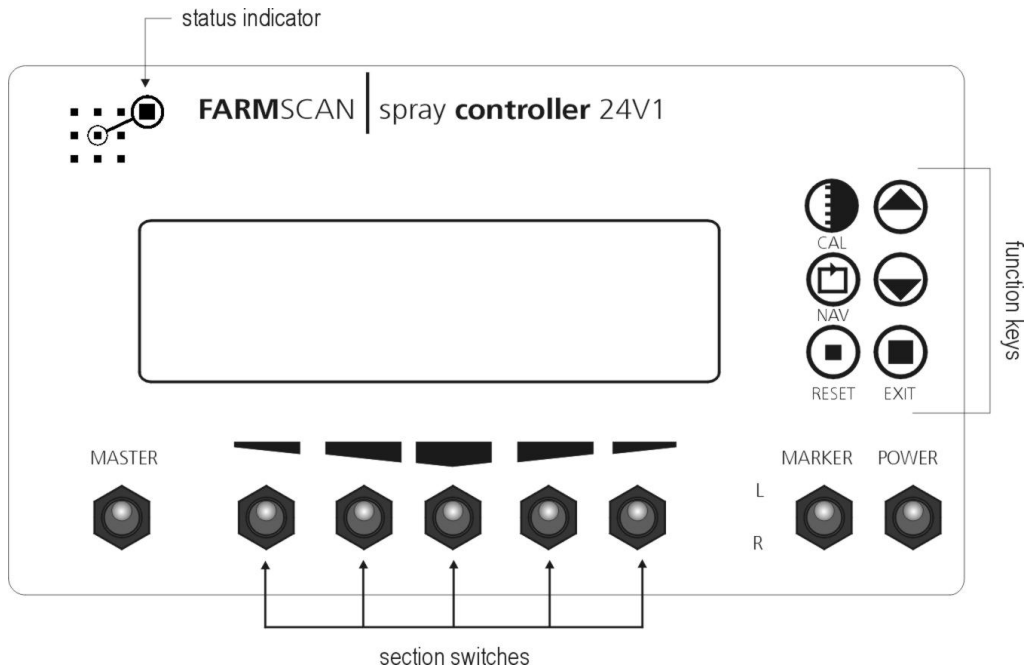

Status Indicator

The status indicator light gives visual indication of the spray controller operating condition.

'off'

The status indicator LED will be 'off' when the spray controller is 'on hold' (sprayer stationary or all sections off).

'green'

Indicates the spray controller is operating in AUTO mode and achieving the target rate, there are no alarm conditions.

'red'

Indicates the spray controller is operating in MANUAL mode, ie displaying the rate but not controlling.

'red flashing'

Indicates an active alarm condition, see message bar for details.

'amber'

Indicates the spray controller has established communication with an external guidance/task controller via the serial port.

Switches

Power

When the power is switched 'on', the spray controller starts with displaying the main operating screen and if stationary, will display the message "UNIT ON HOLD" and a short beep is repeated at 30 second intervals to remind the operator.

Master

The master switch provides overall control of the section switches, dump valve (if used) and flow control valve.

When master is switched 'off', the flow control valve holds the current pressure, the dump valve opens, all the section valves close and the spray controller goes into HOLD mode (ceases to accumulate area, distance or volume used).

For instant stop/start control of spray, the master should be switched 'off' or 'on' at working speed, thereby holding the working pressure at that point.

When master is switched 'on', the flow control valve resumes control and any section valves that are 'on' will open. When speed is greater than 0.5kph/mph, the spray controller goes 'off hold' and the dump valve closes.

Accumulation of area, distance and volume used resumes when master 'on' and at least one section valve is switched 'on'.

Sections

The section switches turn a section of the sprayer 'on' or 'off'. To activate a section flick the switch DOWN. If the split second line function is enabled, these switches will also operate sections of the second line.



Marker

The marker switch operates independently of the master switch, power switch must be 'on' for the marker switch to operate.

The marker switch has a centre 'off' position, allowing both left and right marker solenoids to be switched 'off'.

Flick the switch UP or DOWN to activate the left and right markers respectively.

Function Keys



Keys

The up and down arrow keys have three functions:

1. Increase/decrease the target spray rate.
2. Open/close the flow control valve when in 'Flush' mode or Manual mode.
3. Change calibration values in the calibration screens.



CAL Key

Used to:

- Enter the CALIBRATION MENU from the main screen.
- Enter calibration menus.
- Calculate calibration factors.
- Print trips.



NAV Key

Used to move the cursor around the screens to highlight a required function or display option.



EXIT key

Used to leave a calibration screen to return to the previous screen. The EXIT key works in all screens (flush screen) except the main screen.

To return to the main screen:

Press EXIT repeatedly until the main screen is displayed.



RESET Key

Used to:

- Clear accumulated TANK, DISTANCE or TRIP area/volume in the main screen.
- Clear total and trip data in the "RECORDS" screen.
- Reset calibration values when calibrating.
- Reset the target rate to the default/target value.
- Activate flush when stationary (hold for 3 seconds).

MAIN DISPLAY SCREEN

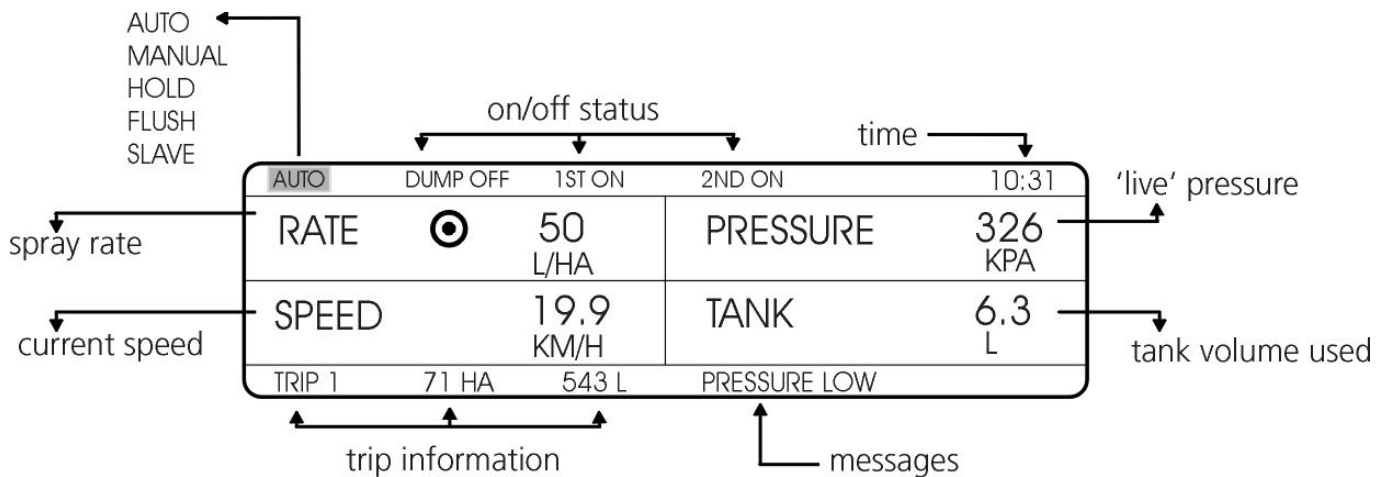

Display Settings

The LCD display contrast can be adjusted and the backlighting can be switched 'on' or 'off' or reversed for night working. See Calibration/DISPLAY OPTIONS page 38.

Display Options

The main display screen provides 4 primary information readouts that can be changed to suit the user preference.

See Calibration/DISPLAY OPTIONS section page 38.

The main display screen options are as follows:

1. **Application Rate** Live spray rate in L/ha (ga/ac), L/min (ga/min) or L/100m (row crops).
2. **Flow Rate** Live flow rate in litres per minute or gallons per minute.
3. **Pressure*** Live pressure at nozzles in kPa or psi.
4. **Speed** Live ground speed in km/h or mph.
5. **Area per Hour** Live work rate expressed as hectares/hour or acres/hour.
6. **Tank** Accumulated volume of tank used in litres or gallons.
7. **Area** Accumulated area covered in hectares or acres.
8. **Distance** Accumulated distance covered in kilometres or miles.

*requires optional pressure sensor.

If TANK, AREA or DISTANCE have been selected as a main screen display option, they can be reset at any time. Especially at the start of a new paddock/field and at the start of a full tank.

To reset Tank/Area/Distance:

1. Use the NAV key to highlight the TANK/AREA or DISTANCE display then press RESET key and the message "RESET TANK/AREA/DISTANCE?" will appear on the message bar.
2. Press the RESET key again to reset the display or press any other key to abort reset.

Time

A 24 hour clock displays the current time.

See Calibration/TIME & DATE page 38 to set time and date function.

Message Bar

The message bar provides warning information to the operator whenever the audible alarm is activated. When an alarm is active the status indicator LED will flash

A list of alarm messages is given below.

Message	Cause
"UNIT ON HOLD"	Speed is zero or all sections off or MASTER off.
"UNIT OFF HOLD"	Speed greater than zero, MASTER and section/s on.
"CHECK CALS"	Calibration settings are missing or incorrect.
"SLOW HOLD ACTIVE!"	Slow hold function has been activated
"PRESSURE HIGH"	Pressure is above high alarm point.
"PRESSURE LOW"	Pressure is below low alarm point.
"RATE HIGH"	Spray rate is above default target rate and the rate alarm %
"RATE LOW"	Spray rate is below default target rate and the rate alarm %
"TANK LOW"	Tank volume has dropped 10% of original volume

Alarm messages are cancelled when the condition has been rectified.

Mode Icon



The spray controller normally operates in AUTO or SLAVE mode and the operator selects FLUSH or HOLD as required.

The controller can be set for MANUAL operation through the RATES calibration menu.

- AUTO:** In AUTO mode the controller is ready to assume control of the rate and second spray line (if used) once ground speed is greater than 0.5kph/mph.
- MANUAL:** In MANUAL mode the application rate is controlled by manually adjusting the flow control valve using the up and down arrow keys.
- FLUSH:** FLUSH mode is used to clean or test the spraylines. Flush mode can be activated when the sprayer is stationary by pressing the RESET key for 3 seconds.
- SLAVE:** The SLAVE mode icon is activated when the spray controller establishes communication with an external device via the serial port.
- HOLD:** The HOLD icon is activated whenever speed is zero or the MASTER switch is OFF or all section switches are OFF.

Operating in AUTO mode

In AUTO mode the UP and DOWN arrow keys can be used to increase or decrease the target spray rate. The symbol alongside the rate display will indicate as follows:

-  Indicates current **rate** above default target rate.
-  Indicates current **rate** below default target rate.
-  Indicates current **rate** equals default target rate.

To start spraying:

1. Accelerate to working speed
2. Switch MASTER ON and at least one section. The spray controller will automatically begin spraying.

To change the target rate:

1. Use the NAV key to highlight the AUTO icon.
2. Press the UP or DOWN arrow key to view the current target rate or press RESET to instantly restore the set target rate.
3. Press the UP or DOWN keys again to increase or decrease the target rate in preset steps.

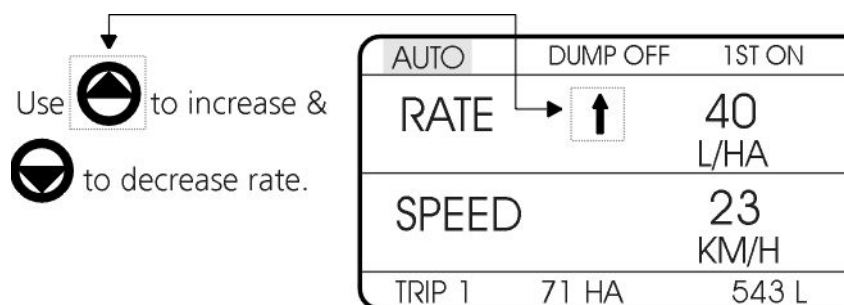

Example:

If the step size is 5 L/HA one UP arrow key press will display the target rate and the second press will increase the rate by 5 L/HA and one down arrow key press will decrease it by 5 L/HA.

See Calibration/RATE CALIBRATION page 29 to change STEP size.

To stop spraying:

Switch the MASTER OFF at a working speed to hold working pressure.

Operating in MANUAL mode.

In MANUAL mode the application rate is controlled by manually adjusting the flow control valve using the up and down arrow keys or in the event of a failed flow control valve, the rate can be set using the pressure relief valve set to a fixed operating pressure.

In manual mode the rate and pressure alarms are active, however the slow hold and 2nd line functions are **inactive**.

To activate MANUAL mode:

1. Press CAL key to enter CALIBRATION MENU.
2. Use NAV key to highlight the RATE menu and press CAL again.
3. Use NAV key to highlight MODE and use UP/DOWN keys to select MANUAL.
4. Press EXIT to return to main screen...Mode icon will indicate MANUAL.
5. Use NAV key to highlight MANUAL icon.
6. Switch MASTER ON and sections ON then use UP/DOWN keys or pressure relief valve to establish required operating pressure.
7. Drive at a fixed ground speed to achieve desired target rate.

Operating in FLUSH mode

The flush function is used to clean the spray lines or to test the nozzle operation. Flush can be activated at any time.

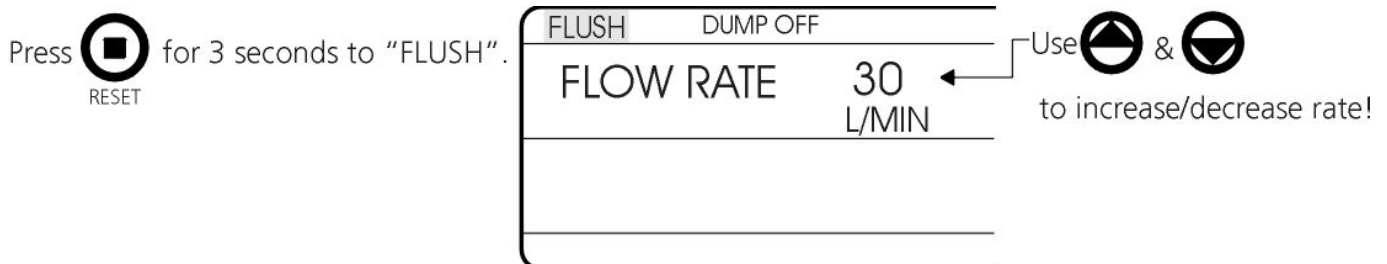

To activate FLUSH mode:

1. Exit to MAIN screen and use NAV key to highlight mode icon as shown above.
2. Press and hold RESET key for 3 seconds until FLUSH screen is displayed.
3. The mode icon will change to FLUSH, the flow control valve will go to full pressure, and the FLOW RATE, TANK and PRESSURE (if used) will be displayed.
4. Switch MASTER ON and use section switches to flush/test spray lines and nozzles.
5. Press the up or down keys to increase/decrease the flush rate if required.
6. Press EXIT or RESET key to return to MAIN screen after flushing.

To flush 1st or 2nd sprayline:

1. Go into FLUSH mode as explained above and use NAV key to highlight the 1ST or 2ND sprayline icon.
2. Use up/down keys to switch 1ST/2ND icon ON or OFF.

Operating in SLAVE mode

The spray controller will operate in SLAVE mode when connected to any guidance/task computer with compatible interface software.

Eg: Farmlap Professional 5200 and Farmlap Compact 5100 Guidance systems.

Target rates can be manually adjusted or the spray controller will automatically change rates if commanded by an external device and will report back on active section widths, actual rate applied, forward speed and pressure.

PRINT MENU		
PRINT	DISABLED	TRIP 1
SET CLOCK	11:49	12/7/02
SELECT PRINTER		

To operate in slave mode:

Ensure the guidance/task computer is fitted with compatible interface software.

1. Enter the PRINT MENU shown above.
2. Set field to the right of PRINT to DISABLED as shown above.
3. Press EXIT repeatedly to return to the main screen.
4. Switch the spray controller **off**.
5. Switch on the guidance/task computer and wait for it to start up fully.
6. Start up the guidance software, and get it ready for operation.
7. Use the optional Farmscan Serial Interface cable 5320 to connect from the spray controller serial port to the guidance/task computer serial port.
8. Switch the spray controller **on** and the status light will show 'amber' when serial communication is established.
9. The SLAVE mode icon will be displayed in the top left of the screen.

Note:

If communications is lost between the spray controller and the guidance/task computer then turn the 24V1 off and then on again to re-establish communications.

Records

The RECORDS MENU screen maintains a TOTAL of area sprayed and volume applied plus TRIP data for up to 10 separate paddocks/fields.

RECORDS MENU				
TRIP 1	101.4	HA	323	L
TOTAL	163.4	HA	408	L
			RESET ALL	PRINT

The TRIP function can be operated from the MAIN screen or from within the RECORDS MENU.

To access RECORDS MENU:

1. Press the CAL key.
2. Use the NAV key to highlight RECORDS in CALIBRATION Menu.
3. Press the CAL key to display RECORDS MENU.

To reset TOTAL and TRIP records:

1. Use the NAV key to highlight the TOTAL display.
2. Press the RESET key and the message RESET TOTAL? will appear.
3. Press the RESET key again or press any other key to abort the reset.
4. When you RESET the TOTAL, the message RESET ALL TRIPS? will appear.
5. Press the RESET key again or press any other key to abort the reset.

To view/select/reset TRIP 1-10:

1. Use the NAV key to highlight the TRIP icon.
2. Use the UP/DOWN key to view or select trip record 1-10.
3. Press the RESET key and the message RESET TRIP? will appear.
4. Press the RESET key again or press any other key to abort reset.

Note: Whichever TRIP 1-10 is displayed will be active when working.

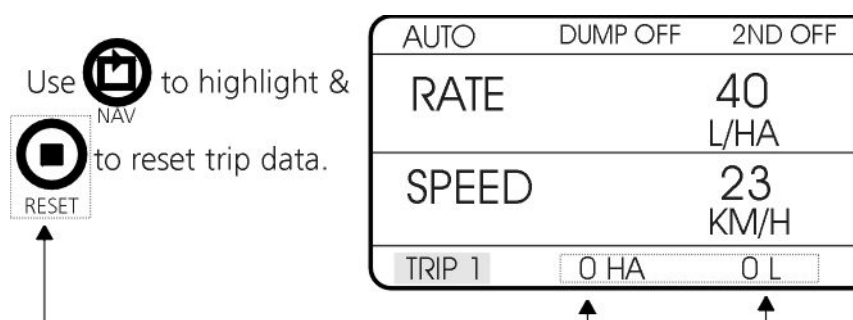

The Print Function (optional)

The spray controller will provide a hardcopy print-out of TOTAL and TRIP data using the optional Printer 2040 or an OEM printer connected to the serial port.

PRINT MENU		
PRINT	DEFAULT	TRIP 1
SET CLOCK	11:49	12/7/02
SELECT PRINTER		

To print records data:

1. Enter PRINT MENU as shown above.
2. Highlight the field to the right of PRINT and set to DEFAULT for the 2040 printer or OEM for another printer. DISABLED is used for SLAVE mode or when no printer is present.
3. Connect printer to serial port and ensure green light goes ON once SEL on printer is pressed.
4. Press the CAL key to enter the CALIBRATION MENU.
5. Use the NAV key to highlight RECORDS and press the CAL key again.
6. Use the NAV key to highlight the PRINT icon and press the CAL key to display the PRINT MENU.
7. In the PRINT MENU use the NAV key to highlight the ALL TRIPS or TRIP 1 field.
8. If printing one specific trip, use the UP and DOWN keys to select the required trip number (1-10).
9. When the right printing option is displayed press the CAL key to start the printer.

Stored data can be printed as many times as you like.

A sample of a trip print out is shown below:

FARMSCAN 24V1 SPRAY CONTROLLER

17:06 12/02/02

TRIP 1

12:20 12/02/02

----- TOTALS:

AREA 13.3HA
VOL 121.4L

TRIP 2

14:25 12/02/02

----- TOTALS:

AREA 22.3HA
VOL 462.4L

Slow Hold (Optional)

The slow hold function is used to avoid loss of spray coverage caused by loss of pressure when travelling too slow or when reducing the target rate below the recommended minimum for the nozzles.

Slow hold is an optional function that can be set to operate at a minimum speed equivalent to the minimum recommended pressure for a given target rate or if using the optional pressure sensor, the slow hold point can be set at a predetermined minimum pressure. Slow hold would normally be set to operate at 100-150kPa (15 – 22 psi).

Pressure based operation of slow hold provides the opportunity to vary rates and still maintain the slow hold function at a predefined minimum pressure.

When slow hold is activated, the message "SLOW HOLD ACTIVE!" will flash a warning on the message bar and the application rate display will flash to alert the operator.

WARNING: Operating with slow hold active will mean the product is being over applied and may cause damage to crop!

See Calibration/SYSTEM SETUP page 35.

Second Sprayline Operation (Optional)

A second spray line is activated automatically when the first spray line reaches a preset maximum pressure, thereby allowing higher operating speeds and additional capacity to change rates on-the-go.

See Installation Second Sprayline page ?? for more information.

*When using **speed based** activation* of the second spray line, refer to the nozzle suppliers chart to establish the speed at which the nozzles will reach maximum pressure for a given application rate. Normally that would be 300-350kpa (44 - 51 psi).

Eg: Spraying Systems 11002 nozzles operating at 60L/ha reach 300kPa @ 16km/h.

*When using **pressure based** activation*, you need to set both a minimum 'off' and maximum 'on' operating pressure. Normally that would be ON = 300-350kpa (44-51 psi), OFF = 100-150kPa (15-22 psi) for any size nozzle.

See Calibration/SYSTEM SETUP page 36.

Dump Function (optional)

The dump valve opens automatically when the sprayer stops or all sections have been turned off to dump all pump delivery back to tank.

The dump valve closes when MASTER is ON and at least one section valve is ON and speed is above 0.5km/h or 0.5mi/h.

The dump indicator displays the dump valve status, DUMP ON or DUMP OFF.

zero speed & "DUMP ON"

AUTO	▶DUMP ON	1ST OFF
RATE		0.0 L/HA
SPEED		0.0 KM/H
TRIP 1	71 HA	543 L

Note: The Dump option must be enabled from within the Calibration/OPTIONS see page 31.

Diagnosing Problems

The TEST MENU may assist in observing operation of the wheel, flow and pressure sensors.

TEST MENU			
WHEEL	0	FLOW	0
PRESSURE	0 KPA		

To test a sensor:

1. Press the CAL key and navigate to the DISPLAY menu.
2. Press CAL to open DISPLAY MENU 1, navigate to MORE and press CAL again.
3. Use the NAV key to highlight TEST and press CAL to open the TEST MENU.
4. Use the NAV key to highlight WHEEL, FLOW or PRESSURE (if used).
5. Press RESET to clear the pulse counter on display.

Note:

The test output for the wheel and flow sensors is an audible pulse count. While the test output for the pressure sensor is the raw kPa or psi output.

If driving over a set distance, the total wheel pulses should be nearly the same.

If filling a bucket, the flow sensor pulses generated should be nearly the same for a set quantity.

CALIBRATION - SETTING UP THE 24V1

Complete all installation (flow sensor, wheel sensor, pressure sensor, solenoid wiring, all connections including power) before setting up the 24V1.

This section of the manual provides a step by step setup guide. Following each step will setup the 24V1 for complete operation of all its functions. Optional steps can be skipped. Read the two sections "Screen Navigating" and "Before Starting – Metric Or Imperial" before following the step by step calibration guide.

Calibration Locking Function

The OPTIONS and SETUP menus can be locked preventing accidental tampering. When these menus are locked all calibration values can be viewed but not changed.

To lock/unlock SETUP and OPTIONS menus:

1. Press CAL to display the CALIBRATION MENU.
2. Use the NAV key to highlight SETUP menu.
3. Press and hold BOTH the up and down keys for 3 seconds.
4. The message "MENU OPTIONS LOCKED!" will appear.
5. Repeat steps 2 and 3 to unlock.

CALIBRATION MENU		
RATE	RECORDS	SETUP
OPTIONS	DISPLAY	ALARMS
VERSION: 1.0.0		MENU OPTIONS LOCKED!

Screen Navigating

Entering the CALIBRATION MENU:

While in the main screen press the CAL key. The CALIBRATION MENU shown below will be displayed.

CALIBRATION MENU		
RATE	RECORDS	SETUP
OPTIONS	DISPLAY	ALARMS
VERSION: 1.0.0		

The spray controller software version number is shown at bottom left of screen.

Exiting calibration menus:

Press the EXIT key to leave a calibration menu and return to the previous screen. Pressing EXIT repeatedly will return you to the main screen.

Selecting calibration menus:

Use the NAV key to highlight a CALIBRATION MENU item then press CAL to open a menu item.

Changing calibration settings or options:

Use the NAV key to highlight a value. Follow calibration instructions at bottom of screen and use the up and down arrow keys to change the value.

Saving calibration settings:

Upon pressing the EXIT key and leaving the present screen settings will be saved.

Before Starting - Metric or Imperial

If you prefer to calibrate the spray controller using Imperial units, this must be set before starting calibration otherwise proceed to STEP 1.

To select Metric or Imperial:

1. Press CAL to enter the CALIBRATION MENU.
2. Use NAV key to highlight OPTIONS then press CAL to open OPTIONS MENU 1.
3. Press CAL again at the MORE prompt until OPTIONS MENU 4 is displayed.

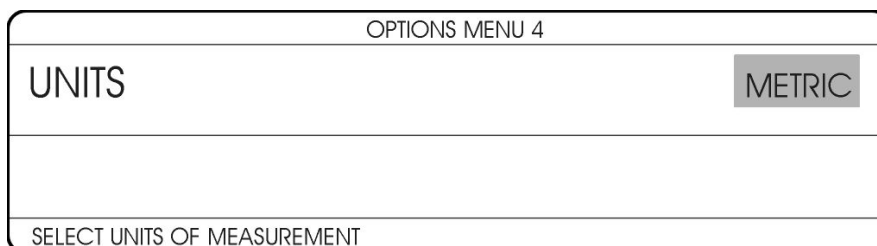

4. Use the up or down arrows to select Imperial or metric units.
5. Press EXIT key repeatedly until returned to the main screen.

STEP 1- RATE CALIBRATION

Press CAL to enter the CALIBRATION MENU then use NAV key to highlight the RATE menu item and press CAL to open the RATE MENU.

RATE MENU		
RATE	25L/HA	STEPSIZE ↑↓ 10 L/HA
MODE	AUTO	
ENTER DEFAULT TARGET RATE		

Rate

The default target rate is the normal spray rate for a particular product or job.

To set rate:

1. Use the NAV key to highlight the RATE calibration.
2. Use the up/down arrow keys to set the default target rate.

Step Size

When operating, the default target rate can be increased or decreased in predefined steps.

To set step size:

1. Use the NAV key to highlight the step size calibration setting.
2. Use the up/down arrow keys to set the amount of rate increase/decrease per step.

Eg: 5L/ha will allow an increase or decrease in 5L/ha steps.

Note: Set 0L/ha to prevent the rate from being altered.

Mode

The operating mode can be selected as AUTO or MANUAL. The normal default mode is AUTO.

To select the mode:

1. Use NAV key to highlight MODE.
2. Use up/down to select AUTO or MANUAL.
3. Press EXIT key to return to main screen.

STEP 2 – OPTIONS

The OPTIONS menu screens are used to enable advanced sensor and control options that will determine the availability of other calibration settings in the SETUP menu.

In the CALIBRATION MENU highlight OPTIONS and press CAL to open OPTIONS MENU 1.

OPTIONS MENU 1	
PRESSURE	600 KPA
RADAR INTERFACE	DISABLED
NEXT MENU	MORE

Pressure

If using a pressure sensor, the type of pressure sensor being used must be selected.

To select pressure sensor:

1. Use NAV key to highlight PRESSURE then use UP or DOWN key to select 600kpa 40 bar pressure sensor.

Note: Pressure should be DISABLED if no pressure sensor is connected.

Radar Interface

If using a radar speed sensor then RADAR INTERFACE must be ENABLED.

To enable radar interface:

1. Navigate to Radar Interface and use UP/DOWN to select ENABLED or DISABLED.
2. Navigate to MORE and press CAL to open OPTIONS MENU 2.

Second Spray line (Optional)

If a second spray line is used, select Full or Split second spray line.

A Full second line has only one valve to control the second spray line.

A Split second line has multiple section valves to control the second spray line.

OPTIONS MENU 2	
SECOND LINE	SPLIT LINE
SECOND LINE MODE	MULTI STEP
NEXT MENU	MORE

To select second sprayline:

1. Use NAV key to highlight the SECOND LINE option.
2. Use the up/down key to choose FULL or SPLIT second line.

Note: If second spray line not used, select DISABLED and proceed to MORE options.

Second Line Mode

If a pressure sensor option is used, the second line mode has the choice of SINGLE STEP or MULTI STEP control. If no pressure sensor is used the default setting is SINGLE STEP control.

Single Step:

The second spray line is turned on after a speed (kph) or pressure (kpa) activation point has been passed. Once the system speed or pressure drops below the activation point then the second line shuts off.

Multi Step:

The first and second spray lines are controlled in a stepped sequence. See Installation page 10.

When the second line ON pressure is reached, the first line is switched off and the second line is switched on.

When the second line reaches the ON pressure, then BOTH the first and second spray lines are switched ON.

The second spray line must be fitted with nozzles one size larger than the first spray line nozzles.

To set second line mode:

1. Use NAV key to highlight SECOND LINE MODE then use UP/DOWN keys to select SINGLE STEP or MULTI STEP control.
2. Navigate to MORE and press CAL to open OPTIONS MENU 3.

Dump (Optional)

If a dump valve is used to divert pump delivery back to tank when stopped or master OFF, the DUMP option must be ENABLED.

Note: Dump option should be DISABLED if not used.

OPTIONS MENU 3	
DUMP	ENABLED
VALVE TIME	5 SEC
NEXT MENU	MORE

Navigate to DUMP option and use up/down keys to select ENABLED or DISABLED.

Valve Time

The VALVE TIME option controls the responsiveness of the flow control valve.

The default for this setting is 5. This value can be changed to fine tune the response of the control valve. If the control valve tends to overshoot the target rate, reduce this number. If the control valve tends to undershoot (too slow) increase this number.

To adjust valve time:

1. Navigate to "VALVE TIME" and use up/down keys to adjust response.
2. Press "EXIT" key repeatedly to return to "CALIBRATION MENU".

STEP 3 – SYSTEM SETUP

System setup is the area where calibration factors that determine the operating parameters are setup.

In the CALIBRATION MENU highlight SETUP and press CAL to open SETUP MENU 1.

SETUP MENU 1			
FLOW	638.8 PPL	WHEEL	0.815 M
PRESSURE	-25 KPA	T-WIDTH	10.00 M
NEXT MENU			MORE

Calibrate WHEEL Factor

The wheel factor is used by the controller to calculate ground speed. The wheel sensor/radar/speedo sensor/tailshaft sensor or GPS speed sensor generates speed pulses at set distance intervals.

The distance travelled between pulses is known as the Wheel factor which must be correctly entered into the controller. Follow the instructions below to calculate the wheel factor:

1. Enter the SETUP MENU 1 screen.
2. Use the NAV key to highlight the WHEEL factor and press CAL to open the WHEEL SENSOR CAL screen.

WHEEL SENSOR CAL			
WHEEL			0.00 M
PULSES	0	DISTANCE	0.00 M
DRIVE A DISTANCE TO START TEST			

To calibrate the wheel sensor:

1. Measurement procedure must be performed in working conditions, not on a sealed road (recheck measurement when moving from hard to soft working conditions).
2. Creep vehicle forward and stop exactly on a pulse count, then press RESET key to zero the PULSES reading.
3. Peg ground at bottom centre of any wheel as a starting point for measurement.
4. Drive forward in a straight line for a reasonable distance (25m or 82 feet or more) and stop exactly in a pulse update. If you miss a pulse go to the next one, do not reverse!
5. Measure the exact distance travelled from the starting peg to the centre of the same tyre.
6. Navigate to DISTANCE setting and use up/down keys to enter the measured distance (do not reset the pulse count!).
7. Press CAL key to auto divide pulses and distance to update the wheel factor.

Eg: 28.52m travel divided by 35 pulses = 0.815m wheel factor.
93.54 feet travel divided by 35 pulses = 2.67 feet wheel factor.

Note:

Repeat the measurement to verify accuracy.

Calibrate SECTION WIDTHS

Follow the procedure below to enter the boom section widths into the 24V1.

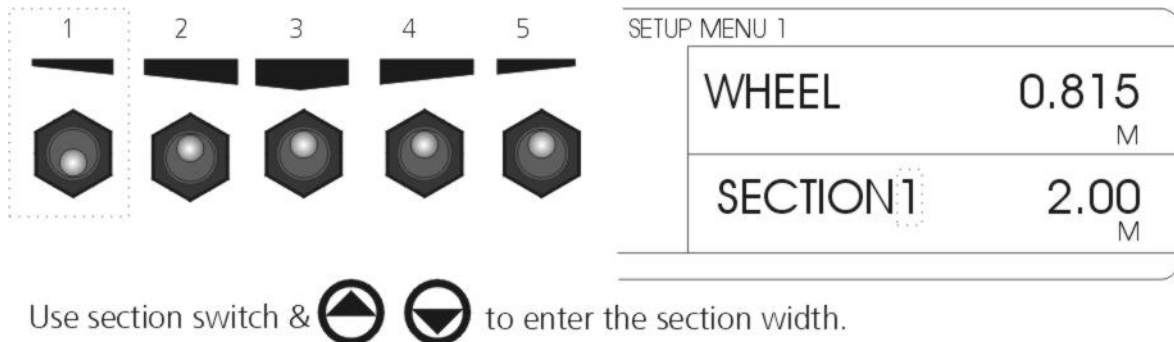

1. Use NAV key to highlight the WIDTH calibration setting.
2. Turn off all section switches and leave MASTER switch ON = WIDTH OFF.
3. Switch **on** one section at a time to display the SECTION width.
4. Use the up and down arrow keys to enter the displayed section width.
5. Turn off that section and turn on another section.
6. Enter the width of the next section and repeat steps 4 and 5 until all the section widths have been entered.
7. When all the section widths have been entered, switch all the sections **on** to display the correct total width T-WIDTH.

Note: When calculating effective section width, multiply the number of nozzles on a section by the nozzle spacing when spacings are equal.

Important: If any section switches are not used, set each unused SECTION width to ZERO.

Calibrate FLOW SENSOR

The flow sensor calibration factor relates to the number of pulses per litre/gallon (PPL/PPG) generated by the flow sensor. The pulse factor is unique to every flow sensor and will vary slightly depending on liquid viscosity and plumbing configuration.

Even though on the tag attached to the flow sensor included in the kit has a base calibration factor, this factor should be checked.

To check the flow cal factor:

1. Enter the SETUP MENU 1 screen.
2. Use the "NAV" key to highlight the FLOW calibration factor and press CAL to open the FLOW SENSOR CAL screen.

FLOW SENSOR CAL			
FLOW			638.8 PPL
PULSES	0	VOLUME	0.00 L
ACTIVATE SECTION SWITCH TO START TEST			

3. Direct a hose from one section valve into a 20L / 5 gallon calibration bucket.
4. Switch the Master and section valve **on** to prime the hose, then shut off.
5. Press RESET key to clear the PULSES back to **zero** and empty bucket.
6. With hose in bucket, switch the Master and section valve on to start the test. Switch off the section at a known volume or measure the volume.
7. Navigate to VOLUME and use the up/down keys to enter the measured volume.
8. Press CAL to auto divide the pulses to volume and update the FLOW CAL.
9. Press EXIT to return to the main screen.

Note: If the calculated FLOW CAL differs greatly from the sensor cal tag, repeat the test.

Calibrate PRESSURE SENSOR

If a pressure sensor is installed at the flow control bank, a pressure calibration must be entered to offset the pressure loss from the location of the pressure sensor to the nozzles.

Follow the calibration procedure given below.

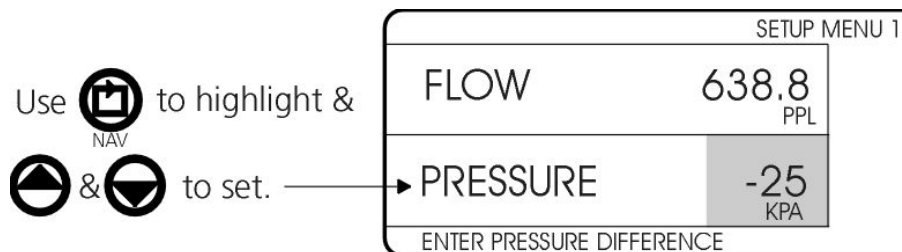

1. Install an accurate mechanical pressure gauge on the spray boom.
2. Exit to the main screen and press RESET key for 3 seconds to enter FLUSH mode.
3. Switch the MASTER **on** and a section switch corresponding to the mechanical gauge.
4. Use the down key to adjust the mechanical gauge pressure to 300kPa/44.5psi
5. Take note of the spray controller pressure reading. Eg 325kpa.
6. Subtract the mechanical gauge reading from the spray controller reading. Eg 325kpa -300kpa = 25kpa difference.
7. Navigate to SETUP MENU 1 and highlight the PRESSURE calibration setting.
8. Use the up/down keys to enter the pressure difference.
9. Navigate to MORE and press CAL to open SETUP MENU 2.

Calibrate Slow Hold Point

The slow hold function is used to avoid loss of spray coverage caused by loss of pressure when travelling too slow or when reducing the target rate below the recommended minimum for the nozzles.

Slow hold is an optional function that can be set to operate at a minimum speed equivalent to the minimum recommended pressure for a given target rate (speed based) or if using the optional pressure sensor, the slow hold point can be set at a predetermined minimum pressure (pressure based).

Slow hold would normally be set to operate at 100-150kpa (15 –22 psi)

SETUP MENU 2			
SLOW HOLD		50 KPA	
2ND LINE ON:	350 KPA	OFF:	150 KPA
ENTER SLOW HOLD PRESSURE			

To calibrate speed based slow hold:

If the pressure sensor option is not used, then the slow hold function will be speed based.

1. Exit to the MAIN screen and start spraying in AUTO mode at normal speed then slow down until nozzle pattern begins to deteriorate.
2. Take note of the ground speed when this happens and use this point for slow hold speed calibration.
3. Navigate to SETUP MENU 2 and highlight the SLOW HOLD calibration setting.
4. Use the UP and DOWN keys to set the desired hold speed (kph/mph).

Note: To switch the SLOW HOLD function OFF, hold the DOWN key until OFF is displayed.

To calibrate pressure based slow hold.

If a pressure sensor option is used, then the slow hold function will be pressure based.

Generally the slow hold pressure would be set at 100-150kpa/ 15 – 22psi

1. Navigate to SETUP MENU 2 and highlight the SLOW HOLD calibration setting.
2. Use the UP and DOWN keys to set the desired hold pressure (kpa/psi).

Note: To switch the SLOW HOLD function OFF, hold the DOWN key until OFF is displayed.

WARNING: Operating with slow hold active will mean the product is being over applied and may cause damage to crop!

Calibrate Second Spray line

To calibrate speed based second spray line:

If the pressure sensor option is not used, the second spray line will use speed based operation.

1. Navigate to SETUP MENU 2 and highlight SECOND SPRAYLINE calibration speed.
2. Refer to nozzle manufacturers spray chart and establish the speed at which the first sprayline nozzles will reach maximum pressure for a given application rate. Normally that would be 300-350kpa (44 – 51 psi).

Eg: Spraying Systems 11002 nozzles operating at 50L/ha reach 300kpa @ 16km/h.

3. Use UP/DOWN keys to set SECOND SPRAYLINE calibration speed (kph/mpH).

To calibrate pressure based second sprayline:

If the using a pressure sensor, the second sprayline will use pressure based operation.

With pressure based operation, there is a requirement to set both an ON pressure and an OFF pressure for second spray line operation.

1. Navigate to SETUP MENU 3 and highlight the Second Sprayline ON point calibration.
2. Use the UP/DOWN keys to set the ON pressure at 300kpa/44psi or higher.
3. Navigate to the Second Spray line OFF pressure and set to 100kpa/15psi.
4. Press the EXIT key repeatedly to return to the CALIBRATION MENU.

Note:

If using a single step second spray line with nozzles the same size as the first spray line nozzles, then the OFF pressure must be less than half the ON pressure.

STEP 4 - ALARMS

The spray controller has three user settable alarms.

When an alarm condition occurs, status light will flash red, the related information display will flash and a warning message will appear on the message bar. For example, TANK in the main screen will flash when a tank low alarm is displayed.

ALARMS MENU			
TANK	500 L	RATE ±	10 %
PRESS LO	100 KPA	PRESS HI	350 KPA

Tank Alarm

The tank alarm function will alert the operator when 90% of the preset tank volume has been used.

To calibrate Tank alarm"

1. Press CAL key to open the CALIBRATION menu.
2. Use the NAV key to highlight the ALARMS MENU then press CAL.
3. Use the NAV key to highlight TANK calibration.
4. Use the UP/DOWN keys to set the full Tank Capacity.

Rate Alarm

An alarm is raised if the application rate can not be controlled to within the percentage amount set in the rate +/- calibration.

To set rate alarm:

1. Use the NAV key to highlight RATE +/- calibration.
2. Use the UP/DOWN keys to set the allowable % variation (5% recommended).

Pressure Alarm

If a pressure sensor is installed, the pressure high and low alarm points can be set.

An alarm is raised when the system pressure exceeds either one of the pressure alarm points. Upon receiving a pressure alarm message the operator must increase or decrease speed to rectify the pressure alarm.

To set pressure alarm:

1. Use the NAV key to highlight Pressure LO calibration.
2. Use the UP/DOWN keys to set the LO Pressure limit. (100kpa/??psi recommended) (0kpa/psi recommended if slow hold feature active).
3. Use NAV key to highlight Pressure Hi calibration. (Greater than 350kpa/51psi recommended)
4. Press EXIT key to return to MAIN screen.

Note: To eliminate pressure HI or LO alarm points set to ZERO.

Sound

The sound level can be set to one of three levels: HIGH, LOW and OFF.

ALARMS MENU 2		
SOUND	HIGH	
SELECT SOUND VOLUME		

To set sound volume:

1. Enter ALARMS MENU 2
2. Use the up and down keys to select the sound setting.

STEP 5 TIME & DATE

Time and date are set in the RECORDS MENU.

PRINT MENU		
PRINT	DEFAULT	TRIP 1
SET CLOCK	11:49	12/7/02
HIT CAL KEY TO PRINT TRIP		

1. Press CAL to open the CALIBRATION MENU.
2. Use NAV key to highlight the RECORDS menu and press CAL.
3. Use NAV key to highlight the PRINT menu and press CAL.
4. Use NAV key to highlight the HOUR/MINUTES/DAY/MONTH and YEAR fields.
5. Use the UP/DOWN keys to set the time and date.
6. Use the EXIT key to return to the MAIN screen and the time as set will appear on the top right of the screen.

Note: Set time as 24 hour clock. ie 3.30pm is 15:30.

STEP 6 DISPLAY OPTIONS

The MAIN display screen provides 4 primary information readouts that can be changed to suit the user preference.

The top left display selection can be set to application rate (RATE) or FLOW RATE only.

The remaining three display quadrants can be set to any other display option.

DISPLAY MENU 1			
RATE	L/HA	PRESSURE	KPA
SPEED	KM/H	TANK	L
			MORE

The diagram below shows the display options available.

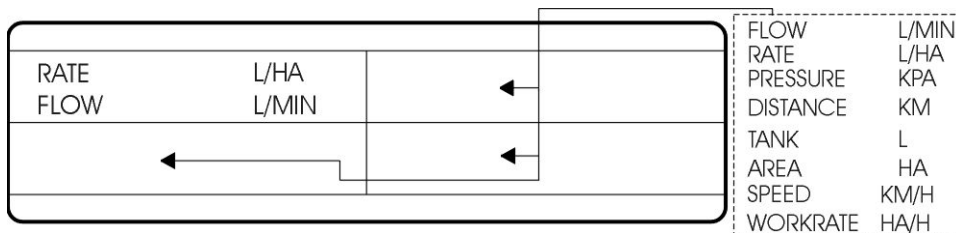

To change display options:

1. Press CAL key to open Calibration MENU.
2. Use Nav key to highlight the DISPLAY MENU and press CAL.
3. Navigate to highlight any of the 4 display quadrants.
4. Use the UP/DOWN keys to view display options in each quadrant.
5. Navigate to another quadrant to set another display option.
6. Press EXIT key to return to MAIN screen.

Note: Each display options can only be selected in one quadrant.

Display Settings

The LCD display contrast can be adjusted and the backlighting can be switched 'on' or 'off' or reversed for night working.

DISPLAY MENU 2			
CONTRAST	59	DISP	INVERT
BACKLIGHT	OFF	SHOW	TEST

To invert display:

Highlight DISP and use the up or down key to change INVERT to NORMAL or vice versa. The INVERT setting will darken all the background pixels and make the text pixels light.

To turn on the backlighting

Highlight BACKLIGHT and use the up or down key to change ON to OFF or vice versa.

Having the backlighting on is useful for night spraying.

SAMPLE SETUP

Shown below are the calibration screens for a system setup with a 600kPa pressure sensor, a split second line, a dump valve, Arag control valve (typical valve time 6 seconds), pressure activated second line, pressure activated slow hold, pressure, rate and tank alarms, target rate set to 25L/Ha and metric units.

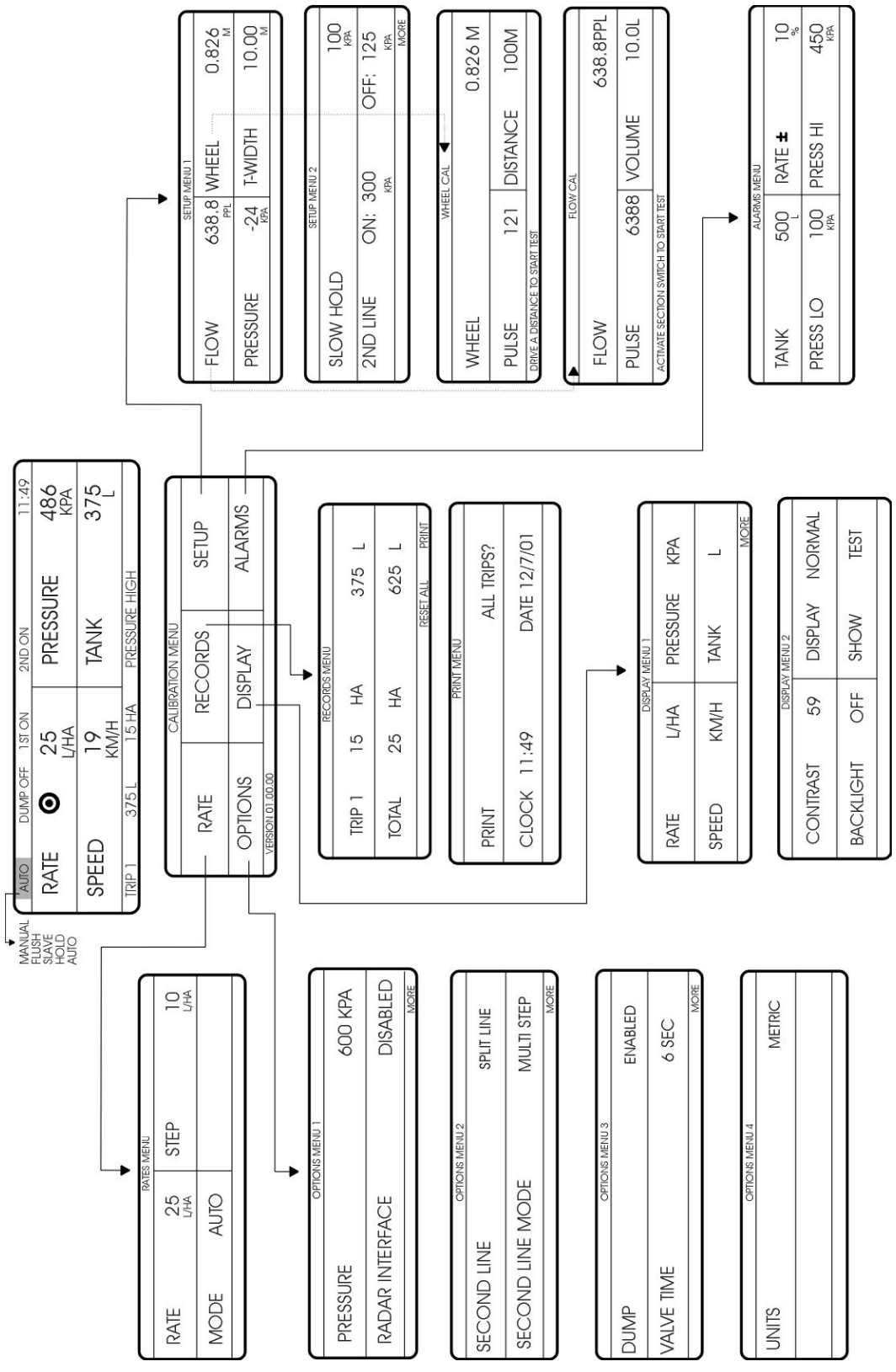

PIN OUTS

24V1 - 25 way Connector Pin Out (control Interface)

Pin	Description
1	GND
2	+ 12 Volts OUT
3	SECTION 1
4	SECTION 2
5	SECTION 3
6	SECTION 4
7	SECTION 5
8	MARKER RIGHT
9	FLOW
10	PRESSURE
11	MOTOR 3
12	MOTOR 2
13	MOTOR 1
14	GND
15	+12 Volts OUT
16	DUMP
17	SPARE 3
18	SPARE 2
19	SPARE 1
20	MARKER LEFT
21	SPRAY 2 (2 nd line)
22	WHEEL
23	MOTOR 4
24	MOTOR 2
25	MOTOR 1

24V1 - 9 way DB Connector Pin Out (RS485 comm's Interface)

Pin	Description
1	+ 12 Volts IN
2	RS + 485
3	RS - 485
4	GND
5	GND
6	+ 12 Volts IN
7	
8	
9	+ 12 Volts OUT

L/100M - SETTING UP FOR HORTICULTURAL ROW SPRAYING

The 'L/100m' setting applies the target quantity of litres every 100m of row crop. For a two or row three sprayer, the 'L/100m' setting will apply the same target quantity of litres for every row that the sprayer can spray. For example, the 'L/100m' target rate is 10L/100m, and you have a 2 row sprayer, for every hundred metres 10L will be sprayed on both rows. In total 20L will be sprayed every 100m.

Follow the step by step guide below to set up the 24V1 for horticultural row spraying.

Step 1 - Display 'L/100m'

1. Press CAL key to open Calibration MENU.
2. Use NAV key to highlight the DISPLAY MENU and press CAL.
3. Navigate to highlight RATE.
4. Use the UP/DOWN keys to change to 'L/100M'.
5. Press EXIT key twice to return to main screen. Check main screen rate is in 'L/100M'.

Step 2 - Set Target Rate

1. Press CAL key to open Calibration MENU.
2. Use NAV key to highlight the RATE MENU and press CAL.
3. Navigate to highlight TARGET.
4. Use the UP/DOWN keys to set the target rate.
5. Use NAV key to highlight STEPS and use UP/DOWN keys to set step size.
6. Press EXIT key to return to Calibration MENU.

Step 3 - Set Up Section Widths

1. Use Nav key to highlight SETUP MENU and press CAL.
2. Use NAV key to highlight SPACING and press CAL.

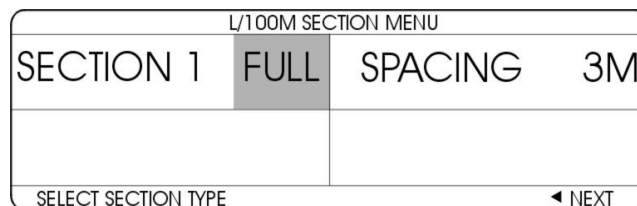

3. Switch on MASTER and switch off all sections.
4. Use NAV key to highlight the top left quadrant (displaying OFF).
5. Switch on 1st section **only** and use UP/DOWN keys to select the portion of a row the first section sprays ie half or full. See below.

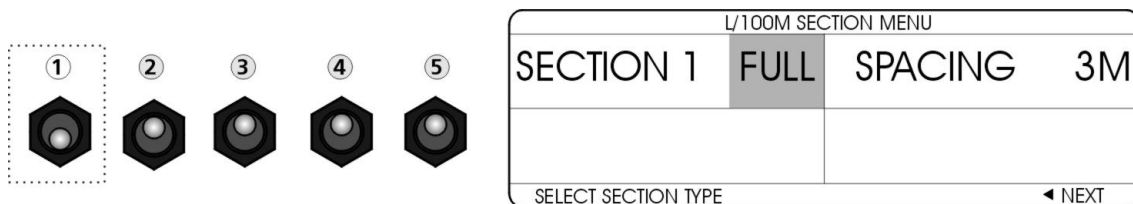

Use section switch &   to select HALF or FULL.

Note: Select HALF or FULL for one section at a time!

6. Switch off 1st section and switch on 2nd section. Use UP/DOWN keys to select portion of row the second sections sprays (half or full).
7. Repeat step 6 for the remaining sections if required (ie. for 3 or 4 sections). See examples below for clarification.

single row sprayer (2 sections)

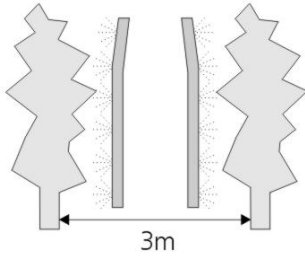

For **2** sections set:
 SECTION 1 **HALF**
 SECTION 2 **HALF**

2 row sprayer (2 or 4 sections)

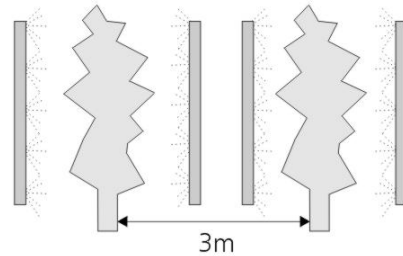

For **2** sections set:
 SECTION 1 **FULL**
 SECTION 2 **FULL**

For **4** sections set:
 SECTION 1 **HALF**
 SECTION 2 **HALF**
 SECTION 3 **HALF**
 SECTION 4 **HALF**

2 row sprayer (3 or 4 sections)

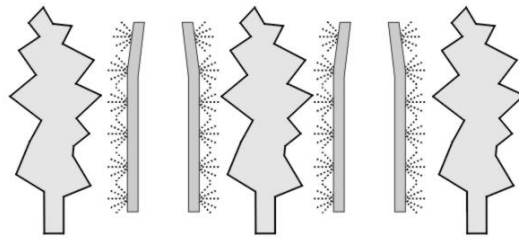

For **4** sections set:
 SECTION 1 **HALF**
 SECTION 2 **HALF**
 SECTION 3 **HALF**
 SECTION 4 **HALF**

For **3** sections set:
 SECTION 1 **HALF**
 SECTION 2 **FULL**
 SECTION 3 **HALF**

3 row sprayer (3 sections)

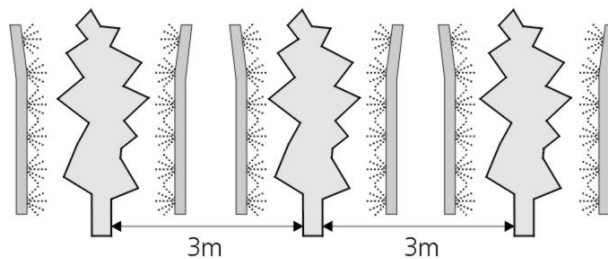

Set:
 SECTION 1 **FULL**
 SECTION 2 **FULL**
 SECTION 3 **FULL**

Note:

HALF and FULL represent half a row sprayed and a full row sprayed.

Step 3 continued...

- After setting up all the sections steps 3 to 7. Switch on all the sections being used (1- 4) and check that the total number of rows being sprayed is correct.

For the 3 row sprayer example on the previous page, when all three sections are switched on ROWS 3 will be displayed. See below.

When all sections on total rows being sprayed is displayed.

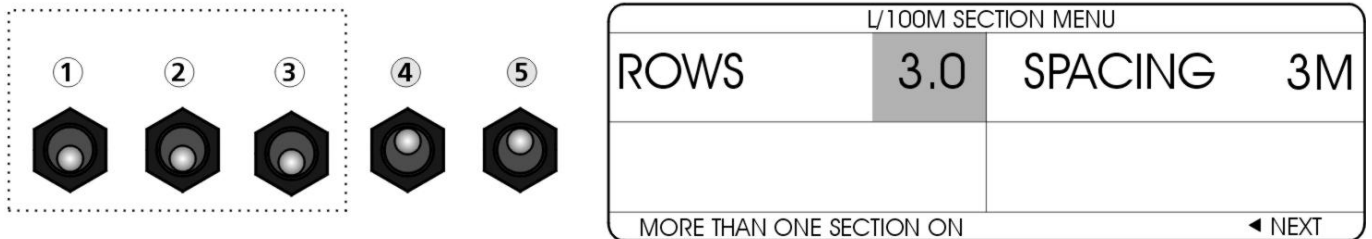

All 3 sections were set to FULL (1 row). When all sections on 3 rows is displayed.

- Use NAV to highlight SPACING. Use UP/DOWN key to enter row spacing.

Note:

SPACING is the distance between rows and is used to calculate area sprayed.

- Use EXIT key to return to main screen. Rate in L/100M should be displayed see below.

AUTO		1ST ON		10:31	
RATE	⊙	12	PRESSURE	326	
		L/100M		KPA	
SPEED		6.9	TANK	6.3	
		KM/H		L	
TRIP 1	71 HA	543 L	PRESSURE LOW		

TROUBLESHOOTING

Use the following guide to troubleshoot problems with the 24V1 spray control system. If the problem can not be remedied contact the Farmscan service department on +61 8 9470 1177 (fax: +61 8 9470 2855) or via email: service@farmscan.com.

PROBLEM		Possible cause/remedy	
1.	CONTROLLER DOES NOT TURN ON.	a.)	10 Amp fuse on loom has blown.
		b.)	Internal poly fuses have blown. Disconnect controller from power and wait. After poly fuses reset connect power again and turn on. If not repeat and wait longer.
		c.)	Check that connections to battery are clean and tight. Try again with the engine running.
		d.)	Check that red wire is to positive (+) and black is to negative (-).
		f.)	Check that no other device is connected to the same power cable. The power cable must be completely independent.
2.	SPEED READOUT TOO FAST OR TOO SLOW.	a.)	Incorrect wheel calibration factor. Repeat wheel calibration procedure.
3.	SPEED READOUT JUMPY.	a.)	Make sure magnet is facing sensor correctly as shown in "Wheel Sensor Installation". Use of an alternative magnet may cause problems due to wrong orientation of magnet.
		b.)	Check that wheel magnet is present and the magnet is 10 - 15 mm away from wheel sensor as they pass. Magnet too close can cause jumpy speed.
		c.)	If the readout is jumpy, it indicates that the pulses from the wheel sensor are inconsistent. Check for poor or intermittent connections to sensor. Check sensor cable for physical damage, making sure cable has not rubbed through to the chassis due to sharp edges.
		d.)	If fault can not be found, enter "TEST MENU". Drive slowly forward and listen to the beeps. The sound should be rhythmic at a fixed speed. If the sound is jumpy, and wiring is OK, then replace sensor.

PROBLEM		Possible cause/remedy	
4.	SPEED READOUT INTERMITTENT OR STAYS AT ZERO.	a.)	Fault is probably a broken or intermittent connection to wheel sensor or perhaps a faulty sensor. Check all connections first.
		b.)	Make sure clearance between wheel magnet and wheel sensor is 15-20 mm. Check for the correct sensor, it should be black.
		c.)	Enter "TEST MENU" from the "DISPLAY" in the "CALIBRATION MENU". Disconnect wheel sensor from cable and use a short length of wire to short circuit across connector plug to wheel sensor cable (black & white wires). Controller in cab should 'beep' continuously whilst wires are short circuited. Now wriggle all connections from wheel sensor plug back to controller to try and make beep sound fail thereby isolating cause of fault.
		d.)	If wiring and controller can not be faulted, replace sensor.
		f.)	If no audible response in "TEST MENU" from shorting out wiring at wheel sensor connection, short out pins A and Q in the Deutsche breakaway. If still no response, remove 25 way connector from controller and short circuit directly across pins 1 and 22 of controller. If still no response return controller to nearest Farmscan dealer for repair.
5.	WHEEL SENSOR TEST PROCEDURE.	a.)	USE A MULTIMETER ONLY TO TEST THE WHEEL SENSOR. Disconnect wheel sensor from cable.
		b.)	Switch Multimeter "ON: and select "OHMS" scale.
		c.)	Touch test probes together and meter needle should read zero "0 Ω" resistance.
		d.)	Connect test probes to wheel sensor pins. If meter goes immediately to zero without magnet, then sensor is short circuit (faulty). If meter stays to left of scale, hold wheel magnet in front of sensor, meter should go straight to zero. If meter fails to change, then sensor is open circuit (faulty).

PROBLEM		Possible cause/remedy													
6.	TOTAL AND TRIP AREA INCORRECT.	a.)	Check "SPEED" readout is correct and steady - if not, this will affect the area totals. See Troubleshooting sections 3, 4 and 5.												
		b.)	Recheck "WIDTH" calibration is set correctly in <u>metres</u> .												
7.	TOTAL AND TRIP AREA WON'T RECORD.	a.)	Check that "SPEED" readout is working. If not follow troubleshooting point 3, 4 and 5.												
		b.)	At least one section valve must be switched on.												
		c.)	Flow sensor must be working OK.												
		d.)	Go to flush screen by pressing and holding "RESET" key for 3 seconds. Check that "L/MIN" or "G/MIN" is working.												
8.	RATE READOUT STAYS AT ZERO	a)	Check "SPEED" readout. If no speed follow Troubleshooting Section 3, 4 and 5.												
		b)	Use a multimeter to check for + 12 volts between red and black wires (on loom) to flow sensor. Check for +12 volts between pins 1 and 15 at rear of spray controller. <table border="0"> <tr> <td>Flow sensor wiring</td> <td>Loom wiring</td> <td></td> </tr> <tr> <td>Brown</td> <td>Red</td> <td>+12 V</td> </tr> <tr> <td>White</td> <td>Black</td> <td>Ground</td> </tr> <tr> <td>Green</td> <td>Grey</td> <td>Signal</td> </tr> </table>	Flow sensor wiring	Loom wiring		Brown	Red	+12 V	White	Black	Ground	Green	Grey	Signal
		Flow sensor wiring	Loom wiring												
		Brown	Red	+12 V											
		White	Black	Ground											
		Green	Grey	Signal											
		c)	Enter "TEST MENU" through the "DISPLAY" item in the "CALIBRATION MENU". "Use "NAV" to "FLOW".												
		d)	Disconnect flow sensor plug and use a short length of wire or long nose pliers to short out between the pins corresponding to the white and green wires of the flow sensor connector plug feeding back into the loom. Loom wires are grey and black.												
e)	A continuous beep should be heard from the spray controller. Now wriggle all wiring and connections from flow sensor plug to rear of spray controller and listen if the beep can be made to drop out.														
f)	If no beep heard, then repeat test by shorting out the Duetsche breakaway connected to 24V1 across pins A & J to determine if cable is faulty.														
g)	Remove 25 way connector and test directly across pins 1 & 9 of 24V1.														
h)	If no audible response directly into controller then return controller to your nearest dealer for service.														

PROBLEM		Possible cause/remedy	
9.	RATE LOW ALARM OR CAN'T REACH MAXIMUM SPEED.	a.)	Indicates target rate selected is not achievable.
		b.)	Check manufacturer's spray chart to see what rates should be achievable at maximum pressure.
		c.)	Check inline filters and nozzle filters which may be blocked causing restriction to achievable flow rate.
		d.)	Check flow sensor inlet for debris causing restriction.
10.	FLOW SENSOR INACCURATE.	a.)	Make sure flow direction arrow points in direction flow.
		b.)	If diaphragm or piston pump, make sure pump is not hammering.
		c.)	Remove flow sensor and check inlet strainer on flow sensor is clear.
		d.)	Follow flow sensor calibration and make sure correct flow cal factor is set.
		e.)	Follow "FLOW SENSOR SERVICING PROCEDURE"
11.	CONTROL VALVE WON'T OPEN AUTOMATICALLY.	a)	1. Check "WIDTH" calibration factor is correctly entered and make sure boom control switches are activating sections in "SETUP MENU 1". 2. Check "FLOW" cal factor is set. 3. Check "WHEEL" cal factor is set. 4. Check rates are set.
		b)	Check 25-way connector at rear of spray controller is inserted properly and check implement breakaway connection making sure pins on male side are contacting properly.
		c)	Check ground speed readout is working correctly.
		d)	If no pressure, make sure pump is working correctly.
12.	VALVE KEEPS OPENING WHILE SPRAYING.	a.)	Check speed readout is working accurately. Refer to troubleshooting sections 3,4 and 5.
		b.)	Follow troubleshooting 8 d.) to isolate flow sensor as cause.
		c.)	Read nozzle manufacturer's spray chart and make sure the intended rate can be delivered at the speed required within the minimum recommended operating pressure.

PROBLEM		Possible cause/remedy	
13.	VALVE RESPONSE TOO SLOW TO START SPRAYING.	a.)	If switching spray "OFF" regularly you must use "MASTER" section control to instantly start / stop spray.
		b.)	You must switch 'OFF' master switch whilst still travelling at working speeds . If you shut 'OFF' too late the valve will have opened to bypass.
		c.)	If centrifugal pump, when shutdown, pump must be able to cycle some material back to tank, otherwise cavitation may cause loss of pressure.
		d.)	If ground wheel is large ie greater than 2 metres travel then additional magnets may be required to improve response at slow working speeds.
14.	RATE HI ALARM ACTIVATES FOR MORE THAN 2-3 SECONDS.	a.)	Check valve operation.
		b.)	Check that you are not operating within the slow hold parameters.
15.	PRESSURE TOO LOW UNDER AUTO CONTROL.	a)	Check all calibration factors are correctly entered.
		b)	With boom spraying make sure
		c)	Run sprayer and check hoses for split after proportional control valve.
		d)	Make certain nozzles are correct for the job.

FLOW SENSOR SERVICE PROCEDURE

To be Followed Daily After Work is Finished

1. Unscrew the red cap and lift the turbine assembly out of the green sensor body.
2. Use clean water to wash away any foreign particles from the turbine assembly.
3. Use compressed air or simply blow without direct mouth contact into the turbine assembly to ensure the propeller spins freely.
4. Insert the turbine assembly into the housing and tightly fasten the red cap.

To be Followed After Every 50 hours of Operation

1. Unscrew the red cap and lift the turbine assembly out of the green sensor body.
2. Unscrew and lift out the yellow sensor from the turbine assembly.
3. Place the turbine assembly unit in a detergent bath for a few hours.
4. Remove the turbine assembly from the detergent bath and use compressed air to check that the propeller spins freely.
5. Reassemble the flow sensor making sure the yellow sensor and turbine assembly are tightly fastened.