

## **3.0 OPERATION**

### **3.1 POWER ON / OFF KEY**

Press the ON / OFF key to start Spray Monitor.

The display will start up confirming the Monitor type and Version number.

eg

The Version number relates to the current software installed in your monitor.

The display always reverts to SPEED after start up.

eg

**NOTE:** If CHECK CAL is displayed, then you must check all Calibrations Settings. See Calibration Procedure page 14.

If alarms are active, press RUN / HOLD key to silence beeper.

### **3.2 SPEED KEY**

Press the SPEED key once to display ground speed

eg

Press the SPEED key again to display current work rate expressed as HECTARES PER HOUR.

eg

If Pressure Sensor option used, then a special Split Screen function is available by pressing SPEED key again.

eg

### **3.3 TOTALS KEY**

The TOTALS key toggles between three functions.

#### **TOTAL AREA**

Press TOTAL key once to display TOTAL AREA worked.

eg

The TOTAL AREA can be RESET at the start of a Spraying program and left to accumulate daily to keep track of overall areas worked.

To reset TOTAL AREA press RESET key once to start reset process.

eg

Press RESET again to complete reset process or to abort reset process, press any other key to escape.

After reset of TOTAL AREA you will have the option to reset all TRIP memories 1 - 10 at the same time

eg

Press RESET again to reset all trips or to abort reset process, press any other key to escape.

#### **TOTAL DISTANCE**

Press TOTAL key again to display TOTAL DISTANCE.

eg

To reset DISTANCE press RESET key once to start reset process.

eg

Press RESET again to complete reset process or to abort reset process, press any other key to escape.

The TOTAL AREA and TOTAL DISTANCE will stop accumulating whenever the monitor is ON HOLD. See page 25.

## TANK LITRES

Press TOTAL again to display TOTAL LITRES USED.

eg TANK 1825L USED

To RESET TANK press RESET KEY to clear TOTAL after tank refilled.

## TANK ALARM

NOTE: Based on Tank Volume Calibration an alarm will activate when 100 Litres left.

eg TANK 100L LEFT

ie: If TANK VOL Calibration set for 2000 Litres then TANK ALARM activates after 1950 Litres sprayed.

If TANK USED display is not reset after Tank Volume fully used then a reminder alarm will activate.

eg RESET TANK ?

Press RESET to instantly reset TANK TOTAL

## 2.5 SETTING VARIABLE CALIBRATION FACTORS

Press CAL key to display SET UP unit default.

eg SET UP UNIT? NO

Press CAL again to proceed straight to Variable Factors.

eg TARGET RATE 0 LHA

Press UP / DOWN keys to set TARGET RATE

eg TARGET RATE 600 LHA

Press CAL again to set acceptable ERROR TOLERANCE +/- before Rate Alarm will activate.

eg TOLERANCE 5% NOTE: 0% = No Alarm

Press CAL again to set Pressure Hi Alarm Point (if used).

eg PR HI 400KPA NOTE: 0 KPA = No Alarm

Press CAL again to set Pressure Lo Alarm Point.

eg PR LO 150 KPA NOTE: 0 KPA = No Alarm

NOTE: Pressure Alarm points will not be displayed if Fixed Calibration pressure option is OFF.

Press CAL again to exit CAL routine or press any other key anytime to exit CAL routine.

Press CAL key to proceed to Wheel Calibration.

eg WHEEL 0.00 M

Use UP / DOWN to set Wheel Factor.

eg WHEEL 2.42 M

Press CAL to proceed and set Flow Sensor Calibration Factor.

eg FLOW CAL 27.4 PPL

Press CAL to proceed to TANK VOLUME Calibration and use UP / DOWN to set Total Litres in TANK.

eg TANK VOL 3000L

Press CAL to proceed to Pressure Sensor Calibration and leave OFF if no Pressure Sensor installed.

eg PRESSURE OFF

Use UP / DOWN key to select Pressure Sensor type, either 500 KPA or 25 BAR maximum. (if used)

eg PRESSURE 500 KPA

Press CAL again to end FIXED CALIBRATION SET UP and skip direct to Target Rate Calibration Factor.

### 3.4 TRIP AREA KEY

The TRIP AREA key allows the display of the sub total area for each of 10 separate plots or sections of land worked.

To display the current Trip Memory press TRIP AREA key.

eg TRIP 1 56.2 HA

TRIP 1 may be RESET to zero at any time or kept as a record by changing to TRIP 2, as explained below.

To reset Trip Memory press RESET key to START reset process.

eg RESET TRIP 1 ?

Press RESET key again to complete reset process.

eg TRIP 1 0.00 HA

To change current Trip Memory press UP or DOWN key to change current trip number on display.

eg TRIP 2 0.00 HA

**NOTE :** Previous Trip records can be viewed or reactivated by using the UP and DOWN keys to change the current trip memory on display. Whichever trip number is displayed will be active when working.

The RUN / HOLD key or Master Section Control can be used to stop the Trip area meter by placing the Monitor on 'HOLD' when travelling but not spraying.

eg MONITOR ON HOLD

### 3.5 RATE KEY & WARNINGS

The RATE key toggles between Application RATE, FLOW Rate and PRESSURE (if used), or split screen readouts of Rate together with SPEED, FLOW RATE or PRESSURE.

Press the RATE key to cycle through the choices. Application Rate is always on the right hand side of the screen.

eg 

RATE	100 LHA
4.8 KPH	100 LHA
52 LPM	100 LHA
280 KPA	100 LHA

Whichever choice is displayed will remain the first choice whenever the RATE key is pressed after having selected any other key.

#### RATE ALARM

Whenever the Application Rate varies either side of the Preset TARGET by more than the Preset TOLERANCE % then the alarm is activated and the display will automatically revert to your first choice RATE display, regardless of any other functions that may have been selected.

eg 

FASTER	68 LHA
--------	--------

This Alarm will repeat at 5 second intervals together with an operator prompt until such time as the Application Rate is restored to an acceptable Tolerance or the monitor is placed on HOLD.

#### OPERATOR PROMPTS

SLOWER if actual LHA is less than TARGET  
FASTER if actual LHA is greater than TARGET

The operator may adjust sprayer pressure or ground speed to compensate.

### 2.4 SETTING FIXED CALIBRATION FACTORS

Press CAL key to display SETUP option.

eg 

SET UP UNIT ?	NO
---------------	----

Use UP key to say YES

eg 

SET UP UNIT ?	YES
---------------	-----

Press CAL to proceed into set up mode.

eg 

SECTIONS	1
----------	---

Use UP / DOWN keys to select number of sections used.

NOTE: Choose 1 section if manually operated section valves. See Installation Page.10

Press CAL to proceed and use UP / DOWN keys to set WIDTH of Spray if one section.

eg 

WIDTH 1	12.00 M
---------	---------

if more than one section, switch all individual section switches OFF and Master switch 'ON'.

eg 

WIDTH	OFF
-------	-----

Now switch Section 1 'ON' and use UP / DOWN to set WIDTH of SECTION 1

eg 

WIDTH 1	4.50M
---------	-------

Now switch Section 1 'OFF' and switch Section 2 'ON', then set section 2 width.

eg 

WIDTH 2	2.50M
---------	-------

Now repeat process for switches 3 and 4 if used.

Switch all sections 'ON' to check overall width is correct.

eg 

WIDTH ALL	6.00 M
-----------	--------

Now flick Master Switch OFF and all Widths should be OFF.

eg 

WIDTH OFF	
-----------	--

### 2.3 CALIBRATION PROCEDURE

The Calibration Function is broken into two distinct areas.

1. FIXED CALIBRATIONS - Factors that you set once only.
2. VARIABLE CALIBRATIONS - Factors that you might change daily.

Fixed Calibrations must initially be set before Variable Factors can be entered.

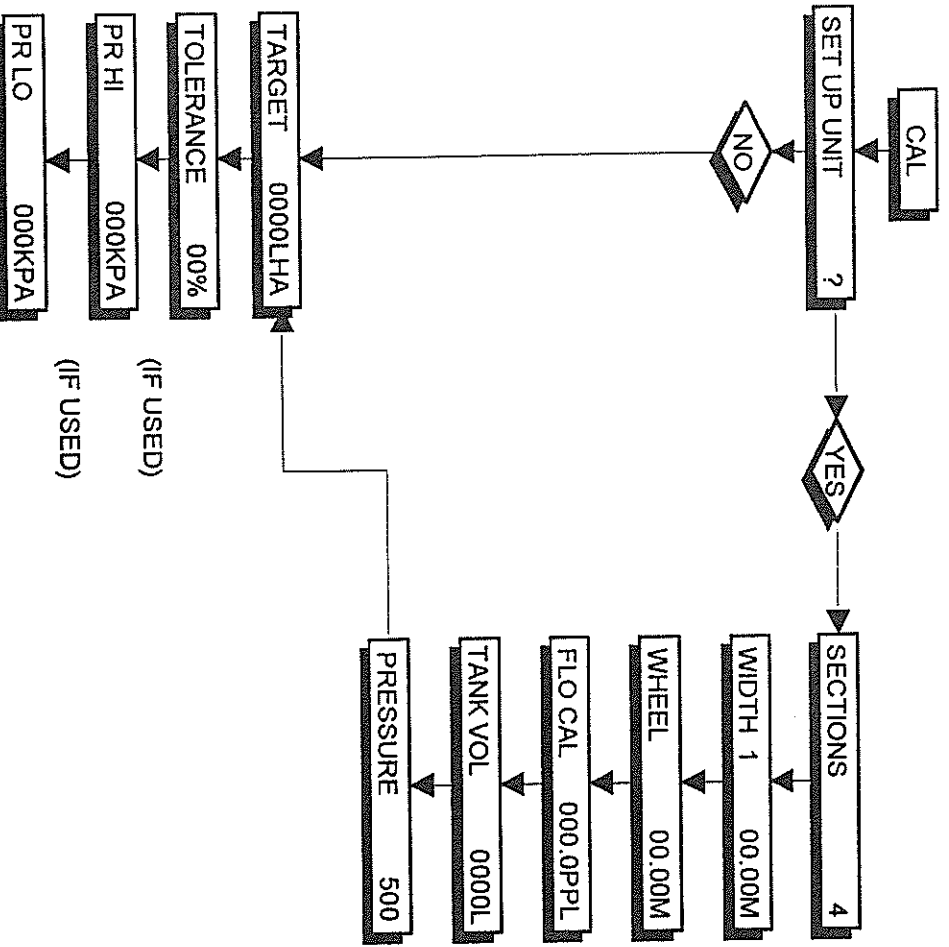

### PRESSURE ALARMS

If PRESSURE SENSOR option used, Pressure HI and / or LO alarm points may be set. See Calibration Procedure page 14.

Whenever Sprayer Pressure falls outside HI / LO limit points, the PRESSURE Alarm is activated on second priority to the RATE alarm.

The Pressure Alarm prompt is displayed alternately with the pressure display.

eg 

PR LO	100 LHA
120 KPA	100 LHA

The alarm will repeat at 5 seconds intervals until the pressure is restored to within the HI / LO limits or the monitor is placed on HOLD.

### 3.6 IMPERIAL / METRIC KEY

The Imperial / Metric key toggles all display functions from one measuring system to the other.

eg 

SPEED	10.0 MPH
SPEED	6.2 KPH

Imperial is UK Imperial.

NOTE: IMP / MET is not active in Calibration Setting. All Calibration Factors must be METRIC.

### 3.7 TIMER KEY

The TIMER Key allows display of the ELAPSED TIME of machine operation.

The ELAPSED timer can be RESET to zero at any point.

The RUN / HOLD key will STOP / START the elapsed timer.

If required the ELAPSED timer may be programmed with an elapsed time alarm point which can serve as a warning of a due maintenance interval etc.

Press the TIMER key to display the Elapsed Timer:

ELAPSED 00:00  
 ↑ ↑  
 HOURS MINUTES

To reset Elapsed Timer press TIMER key to select ELAPSED display, then press the RESET key.

#### TIMER ALARM

An elapsed time alarm may be set to activate after the elapsed display counts up to a set point.

To set Timer Alarm press TIMER key to display SET TIMER.

Use UP and DOWN key to set duration of time to elapse before alarm will activate.

SET TIMER 00:00  
 ↑ ↑  
 HOURS MINUTES

To start Timer press TIMER key to display ELAPSED TIME then press RESET to start timer counting up from zero.

To cancel Timer press TIMER key to display SET TIMER then press RESET to zero, timer alarm.

### 2.2 FLOWSENSOR FACTOR CALCULATION

Engraved on the underside of every FlowSensor is a factory checked Calibration Factor for water. eg PPL 28.4

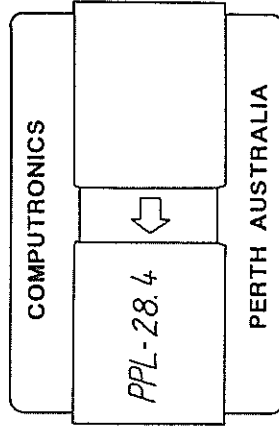

Calibration Factors may vary with Liquid Viscosity and different installations and should therefore be checked before spraying chemicals.

#### FLOWSENSOR TEST METHOD

#### **! WARNING - TAKE PRECAUTION TO AVOID SPLASHBACK INJURY**

For Best results, test should be carried out at normal operating flowrate.

1. Make sure FlowSensor is fully primed, remove a hose after manual or electric Control Valve to make START / STOP of Test more precise.

2. Prepare a container of known volume 20 Litres or more with accurate markings.

3. Switch monitor ON and press TEST key to display TEST FLOW, then press RESET to clear any total on display.

eg TEST FLOW 0

4. Start pump, open Control Valve until the required Test Quantity is obtained, then take note of the total pulses counted.

eg TEST FLOW 586

5. Check the liquid quantity with a graduated jug, then divide the total pulses by the measured quantity.

eg PULSES = 586  
LITRES = 21.4

586 ÷ 21.4 = 27.4 Pulses Per Litre

6. Repeat Test a couple of times to check accuracy then record factor for Flow Cal setting as explained in section 2.4.

## 2.1 WHEEL FACTOR CALCULATION

1. If the wheel sensor is subject to changing tyre load, then half fill tank.
  2. Measurement procedure must be performed in working conditions, not on a tarmac (recheck measurement when moving from hard to soft conditions).
  3. Switch monitor ON and press TEST key to display TEST WHEEL counter.  
eg 

TEST WHEEL	0
------------	---
  4. Creep vehicle forward and stop exactly on a pulse count, then press RESET key to bring TEST WHEEL counter back to zero.
  5. Peg ground at bottom centre of any wheel as a starting reference point for measurement.
  6. Drive forward for approximately 25 metres or more and stop exactly on a pulse count.  
eg 

TEST WHEEL	14
------------	----
- NOTE: Go forward, Do Not Reverse if you miss a pulse.
7. Now measure the exact distance travelled and divide the pulses counted into the distance covered.  
e.g. Distance 25.86 metres ÷ 14 pulses = 1.847 M / PULSE
  8. Record Wheel Factor for Calibration Setting as explained in section 2.4.

## 3.8 CALIBRATION WARNING

The SPRAY MONITOR keeps check that all your calibration settings remain constant. In some instances a Calibration Factor could change without your knowledge, for example due to electrical interference.

When a corruption is detected, the monitor will beep continuously and the readout will display CHECK CAL warning.

eg 

CHECK WHEEL CAL
-----------------

Press the CAL key and check all calibration factors.

## 3.9 MEMORY BACKUP

The monitor has a special internal back-up memory chip that keeps stored totals and calibration factors in memory even when the monitor is totally removed from the 12 volt D.C power source.

The internal memory chip has an expected life of 3 - 5 years.

When the memory chip fails, the unit will still function normally whilst the power switch is left on. If the memory has failed and you turn the power off, the calibration factors and totals will be erased. The CHECK CAL message will be displayed each time the monitor is switched 'ON'.

Return to the unit to your local dealer for replacement of the memory chip.

## 3.10 RUN HOLD FUNCTION

Press the RUN / HOLD key at any time to stop the Area Meters, Distance Meters, Elapsed Timer, and all Alarms.

eg 

MONITOR ON HOLD
-----------------

A reminder will activate at 30 second intervals whilst the monitor is ON HOLD.

Press the RUN / HOLD key again to place the monitor OFF HOLD.

eg 

MONITOR OFF HOLD
------------------

Alternatively the RUN / HOLD function can be activated by switching the Master Section Control switch OFF (if used), which then overrides the keypad RUN / HOLD status.

### 3.11 TEST KEY FUNCTION

The TEST key provides both a visual and audible indication of sensor operation and section input operation.

The TEST function is used both to establish Calibration Factors (See section 2.1 & 2.2) and to check sensor functionality as explained in Troubleshooting section of manual.

Press the TEST key to display Test Wheel.

eg TEST WHEEL 0

The TEST WHEEL function should beep and count each time the wheel magnet sweeps past the Wheel sensor.

Press TEST key again to display Test Flo

eg TEST FLO 0

The TEST FLO function will beep and count when the flowsensor turbine spins.

Press TEST again to display SECTION INPUTS according to number of sections set up in Fixed Calibration

eg TST SECTIONS 1234

Section numbers 1, 2, 3 & 4 will switch ON or OFF when section switches are switched ON or OFF.

Press TEST again to display pressure sensor resistance reading.

eg PRESS 180 Ohms

0 KPA	=	0 OHMS
260 KPA	=	100 OHMS
500 KPA	=	180 OHMS
OPEN CIRCUIT	=	200 OHMS
SHORT CIRCUIT	=	0 OHMS

## CALIBRATION

Before operating the SPRAY MONITOR you must establish and enter various Calibration factors relevant to your sprayer.

Once entered in memory these Factors will remain constant unless changed by the operator.

Follow the Wheel and Flow calculation procedure to determine these factors before proceeding to Set Up Unit - See section 2.1 & 2.2

By pressing the CAL key you can step from one Calibration Factor to the next. Each time you press CAL, the next question will be displayed.

Use the UP / DOWN arrow key to change a Calibration Factor on display, or to answer a question yes or no, then press CAL again to step onto the next question.

The RESET key can be used to zero any Calibration Factor on display.

If you wish to step back to a previous CAL option, you must first go out of CAL.

eg. Press SPEED key then start again by pressing CAL.



### 1.7 SECTION INPUT WIRING

When a separate Electric Control Panel is provided to shutdown Spray Sections, wire links can be made between the Spray Monitor and up to 4 Section Control Switches.

This Connection is required to enable the width of spray swath governed by each switch to be programmed into the monitor separately.

In this way, the READOUT of Rate and Area Sprayed is corrected whenever sections are switched ON / OFF, then the operator must make manual adjustments to pressure or speed to compensate.

**NOTE:** SPRAYERS with Manual Control Valves or levers can not be connected in this manner.

#### CONNECTION DETAIL

Your independent Section Control Panel must be connected to the same Tractor Battery 12 Volt source as the SPRAY MONITOR.

### ! DO NOT JOIN POWER WIRES OF SECTION CONTROL PANEL TOGETHER WITH SPRAY MONITOR POWER CABLE.

1. Disassemble your Section Control panel and locate the terminal or connection that is 'LIVE' when each section is 'ON' and 'DEAD' when the section is 'OFF'.
2. Use a Test Light or multimeter for this test.
3. Connect 4 Section Input Loom to monitor and run cables to Sections Control Panel.
3. Solder or join each Section Input Wire from monitor together with a switched wire from each Controlling Switch in the following sequence.

Section 1	=	WHITE
Section 2	=	ORANGE
Section 3	=	PURPLE
Section 4	=	GREEN

Remove any wires not used from 4 way plug.

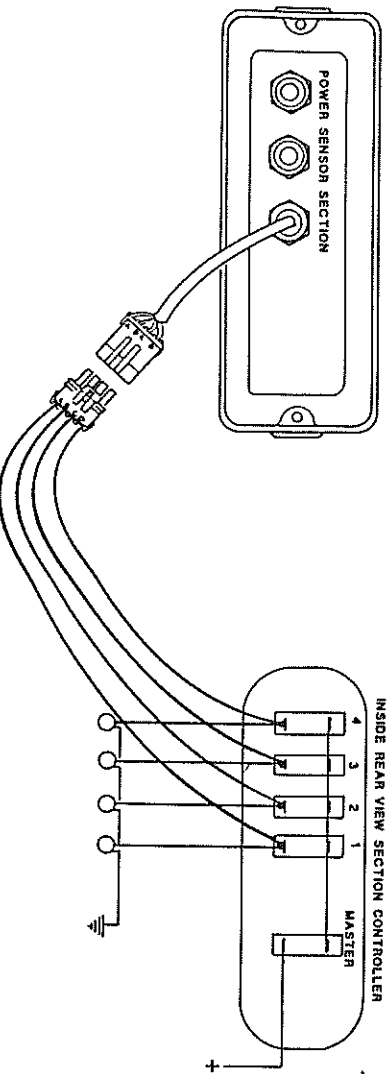

### 3.12 FLOWSENSOR OPERATION AND TESTING

When the Spray Monitor is switched on, the red light on the flow sensor indicates that power is reaching the Flowsensor.

The Green pulse light will flash when the turbine is turning. The rate of "flashing" will increase with higher flow rates, to the point where the green light will appear to be constantly "ON".

Before using the flow sensor with a tank of mixed chemicals, check the monitor is calibrated correctly, displaying the correct litre total.

See Flow Sensor Factor Calibration procedure in the Instruction Manual Section 2.2.

#### FLOW SENSOR MAINTENANCE

1. Flush the flow sensor with fresh water after use every day.
2. Do not leave waitable powders in the spraylines overnight or for long periods.
3. If flow sensor turbine is damaged or severely worn, install new AH-205 RED Turbine Replacement Kit.

**! CAUTION !**  
FLOW SENSOR MUST BE THOROUGHLY DECONTAMINATED BEFORE PERFORMING ANY MAINTENANCE OF WETTED PARTS.

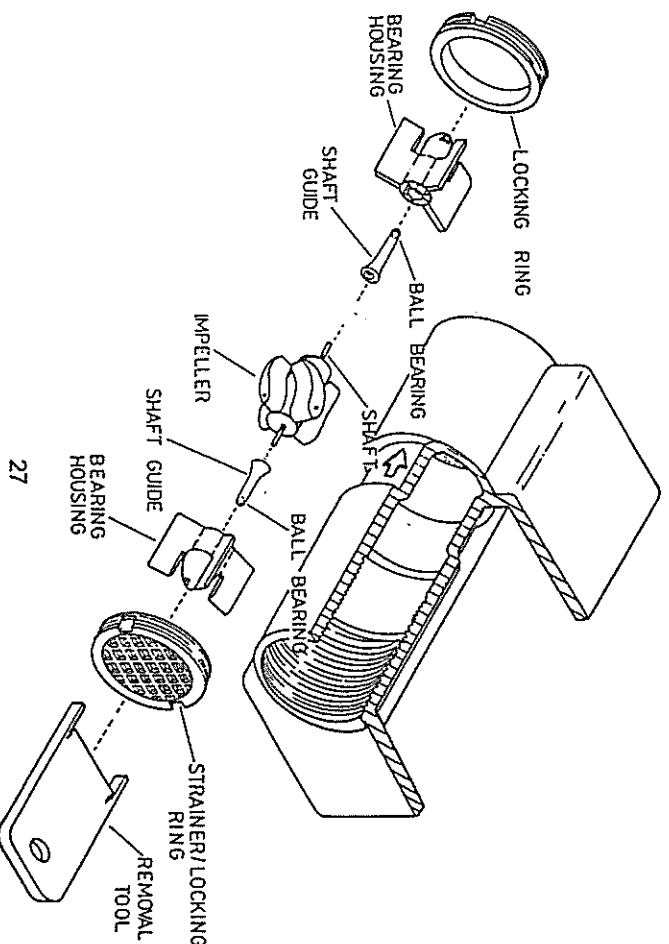

## 4.0 TROUBLESHOOTING 2300 SPRAY MONITOR

PROBLEM	POSSIBLE CAUSE / REMEDY
1. NO POWER TO MONITOR WHEN ON / OFF KEY PRESSED	<p>a) Remove fuse from inline Fuseholder and check using a multimeter or testlight - Replace with 1 AMP 3 AG fuse only.</p> <p>b) Test voltage at power cable is 12 - 13.8V dc from battery.</p> <p>c) Check that RED wire is to battery +ve and BLACK wire is to battery -ve.</p> <p>d) Check that no other electrical device is connected to the same power cable.</p> <p>e) Unable to locate fault - Contact nearest Dealer or Authorised Service Agent.</p>
2. LCD DISPLAY DROPS OUT OR GREY SQUARES APPEAR ON HALF THE READOUT.	<p>a) If display recifies when engine running this indicates battery in poor condition or dirty connections.</p> <p>b) If problem persists when engine running, then voltage supply is low or low current is problem due to poor connection at battery, corroded inline fuse holder in power cable, or other equipment connected to power cable.</p> <p>c) Clean battery terminals and power cable connections.</p> <p>d) Make sure power cable is <u>direct</u> to battery terminals.</p>
3. "CHECK CAL" ON DISPLAY - INDICATES CALIBRATION FACTORS LOST FROM MEMORY.	<p>a) See Calibration warning instructions Section 3.8 in this manual.</p> <p>b) If problem occurs regularly, then it is probably caused by outside interference. See "Interference Causes and Remedies" Section 5</p> <p>c) Alternatively, CHECK CAL will be caused by failure of memory backup chip. In this case all calibrations will be lost from memory whenever the power switch is turned "OFF". See section 3.8 this manual.</p>
4. LCD DISPLAY APPEARS SLOW TO CHANGE OR VERY BLACK	<p>a) Slow response is caused by cold conditions. This does not affect accuracy or warning systems. Display response will be faster at warmer temperatures.</p> <p>b) Black display is caused by high temperature &gt;60° Celcius. This will return to normal at lower temperatures.</p>
5. SPEED READOUT TOO FAST OR TOO SLOW	<p>a) Re check "WHEEL" Calibration is measured correctly and measured in Metres eg 2,445 metres.</p>

## 1.6 PRESSURE SENSOR INSTALLATION (OPTIONAL)

There are 2 types of Pressure Sensor available for use with the SPRAY MONITOR.

- 2015 PRESSURE SENSOR KIT (0-500 KPA)
- 2025 PRESSURE SENSOR KIT (0-25 BAR)

The Pressure Sensor is supplied complete with brass "Snubber" which acts to protect the Sensor Mechanism from chemical damage.

The top brass section of the Snubber may be unscrewed to allow cleaning of powder build up on the inlet side of the bottom section.

The sensor Mechanism should not be removed from the top brass section which contains a measured quantity of a special oil inside the Viton Sack.

### PRESSURE SENSOR INSTALLATION PROCEDURE.

1. Screw Pressure sensor unit into a 1/8" bsp threaded hole on the delivery line, immediately after the Flowsensor but before sectional valves. Use thread sealant (thread tape) to enable a liquid tight seal.
2. Connect the pressure sensor tail to the screw terminals on Pressure sensor, positioning the spring washer between the eye and the nut. Polarity of these wires is not important.
3. Plug the Pressure Sensor into Sprayer Loom socket with blanking plug.

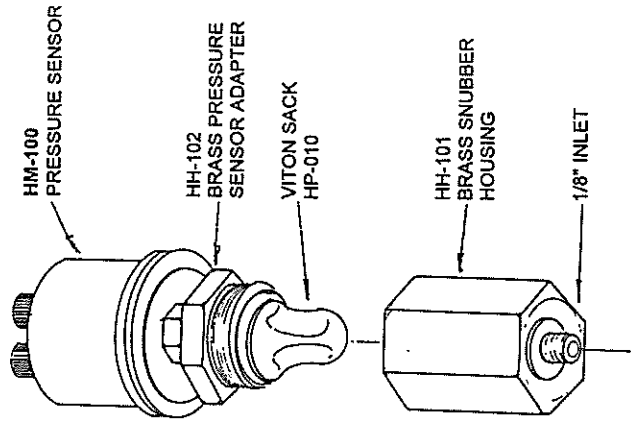

5. If the snubber inlet becomes blocked with suspension chemicals, place the bottom section of the snubber in a vice and gently unscrew top section containing oil in one piece. Clean bottom section and reassemble without disturbing viton diaphragm containing oil.

## 1.5 WHEEL SENSOR INSTALLATION

The standard WHEEL SENSOR supplied with the SPRAY MONITOR KIT, consists of a reed type sensor and two magnets to be fitted onto any UNDRIVEN ground wheel of the Tractor or sprayer.

Each magnet activates the Reed Type sensor as it sweeps past.

Alternatively Speedo Drive Cable, Radar or Tailshaft Sensors are available if required.

### WHEEL SENSOR INSTALLATION PROCEDURE

Bolt the Wheel MAGNETS onto the inside of wheel in a position that allows each magnet to sweep directly past the wheel sensor within 15 - 20 mm clearance.

MAGNETS must be exactly opposite to achieve the same interval between pulses.

The MAGNETS can be mounted anywhere in a radius from centre of the wheel. Nearer the hub will ensure the best ground clearance.

The SENSOR must be rigidly bolted to an existing structure, ideally in a protected position, to face the MAGNETS as shown.

If mounting the SENSOR on a steered wheel, make sure the SENSOR moves with the steering mechanism to maintain equal clearance between the MAGNETS and SENSOR when turning from lock to lock.

Connect SENSOR to sprayer wiring loom, and use cable ties to secure cable away from potential damage. Allow enough slack for axle movement and steering.

**NOTE:** Magnet thread may be cut off and magnet glued onto wheel using Araldite.

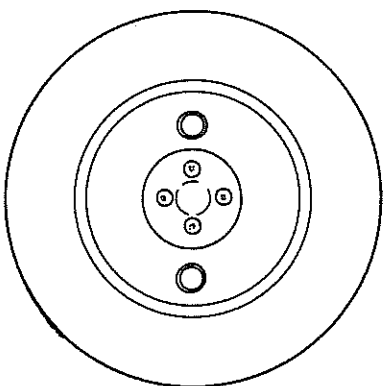
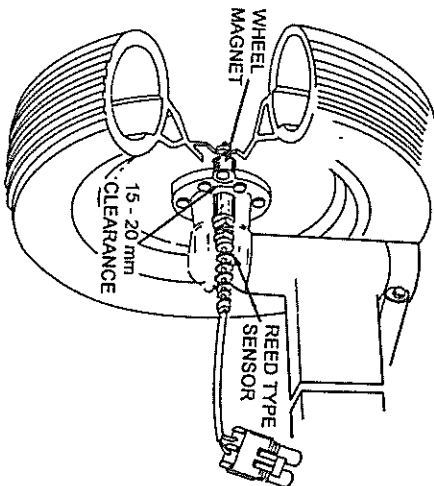

## TROUBLESHOOTING 2300 SPRAY MONITOR

PROBLEM	POSSIBLE CAUSE / REMEDY
6. SPEED READOUT JUMPY	<p>a) Make sure magnet is facing sensor correctly as shown in section 1.5 "WHEEL SENSOR INSTALLATION". (Use of an alternative magnet may cause problems due to wrong orientation.)</p> <p>b) If two magnets used, problems could be uneven spacing of magnets.</p> <p>c) Check that Wheel Magnet is 15 - 20 mm away from Wheel Sensor as they pass. Magnet too close can cause jumpy speed.</p> <p>d) If readout is jumpy, it indicates that the impulses from the sensor are inconsistent. Check for poor or intermittent connection to sensors.</p> <p>e) Is the wheel looser?</p> <p>f) If fault can not be found, press Test key on monitor until TEST WHEEL is displayed. Drive slowly forward and listen to the beeps. The sound should be consistent and steady at a fixed speed. If the sound is jumpy, wiring is OK, then replace sensor.</p> <p>g) If magnets and sensor <u>not</u> aligned and beeps can be heard whilst stationary, then interference could be the cause. See Troubleshooting Section 5 "Interference Causes and Remedies".</p>
7. SPEED READOUT STAYS AT ZERO	<p>a) Check Wheel Calibration is set correctly - not zero.</p> <p>b) Check clearance between wheel magnet and sensor is 15 - 20mm.</p> <p>c) Press TEST key to display TEST WHEEL then disconnect sensor at furthest point from monitor</p> <p>d) Use a short piece of wire or long nose pliers to make a short circuit across the pins corresponding to black and white wires of sensor cable connected to the monitor.</p> <p>e) If the monitor beeps with short circuit then Monitor and wiring ok- replace Sensor.</p> <p>f) If no response repeat short circuit test at draw bar connection back to monitor. If beep ok, then cable to sensor at fault.</p> <p>g) If still no response, Short circuit across pins C and F of 6 way connector plug into monitor. If beep ok, then cable to draw bar at fault.</p> <p>h) If no response, return monitor to your nearest Farmscan Dealer or Authorised Farmscan Service agent.</p>

## TROUBLESHOOTING 2300 SPRAY MONITOR

PROBLEM	POSSIBLE CAUSE / REMEDY
8. TOTAL AND TRIP AREA INCORRECT OR WONT RECORD	<p>a) Check SPEED readout is correct and steady - if not, this will affect the Area totals. See Troubleshooting Section 5, 6 or 7</p> <p>b) Recheck Width calibration is set correctly in <u>metres</u>.</p> <p>c) Is the machine overlapping or overcounting headlands.</p> <p>d) Press RUN / HOLD key to make certain monitor is "OFF HOLD"</p> <p>e) If master section RUN / HOLD used, then unplug section input plug and monitor should go "OFF HOLD"</p> <p>f) If monitor goes OFF HOLD, then fault with section wiring.</p>
9. NO RATE READOUT	<p>a) Check SPEED readout, if no speed follow Troubleshooting 5, 6, or 7.</p> <p>b) Check correct Calibration of widths and number of sections.</p> <p>c) Check Flo PPL setting correct.</p> <p>d) Press TEST key and check TEST FLO response should beep and count rhythmically when Turbine turning.</p> <p>e) Check Flowsensor Red and Green light status and if OK proceed to (f) otherwise see trouble shooting 11 &amp; 12.</p> <p>f) Disconnect Flowsensor from main loom and press TEST key on monitor to display TEST FLO.</p> <p>Use a pair of long nosed pliers to intermittently short out across pins A (white) and B (black) of flowsensor loom connector plug back to monitor. DO NOT TOUCH PIN C RED!</p> <p>+ 12 Volts Monitor Flo TEST should Beep and count.</p> <p>If beep OK follow Troubleshooting 11</p> <p>If no response repeat TEST across pins B &amp; D of 6 way sensor connector plug into monitor.</p> <p>If still no response direct into monitor then return monitor for service.</p>

### 1.4 FLOW SENSOR INSTALLATION

The flow sensor must be installed in the main delivery line to the spray nozzles before any section controls such as solenoid valves or manual shut off taps. Ensure the Flowsensor can be easily removed for Turbine Servicing.

The operating flow rate must be in the range of 8 - 200 L/MIN and the maximum pressure must not exceed 68 BAR (1000 PSI).

Other Flowsensors are available through your FARMSCAN Dealer. To handle different Flowrates and pressures.

Check minimum & maximum L/MIN as follows:

$$\frac{L/HA \times WIDTH \times SPEED}{600} = L/MIN$$

$$\text{e.g. } \frac{300 L/HA \times 4 M \times 4 KPH}{600} = 8 L/MIN$$

Before installing the flow sensor, blow softly into the INLET side and check that the turbine spins freely also take note of the factory calibration number (eg. PPL 28.6) engraved on the body.

There must be no return flow to tank after the flow sensor metering point, all the liquid being delivered to the target must pass through the flow sensor.

#### **IMPORTANT:**

Ensure Flow Direction arrow points in the same direction to Flow.  
Use 1" BSPT Nipples to Connect IN & OUT of Flowsensor - incorrect or over length threads may damage Flowsensor.

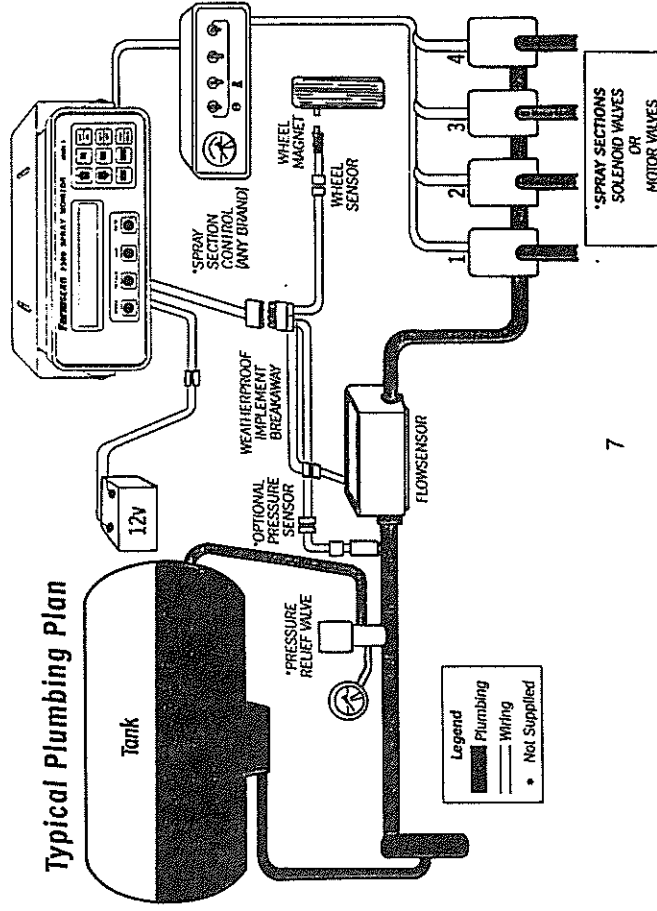

### 1.3 SENSOR & WIRING INSTALLATION

Install all sensors first, then lay out Sprayer Wiring Loom on machine and direct longest cable to the Wheel Sensor, and the shorter cables to the Flowsensor and Pressure Sensor.

Secure Sprayer Loom neatly to machinery framework with Cable Ties to avoid risk of damage.

An optional 5m Main Loom Extension Cable is available if required - Part No. AC-605. Individual 2 way or 3 way Sensor Extension Cables are also available if required.

The Sprayer Wiring Loom connects direct from the SENSOR INPUT Tail of the Spray Monitor to the Flowsensor, Wheel Sensor and Pressure Sensor (optional if used).

A separate tail Marked SECTION INPUT allows connection of up to 4 Independent Section Control Switches which must be linked to the Spray Monitor to enable adjustment of separate widths of operation and to Automatically place the "MONITOR ON HOLD" when the Master Section Control is switched "OFF".

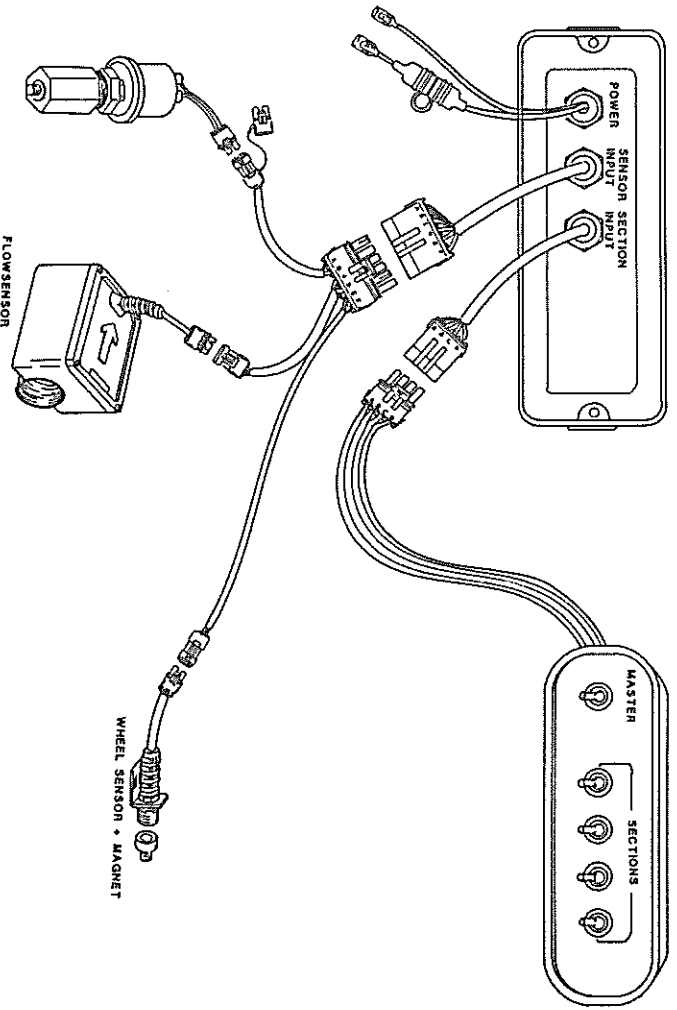

### TROUBLESHOOTING 2300 SPRAY MONITOR

PROBLEM	POSSIBLE CAUSE / REMEDY
10 WHEEL SENSOR TEST PROCEDURE	<p><b>DO NOT TEST WHEEL SENSOR WITH A TEST LIGHT, USE A MULTIMETER ONLY.</b></p> <p>a) Disconnect Wheel Sensor from cable.</p> <p>b) Switch Multimeter "ON" and select "OHMS" scale.</p> <p>c) Touch test probes together and meter needle should swing to right of scale indicating "∞" OHMS resistance. (If digital meter display - should read zero).</p> <p>d) Move Wheel sensor magnet away from sensor and connect test probes to Wheel sensor pins. If meter goes to zero, then sensor is short circuit (faulty). If the meter stays to the left of scale, move wheel magnet in front of sensor, meter should go straight to zero. If meter fails to change, then sensor is open circuit. (faulty)</p>
11 RED LIGHT ON FLOWSENSOR FAILS	<p>a) Check that monitor is switched ON.</p> <p>b) Check connection of plug into monitor.</p> <p>c) Check voltage into flowsensor is 12 - 14 volts between red and black wires at flow sensor connector plug of loom. If voltage OK, and sensor still fails, return sensor to your nearest Farnscan dealer or authorised service agent.</p>
12 GREEN LIGHT FAILS TO FLASH	<p>a) Check red light is ON.</p> <p>b) Disconnect flowsensor from sprayline and check Inlet strainer for blockage.</p> <p>c) Blow softly into Inlet (without mouth contact) and check that turbine spins freely.</p> <p>d) If turbine jammed or light does not flash then use removal tool to disassemble flowsensor.</p> <p>e) Inspect magnets (2x) embedded in turbine for build up of metal particles which may cause failure.</p> <p>f) Use toothbrush and soapy water to scrub magnets clean and reassemble turbine taking note of flow direction. Firmly tighten retaining ring and blow softly into inlet to check turbine spins freely.</p> <p>g) If unable to locate fault, return Flowsensor to your nearest Farnscan dealer, authorised service agent, or replace Turbine Part No. AH-205 Red Turbine Kit.</p>

## TROUBLESHOOTING 2300 SPRAY MONITOR

PROBLEM	POSSIBLE CAUSE / REMEDY
13. FLOW READING INACCURATE	<p>a) Follow Flow PPL Calibration Procedure in manual to make sure flow calibration factor is set correctly.</p> <p>b) If using a diaphragm or piston pump make sure pulsation dampener works properly - excess hammering may cause false readings.</p>
14. PRESSURE SENSOR WON'T READ OR READS FULL SCALE OR ZERO CONSTANTLY	<p>a) Check monitor Calibration set up to see the Pressure Sensor is set correctly ie "OFF" (if not used) or 500 KPA or 25 BAR</p> <p>b) Press TEST key to display TEST pressure readout.</p> <p>c) Short out terminals of pressure sensor and if readout drops to zero then Pressure Sensor is faulty.</p> <p>d) If readout stays high then fault in Cable or monitor itself.</p>

### 1.2 POWER CONNECTION

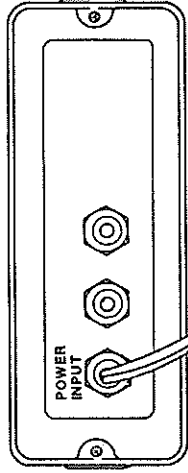

Connect independent power cable **DIRECT** to clean 12 Volt DC Battery Terminals.

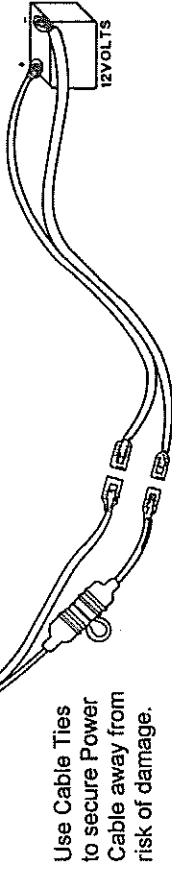

**! DO NOT CONNECT OTHER EQUIPMENT TO MONITOR POWER CABLE**  
**- INTERFERENCE MAY RESULT.**

#### TYPICAL BATTERY HOOK-UPS

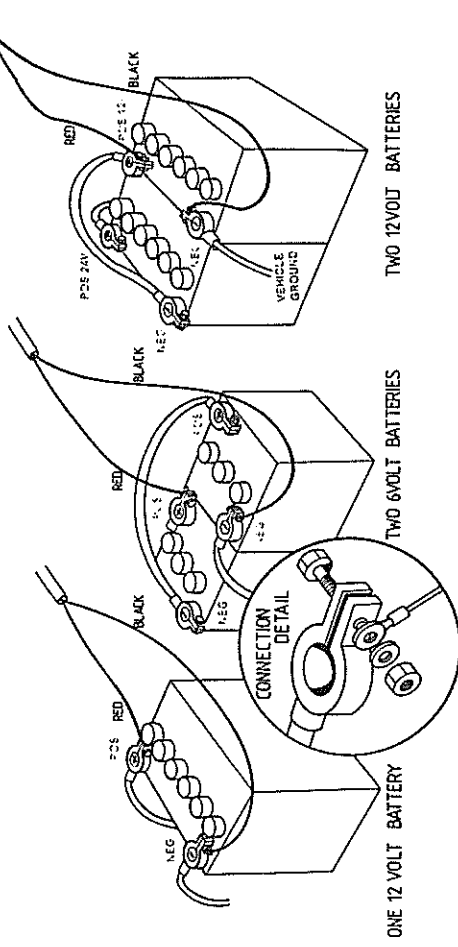

**! DISCONNECT MONITOR POWER CABLE WHEN ARC WELDING ON MACHINERY.**

## 1.0 INSTALLATION

### 1.1 MONITOR INSTALLATION

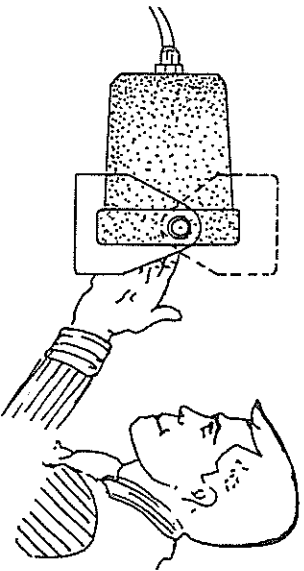

#### **CAB TRACTORS**

Install monitor on bracket supplied clearly visible to operator & within easy reach of section ON / OFF controls (if used).

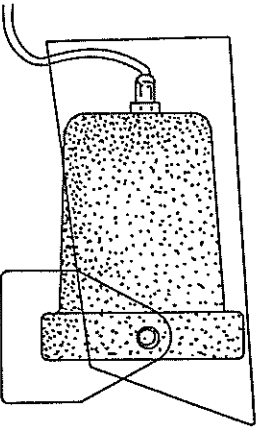

#### **OPEN TRACTORS**

Install monitor in horizontal position and use Weather cover & Bracket to protect monitor from direct weathering.

Monitor is sealed and able to withstand light overspray. Remove from sprayer when not in use.

**! DO NOT WASH DOWN MONITOR WITH HOSE OR PRESSURE CLEANER.**

## 5.0 INTERFERENCE CAUSES AND REMEDIES

CAUSES	REMEDIES
Noisy wire ignition leads on petrol engine or pump motor.	Replace with Carbon leads. Fit suppressors to coil and distributor.
Faulty Alternator	Exchange it
Other electrical equipment running off monitor power cable	Run separate power cable DIRECT to 12V battery for Monitor.
Calibrations get corrupted when solenoids / clutch switched off.	Make sure Monitor has its own separate Power Cable direct to 12V Battery. Fit diode across solenoid coil / clutch to clamp spike. Run power cable Physically away from solenoid / clutch wiring.
2 Way Radio interferes with monitor	Move monitor away from radio or shield monitor from radio with aluminium foil connected to chassis or install monitor in metal box.
Monitor upsets FM radio	Connect monitor to different battery - if problem goes away fit power cable suppressor.  Boost aerial signal to radio - shield monitor from radio using aluminium foil wrapped around monitor and connected to chassis.  Move monitor further away from radio.

NEED MORE HELP? a) Contact nearest Farmscan Dealer.

b) Contact Computronics International P/L  
31 Kensington Street, East Perth  
Western Australia  
Ph: (09) 221 2121 Fax: (09) 325 6686

**PARTS PICTORIAL - 2300 SPRAY MONITOR MK 2 KIT**

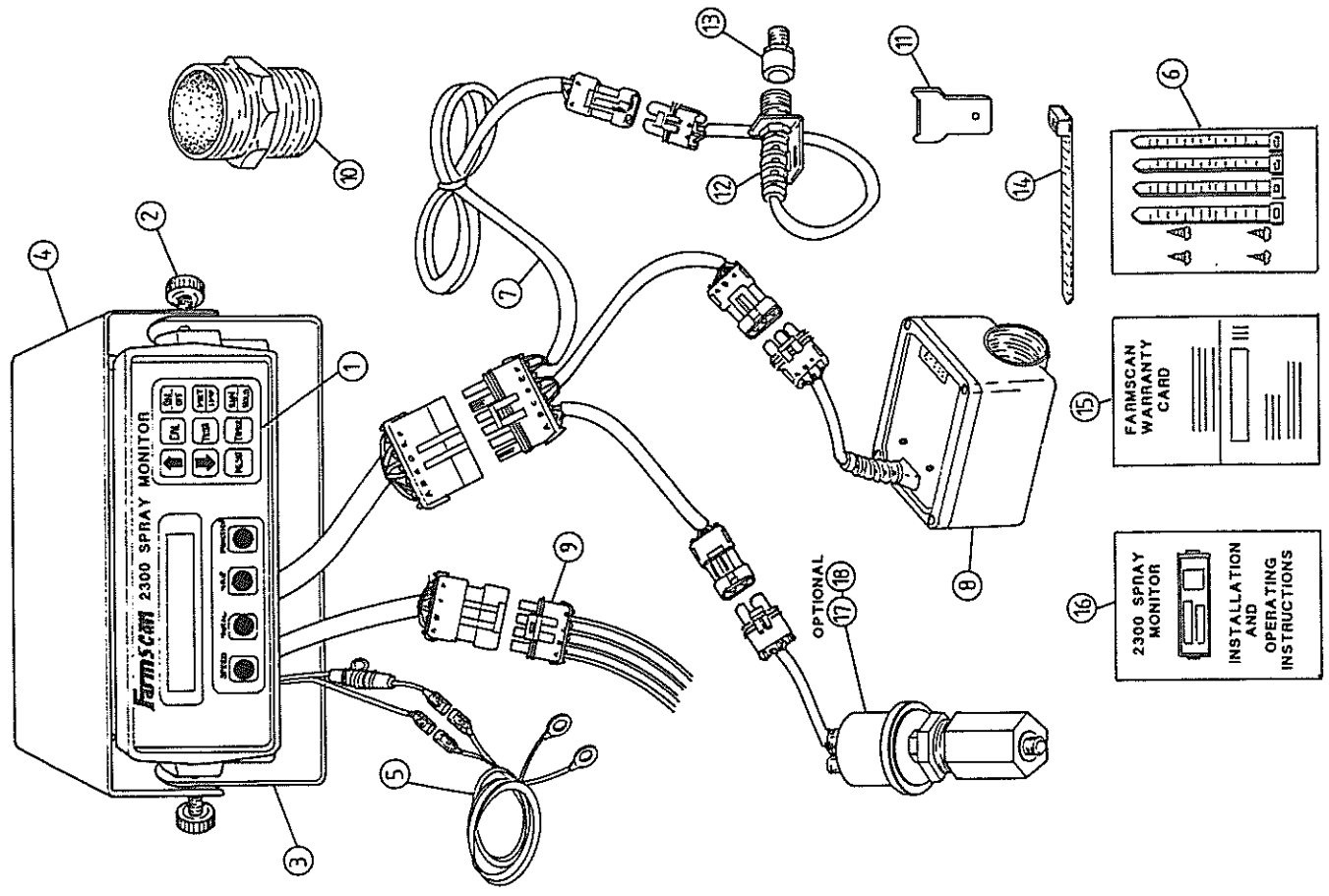



**PARTS LIST**

REF	PART NO.	DESCRIPTION	QTY
1	A-2300/2	SPRAY MONITOR MK 2	1
2	AH-861	SECURING KNOBS	2
3	AH-406	MONITOR MOUNTING BRACKET - XM	1
4	AH-501	WEATHER COVER XM SERIES	1
5	AC-101	8m POWER CABLE	1
6	AH-408	UNIVERSAL HARDWARE PACK	1
7	AC-2200S	SPRAYER WIRING LOOM	1
8	AA-200	TURBINE FLOWSENSOR (8-200 LPM)	1
9	AC-905	4 SECTION INPUT LOOM	1
10	HH-1100	1" POLY NIPPLE	2
11	AH-200	TURBINE TOOL	1
12	AA-110P	REED TYPE SENSOR	1
13	AA-133	MINI WHEEL MAGNET & NUT	2
14	HG-706	CABLE TIES	20
15	AM-200	WARRANTY CARD	1
16	AM-2300/2	INSTRUCTION MANUAL	1

**OPTIONAL SENSORS**

REF	PART NO.	DESCRIPTION
17	2015	PRESSURE SENSOR KIT (0-500 KPA)
18	2025	PRESSURE SENSOR KIT (0-25 BAR)

**OPTIONAL CABLES**

PART NO.	DESCRIPTION OF KIT
AC-205	5m 2 WAY EXTENSION CABLE
AC-305	5m 3 WAY EXTENSION CABLE
AC-605	5m 6 WAY EXTENSION CABLE

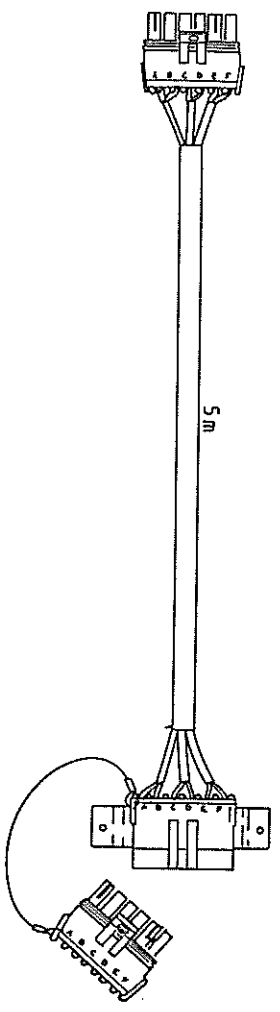

# CONTENTS

STANDARD AND OPTIONAL PART LIST	2
PARTS PICTORIAL	3
1.0 INSTALLATION	4
1.1 MONITOR INSTALLATION	4
1.2 POWER CONNECTION	5
1.3 SENSOR INSTALLATION AND WIRING	6
1.4 FLOWSENSOR INSTALLATION	7
1.5 WHEEL SENSOR INSTALLATION	8
1.6 PRESSURE SENSOR INSTALLATION	9
1.7 SECTION INPUT WIRING	10
2.0 CALIBRATION	11
2.1 WHEEL FACTOR CALCULATION	12
2.2 FLOWSENSOR FACTOR CALCULATION	13
2.3 CALIBRATION PROCEDURE	14
2.4 SETTING FIXED CALIBRATION FACTORS	15
2.5 SETTING VARIABLE CALIBRATION FACTORS	17
3.0 OPERATION	18
3.1 POWER ON / OFF KEY	18
3.2 SPEED KEY	18
3.3 TOTALS KEY	19
3.4 TRIP AREA KEY	21
3.5 RATE KEY & WARNINGS	22
3.6 IMPERIAL / METRIC	23
3.7 TIMER KEY	24
3.8 CALIBRATION WARNING	25
3.9 MEMORY BACKUP	25
3.10 RUN / HOLD FUNCTION	25
3.11 TEST FUNCTION	26
3.12 FLOWSENSOR OPERATION & TESTING	27
4.0 TROUBLESHOOTING	28
5.0 INTERFERENCE AND REMEDIES	33



# 2300 SPRAY MONITOR

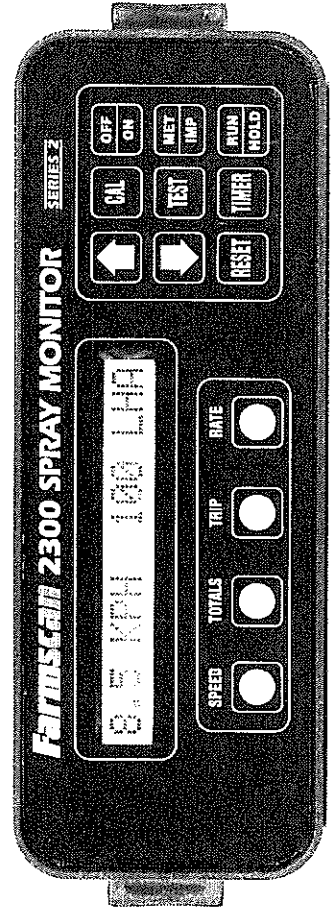

## INSTALLATION AND OPERATION INSTRUCTIONS

VERSION 2.0

PROPERTY OF  
**Computronics**



FARMSCAN - A PRODUCT OF COMPUTRONICS INTERNATIONAL PTY LTD.

PO BOX 8076,  
PERTH BUSINESS CENTRE,  
PERTH 6849  
WESTERN AUSTRALIA  
TELEPHONE: (09) 221 2121  
FACSIMILE: (09) 325 6686.

