

2009 TAILSHAFT SENSOR KIT

INSTALLATION INSTRUCTIONS

AM-2009

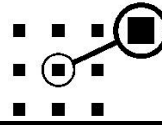

FARMSCAN

COMPONENT LIST

REF	PART No.	DESCRIPTION	QTY
1	AA-110P	REED TYPR SENSOR (PACKARD)	1
2	AA-423	TAILSHAFT MAGNET	1
3	AC-200	2 WAY 5 m CONNECTING CABLE	1
4	HG-702	CABLE TIES 150x3.5 mm	10
5	HS-8x1/2	SELF TAPPER 1/2x8G ZINC PLATED	4
6	AH-400	CABLE MOUNTING BRACKET	1
7	P-020	FEMALE TERMINAL 6.3 mm	1
8	P-022	MALE TERMINAL 6.3 mm	1
9	P-024	FEMALE INSULATOR	1
10	P-026	MALE INSULATOR	1
11	AM-2009	TAILSHAFT SENSOR INSTRUCTIONS	1

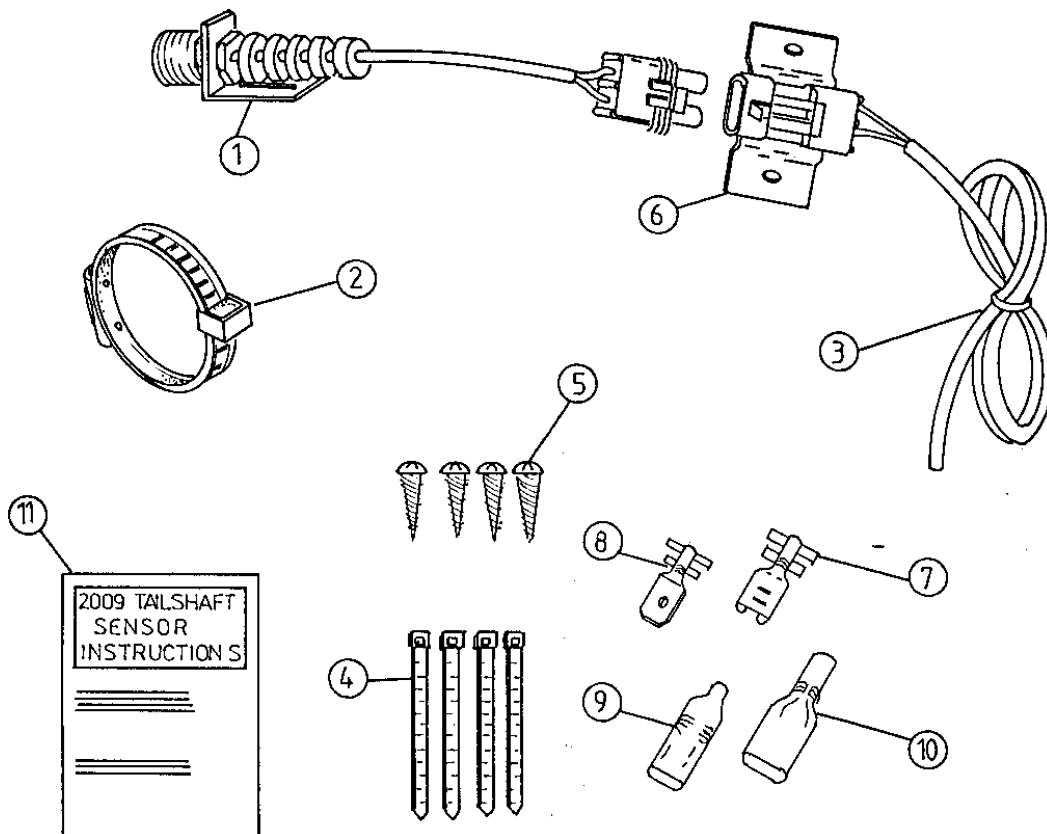

INSTALLATION

The Tailshaft Sensor Kit should be fitted at a point where vertical movement of the shaft is minimal, ie: the clearance between the magnet and sensor should remain fairly constant with a 10-15mm clearance. **Do not use substitute magnets.**

Best installation would be to install the sensor facing the side of the shaft, rather than directly above or below, except where the shaft is fixed, in which case the sensor may be positioned in any convenient location.

The sensor and magnet **must** face end to end.

Do not remove sensor from **aluminium** bracket supplied, damage will result.

The magnet may be transferred to another size hose clamp if necessary.

As the sensor is not affected by moisture or mud the main precaution is to protect the sensor and cable from physical damage. As a precaution, keep the sensor cable away from, aerial leads, engine kill switch cable or wires to electronic clutches and solenoid valves. Use cable ties supplied to secure sensor cable.

Make connection of tailshaft sensor into monitor, as explained in relevant monitor instructions.

