

tachometer **1200**

1200 TACHOMETER



INSTALLATION AND OPERATION INSTRUCTIONS

VERSION 1.0



PART No: AM – 1200

COMPONENT LIST - 1200 TACHOMETER KIT

REF	PART No.	DESCRIPTION	QTY
1	A-1200	TACHOMETER UNIT	1
2	AH-409	MOUNTING BRACKET (small)	1
3	AH-861	SECURING KNOBS	2
4	AC-205	5m 2 WAY SENSOR CABLE	1
5	AH-400	CABLE MOUNTING BRACKET	1
6	AA-112C	COMPACT COIL TYPE SENSOR	1
7	AA-117	SHAFT MAGNET WITH CLAMP	1
8	AA-105	PULLEY MAGNET	1
9	AC-101	8m POWER CABLE	1
10	AH-408	UNIVERSAL HARDWARE PACK	1
11	AM-1200	1200 TACHOMETER MANUAL (12V)	1
12	AM-200	WARRANTY REGISTRATION CARD	1

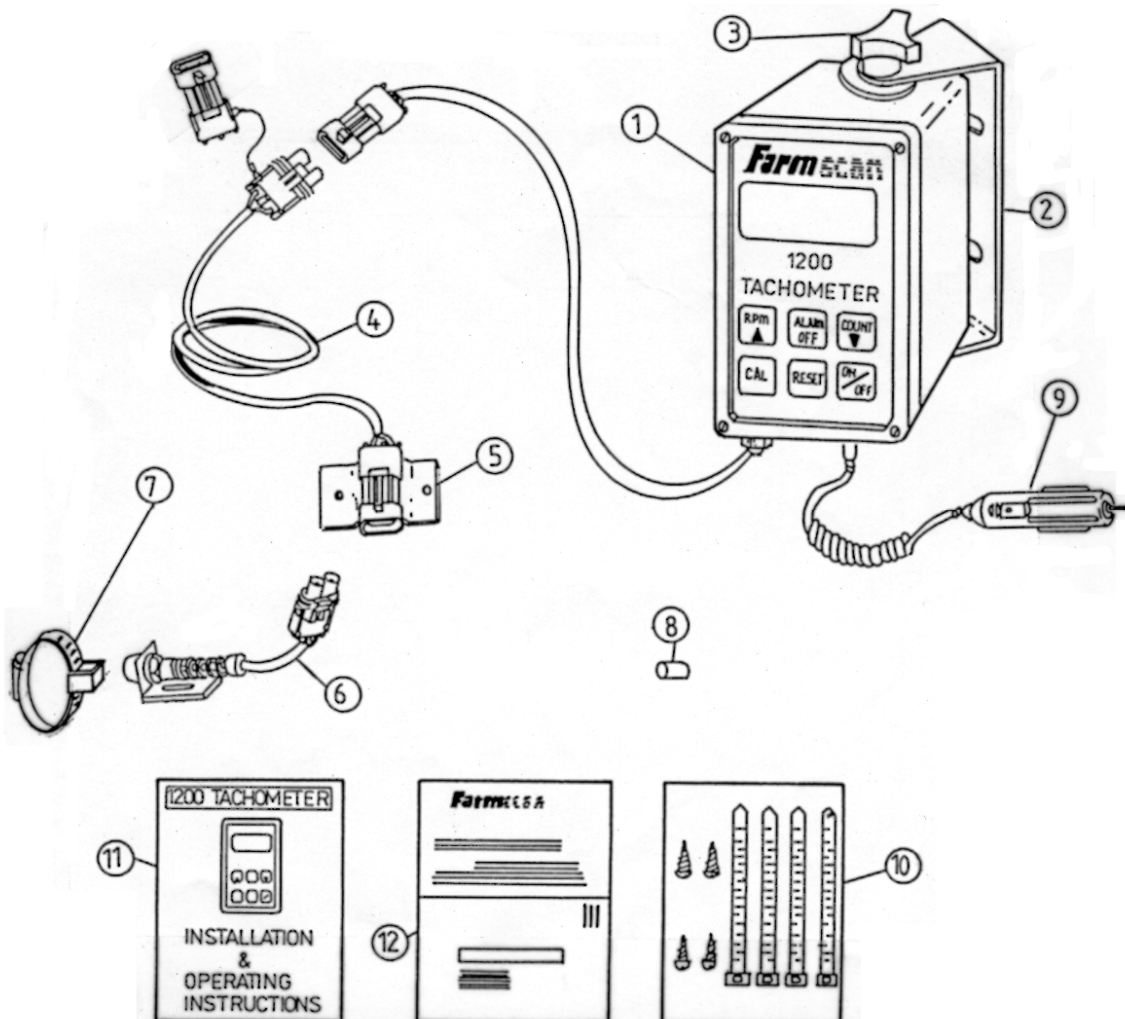

GENERAL INFORMATION

The *1200 Tachometer* is designed to fit virtually any farm tractor or implement to display shaft speed in (R.P.M.) or count events.

High and Low alarm points may be entered for audio indication that the shaft speed is out of the designated range.

Supplied in the kit is the COIL TYPE sensor which operates from 100 - 9999 RPM using either the shaft or pulley magnet supplied.

When used for shaft speeds under 100 RPM down to a 6 RPM minimum, or when used for counting purposes, a REED TYPE sensor must be used with either of the magnets supplied instead of the COIL SENSOR.

OPTIONAL: AA - 110P REED TYPE SENSOR

With shaft speeds under 6 RPM, 2 magnets may be mounted on the shaft directly opposite each other giving double the reading. ie. 8 RPM (display) = 4 RPM (shaft speed).

NOTE: If the magnets are not directly opposite, erratic readings will occur.

The 5 meter Sensor Cable supplied, may be extended to reach any implement shaft by using an optional 5 or 10 meter sensor cable, as an extension.

OPTIONAL: AC - 205 5m 2 WAY SENSOR CABLE
 AC - 210 10m 2 WAY SENSOR CABLE

If using the sensor cable as an extension to the rear of the tractor, use the cable mounting bracket (Ref 5 on parts table) to secure the connector away from hydraulic contamination and make sure dust caps are installed when cable is not being used. Dust caps should be plugged together when the cable is in use, to ensure they also stay clean.

NOTE: In very cold conditions, the display digits may appear to change slowly, but this will not affect the accuracy of the meter.

TACHOMETER INSTALLATION

The Tachometer Readout Unit is not waterproof and therefore must be installed in a tractor cab or must be protected against moisture. The warranty does not cover moisture damage. The unit is best mounted in a sheltered position out of direct sun light.

OPTIONAL : AH-500 WEATHER SHIELD KIT (1000 SERIES)

Use the bracket and securing knobs supplied to mount the unit in a convenient location.

POWER CONNECTION

Do not connect power until all other installation is complete.

The 8 metre POWER CABLE must be connected DIRECT to 12 volt DC vehicle battery terminals.

DO NOT join power cable with any other electrical equipment or the vehicle chassis, this may cause interference.

USE cable ties supplied to secure power cable away from risk of damage.

Connection to battery terminals must be clean and tight.

WARNING - Disconnect power cable from battery when arc welding on machinery as damage to the unit may result.

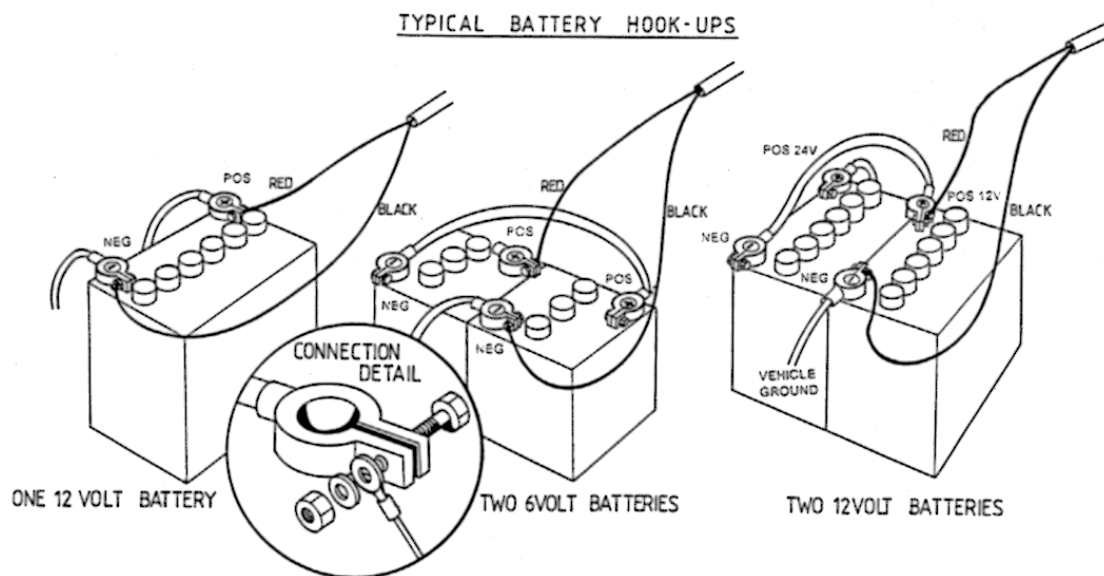

SHAFT MAGNET & SENSOR INSTALLATION

1. Clamp the shaft magnet around a shaft or lock collar. The clamp is adjustable from 19 - 38mm diameter. The magnet may be transferred to a larger clamp if necessary. Do not use substitute magnets.

NOTE: With shaft speeds less than 500 RPM, a shaft diameter of 30mm or more is recommended. Otherwise use an AA - 110P REED TYPE SENSOR.

2. Mount the sensor facing the magnet as shown below, with an adjustable clearance of 5 - 15mm.

Do not remove sensor from aluminium bracket supplied, damage will result.

3. Connect sensor to sensor cable and secure cable away from risk of damage using cable ties supplied.

As the sensor is not affected by moisture, the main precaution is to protect the sensor from physical damage. As a precaution the shaft sensor cable should be kept away from, aerial leads, engine kill switch cable, or wires to electronic clutches and solenoid valves.

SENSOR ADJUSTMENT PROCEDURE

Run shaft to approximate working speed, then carefully adjust sensor clearance until RPM readout is stable. Lock sensor in position.

NOTE: Readings may be erratic if sensor is mounted too close to magnet and readings will fade away if sensor is too far away.

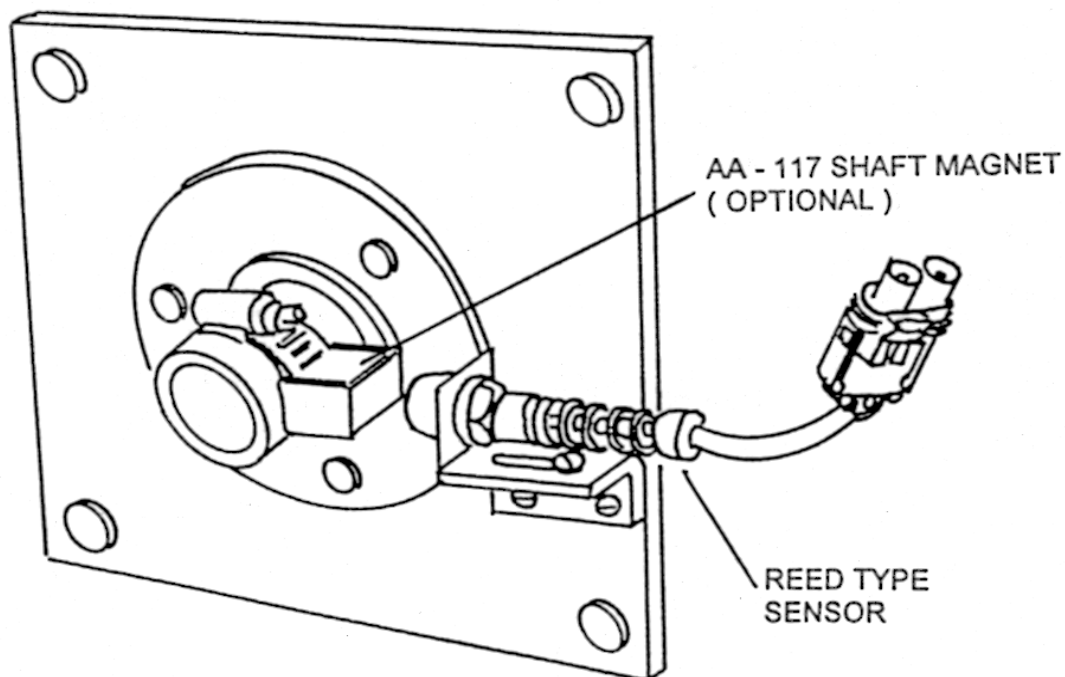

PULLEY MAGNET & SENSOR INSTALLATION

1. Locate a suitable position on the pulley that will accommodate the pulley magnet, embedded to approximately half it's 15mm length.

NOTE: If pulley speed less than 500 RPM, then magnet should be installed at least 50mm out from centre of pulley. Otherwise use an AA - 110P REED TYPE SENSOR.

2. Drill a 10mm clearance hole to a depth of 7mm into the pulley. Apply Araldite to one end of the magnet and gently tap the magnet into the hole. Do not embed the magnet fully into the pulley.
3. Mount the sensor facing the magnet as shown below with an adjustable clearance of 5 - 15mm.

Do not remove sensor from aluminium bracket supplied, damage will result.

4. Connect sensor to sensor cable and secure cable away from risk of damage using cable ties supplied.

As the sensor is not affected by moisture, the main precaution is to protect the sensor from physical damage. As a precaution, the shaft sensor cable should be kept away from, aerial leads, engine kill switch cable, or wires to electronic clutches and solenoid valves.

SENSOR ADJUSTMENT PROCEDURE

Run pulley to approximate working speed, then carefully adjust sensor clearance until RPM readout is stable. Lock sensor in position.

NOTE: Readings may be erratic if sensor is mounted too close to magnet or the magnet is fully embedded, and readings will fade away if sensor is too far away.

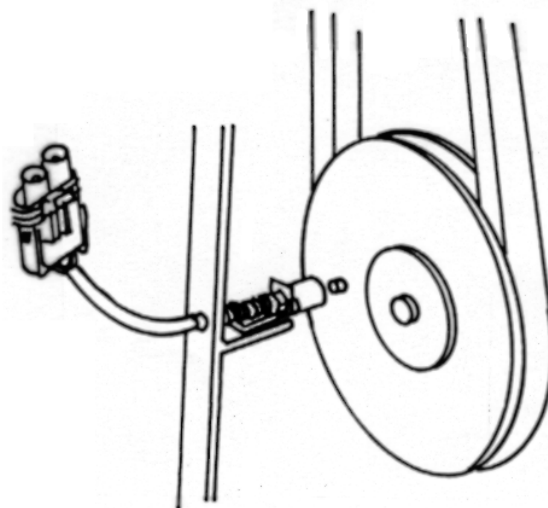

OPERATION

The RPM and COUNT function occur simultaneously. RPM may be displayed at any time without interrupting the COUNT function, and vice-versa.

ON/OFF KEY: The ON/OFF key toggles the Tachometer power ON and OFF. Whenever the unit is switched ON the RPM will be displayed first.

eg. RPM

From this point you can select any other key.

COUNT KEY: Press the COUNT key to display count total.

RESET KEY: After selecting COUNT, hold the RESET key down for approx. 3 seconds to clear the readout back to zero.

R.P.M. KEY: Press the RPM key to display shaft speed.

ALARM OFF KEY: Allows the alarm to be turned off whilst the RPM is above or below the set alarm points. Once the RPM has crossed back into the acceptable range, the alarm is automatically reset.

MEMORY: COUNT TOTALS are automatically stored in permanent memory every 6 minutes of operation or when the unit is switched OFF using the ON/OFF key.

The last 6 minutes of counting will be lost from memory if power is interrupted from source without first switching the unit off at the ON/OFF switch.

CALIBRATION

Alarm points can be set for HIGH and / or LOW RPM warnings on the shaft being monitored. Alternatively the unit can be set for NO ALARM AT ALL.

CALIBRATION WARNING

High and Low alarm points are permanently stored in memory whenever the CAL routine is completed as shown below.

If High or Low alarm calibration factors are corrupted due to outside interference the readout will display HELP to indicate the calibration factors must be re entered.

DETERMINING ALARM POINTS

1. Switch Tachometer ON (display RPM)
2. Run shaft up to operating speed, noting the shaft speed. It is from this speed that the High and Low alarm points may be chosen. The shaft speed will vary in normal operation depending on the load. The alarm points should be carefully chosen so as any small variation in shaft speed RPM will not continually activate the alarm.

SETTING ALARM POINTS

1. Switch Tachometer ON and press CAL key to display H1 (Low Alarm Point).

eg.

2. Use UP or DOWN arrow keys to set Low Alarm point.

eg. RPM

To eliminate the Low Alarm point, set H1 to 0000 using RESET key.

3. Press CAL key again to display H2 (High Alarm Point).

eg.

4. Use UP or DOWN arrow keys to set High Alarm point.

eg. RPM

To eliminate the High Alarm point, set H2 to 0000 using RESET key.

5. Press CAL key again to EXIT calibration routine.

TROUBLESHOOTING

PROBLEM		POSSIBLE CAUSE / REMEDY
1. NO RESPONSE FROM ON / OFF SWITCH	<ul style="list-style-type: none"> a) b) c) 	<p>Check that power cable connections at battery, are clean and tight.</p> <p>Measure voltage from power cable at monitor connection point, is it 12 - 13.8 V DC ?</p> <p>If voltage OK and unit fails, return to your nearest Farmscan dealer or authorised service agent.</p>
2. SHAFT SPEED ERRATIC	<ul style="list-style-type: none"> a) b) c) d) e) 	<p>If using a pulley magnet, it must NOT be fully embedded.</p> <p>Are the magnet and sensor facing end to end?</p> <p>Is the sensor too close to the magnet, follow the Sensor Adjustment Procedure. Page 4 or 5.</p> <p>Check wiring for loose / dirty connection, or physical damage.</p> <p>Follow TROUBLESHOOTING SECTION 4, to isolate interference as the cause.</p>
3. NO SHAFT SPEED / COUNT REGISTERING	<ul style="list-style-type: none"> a) b) c) d) e) 	<p>Is the sensor too far away from the magnet, follow Sensor Adjustment Procedure section of this manual.</p> <p>Is the magnet and sensor facing end to end?</p> <p>If shaft speed less than 100 RPM, fit REED TYPE sensor.</p> <p>Has a bearing collapsed, causing sensor to be out of adjustment.</p> <p>If still no response follow SENSOR & CABLE TEST PROCEDURE page 9.</p>
4. COUNT INCREMENTS ON IT'S OWN OR RPM DISPLAYED WHEN SHAFT STOPPED	<ul style="list-style-type: none"> a) b) c) d) 	<p>Switch off all other electronics to eliminate electrical interference as the cause. If switching off electronics eliminates the fault, ensure that the Tachometer cables are not running alongside wiring from other electronic devices, and / or physically move the position of the Tachometer in relation to the other equipment.</p> <p>If petrol engine in close proximity, stop engine to see if interference is caused by engine ignition system. NOTE: Carbon ignition leads must be fitted to spark plugs and coil to stop interference.</p> <p>Disconnect sensor from cable at shaft / pulley. If problem stops, replace sensor, or isolate cause of interference.</p> <p>Make sure Tachometer has independent power cable, wired direct to battery +/- terminals.</p>

TROUBLESHOOTING

PROBLEM		POSSIBLE CAUSE / REMEDY
4. COUNT INCREMENTS ON IT'S OWN OR RPM DISPLAYED WHEN SHAFT STOPPED continued...	e)	Disconnect sensor cable at the tachometer unit. If RPM displayed, return to your nearest Farmscan dealer or authorised service agent.
5. COUNT WON'T RESET	a) b)	a) After selecting COUNT, the RESET key must be held down for approx. 3 seconds. b) If COUNT still won't reset, return unit to your nearest Farmscan dealer or authorised service agent.
6. SENSOR AND CABLE TEST PROCEDURE	a) b) c) d) e)	a) Switch Tachometer ON, Press COUNT key and then RESET Count to zero. b) At the shaft / pulley sensor, disconnect the sensor from the sensor cable. c) Use a pair of long nose pliers and intermittently short the pins of the connecting plug on the cable together. The count readout should be incrementing each time the pins are shorted. If count increments, check that the sensor is setup properly. Follow the appropriate section on MAGNET & SENSOR INSTALLATION for the application used. If still no response from sensor, replace faulty sensor. d) If count does not increment, reconnect the sensor, and repeat the test at tractor breakaway plug (if used). If at this point the count increments, then the cable between the breakaway plug and the sensor itself is at fault. If still no response at tractor breakaway plug, repeat the test at connection directly into the Tachometer unit. e) If still no response directly into the Tachometer then return unit to your nearest Farmscan dealer or authorised service agent.

MULTIMETER TEST

COIL TYPE SENSOR

1. Disconnect sensor from cable.
2. Measure the resistance of the sensor, it should be 50 - 70 Ω

If the above is true, then the sensor is O.K..

If the above is not true, replace faulty sensor.

REED TYPE SENSOR

1. Disconnect sensor from cable.
2. Rotate the shaft / pulley so that the magnet is as close as possible to the sensor.
3. Measure the resistance of the sensor, it should be a short circuit.
4. Rotate the shaft / pulley so that the magnet is as far as possible away from the sensor.
5. Measure the resistance of the sensor, it should be an open circuit.

SENSOR CABLE

1. Disconnect Tachometer and Sensor from sensor cable.
2. Measure the resistance across the two terminals at the sensor end, it should be a open circuit.
3. Place a sturdy wire link across the two terminals at the Tachometer end of the cable and measure the resistance, it should be a short circuit.

If the above is true, then the sensor cable is O.K. (skip the following points).

If the above is not true then there is a fault in the cable.

4. Check that any breakaway connections in between are clean and firm to connect, if loose to connect, use a small object to close the female connection slightly.
5. Physically inspect cable for damage, it may have been crushed or cut.