

Air Seeder Monitor

1020 or 1020T

Installation & Operation Instructions



Farmscan Pty Ltd / ABN 76 632 674 545
Unit 4, 27 Mordaunt Circuit, Canning Vale WA 6155
www.farmscan.com.au / sales@farmscan.com.au

Sales: 08 6102 3200 / Support: 0480 018 282

Contents

- 1.0 Introduction..... 3
 - 1.1 General Outline..... 3

- 2.0 Installation 6
 - 2.1 Monitor Installation..... 6
 - 2.2 Power Connection 6
 - 2.3 Secondary Head Sensor Installation 7
 - 2.4 Sensor Cable Connection 11
 - 2.5 Sensor Cable Connection – 1020T Twin Shoot Model 12
 - 2.6 Initial System Checks 13

- 3.0 Operation..... 13
 - 3.1 Power 13
 - 3.2 Sensitivity Control..... 13
 - 3.3 Alarm..... 13

- 4.0 Parts List..... 14

- 5.0 Troubleshooting..... 17

- 6.0 Optional Bin Sensor Installation 20

1.0 Introduction

1.1 General Outline

Farmscan manufactures a 1020 Series Airseeder Monitor for both Single Shoot and Twin Shoot installations.

The Twin Shoot models (1020T) provided the ability to monitor two independent delivery systems simultaneously. For example, seed and fertiliser may be delivered to separate distributor heads and independently monitored for blockages.

The Farmscan 1020/1020T Airseeder Monitors detect secondary head blockages by means of sensors (listening devices) bolted onto each secondary distributor head.

Material flowing through each distributor head strikes the sensor mounting bolt which conducts the sound into the sensor.

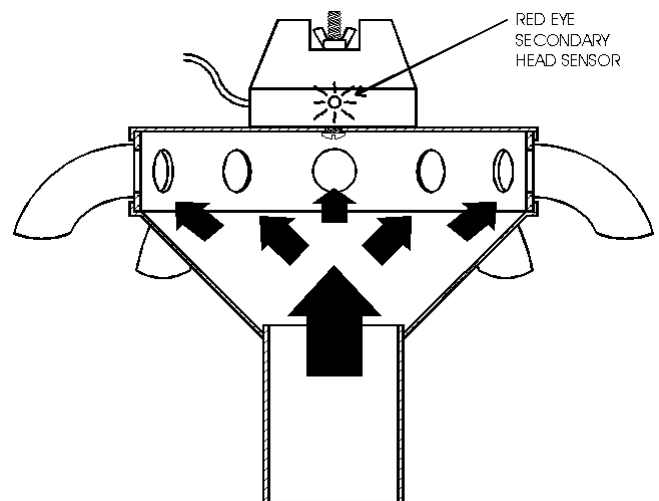

The operator is able to adjust the control unit sensitivity so that a bright red light on each sensor is held in the “OFF” condition for a given rate of seed and fertiliser.

When a blockage occurs, a red light will illuminate on the relevant sensor and simultaneously activate the cab alarm and warning light.

The operator will flick the “HOLD” switch, thereby freezing the red light on at the blockage point before stopping the machinery.

A simple inspection of all the sensors will indicate which head is blocked.

Up to 21 Secondary Head sensors may be installed on the same party line wiring system together with optional low bin sensors that connect into the same common wiring loom.

Typical Installation Plan – Single Shoot Model

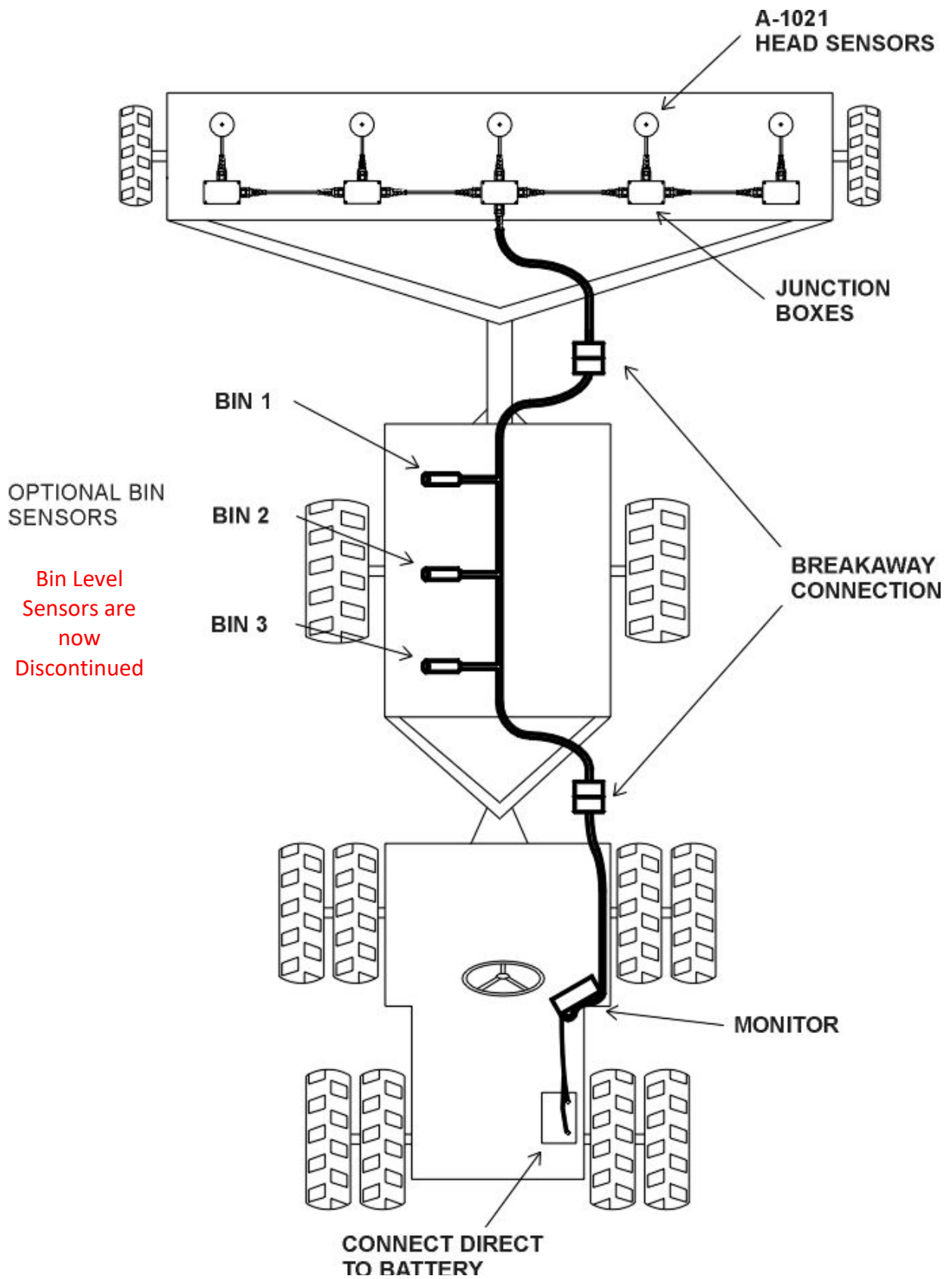

Typical Installation Plan – Twin Shoot Model

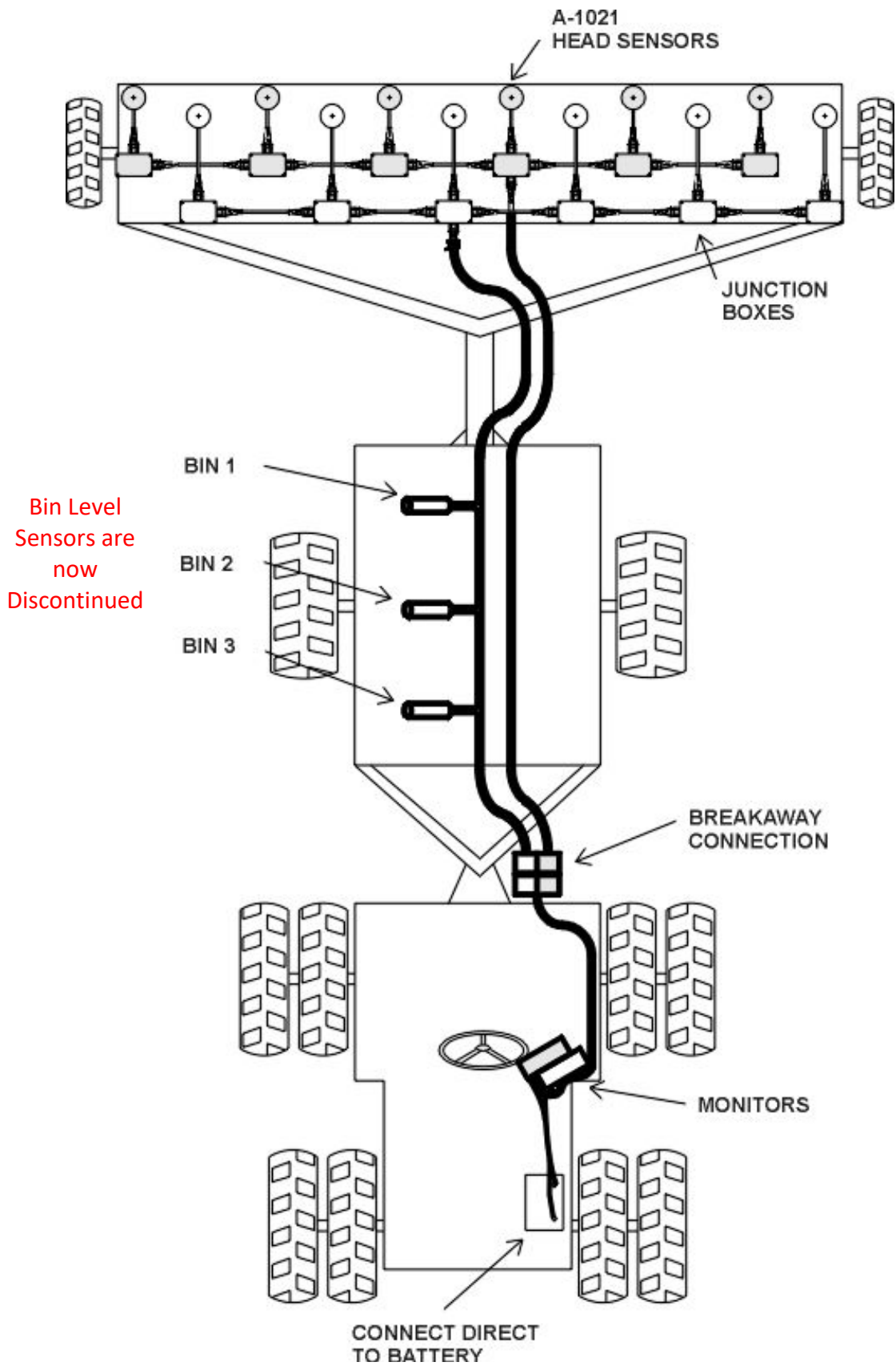

2.0 Installation

2.1 Monitor Installation

Install control unit in tractor cab using bracket and securing knobs supplied.

Alternatively, use bracket extensions to secure control unit above or below other Farmscan Monitors.

Refer to component illustrations pages 15-16.

2.2 Power Connection

Control unit must be connected DIRECTLY to the 12 Volt DC battery terminals, using the 8m supplied power cable. The unit has an internal poly fuse for protection, which if tripped will reset after a short period with the unit turned off.

There must be a minimum of 13.6v being produced from the alternator to battery while the tractor is running. Use a multimeter to confirm this.

Twin shoot model (1020T) is supplied with a power “Y” connector to supply power to each airseeder monitor.

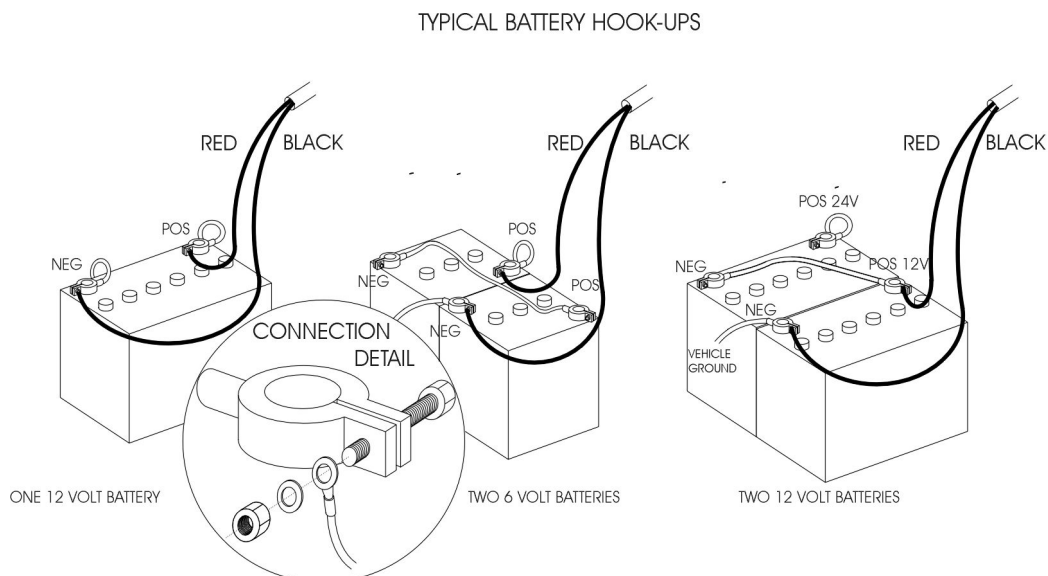

IMPORTANT:

- **DO NOT run this system from a JD power bar or cigarette lighter socket**
- A minimum voltage of 13.6v must be observed at all times.
- Make sure battery connections are clean and tight.
- Secure the power cable away from hot or moving parts with the supplied cable ties.
- Disconnect battery terminals when arc welding on machinery.

2.3 Secondary Head Sensor Installation

Sensors can be fitted in any way that provides a mechanical link between the sound of flowing material and the inner copper tube of each sensor.

The sensor must be isolated from the machinery framework to avoid false activation of the sensor through vibration. Ideally, the bolt will be isolated via the rubber wear pad inside the secondary head inspection cap.

HELPFUL TIPS

1. Face all sensor lights towards a single point to make checking easier.
2. Grease inside sensor tube will stop fertiliser build up and make removal of the bolt easier.
3. When not in use, drop a bag or old container over sensor head to stop parrots chewing the cable close to the sensor.

Find the installation option in the following pages that best suits your airseeder model.

Mount sensors upside down with copper spacer fitted as shown below to avoid distortion of rubber bounce cap for airseeder models shown below.

Example:

- John Deere
- John Shearer
- Big Rig
- Horwood Bagshaw
- Simplicity

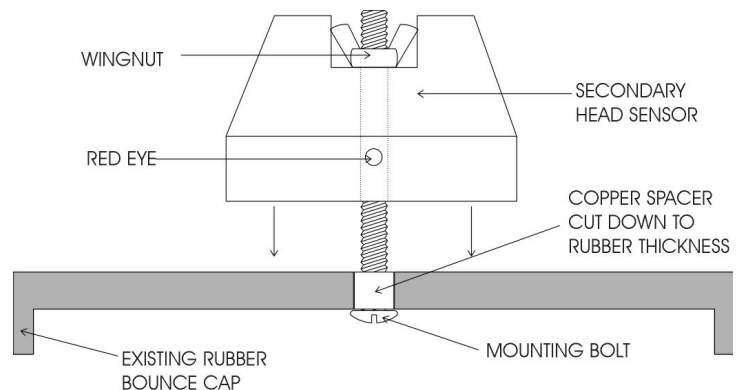

Existing nut must remain in place. Insert washers as shown below.

SUITS:

- Flexicoil

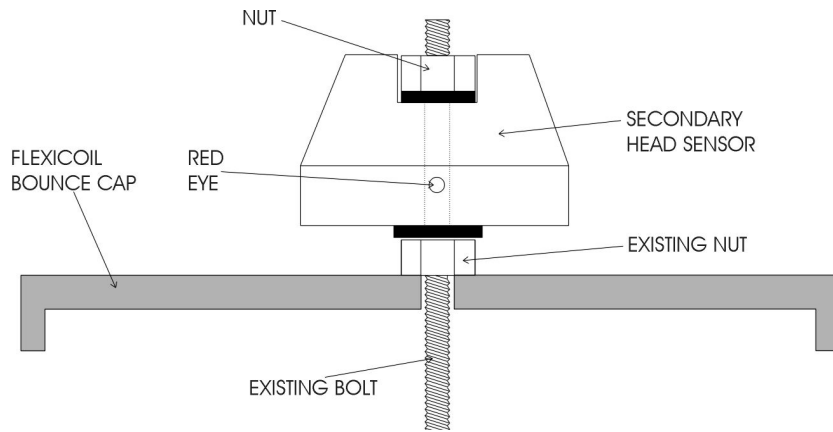

The sensor can be attached to the rubber feed hose as shown below - close to the distributor head.

Example:

- Early Ryan models
- Alfarm (CSN)
- New Holland
- Morris

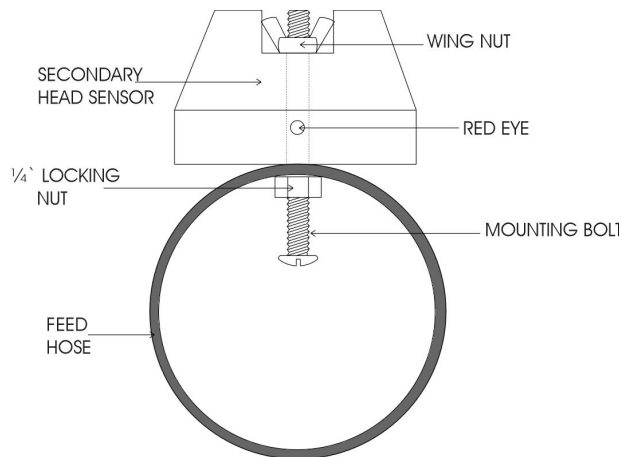

If mounting sensors with legs downwards, then copper spacer must be installed as shown below to prevent damage to sensor caused by over tightening wingnut.

Example:

- International
- Gason
- Ford
- Symonds

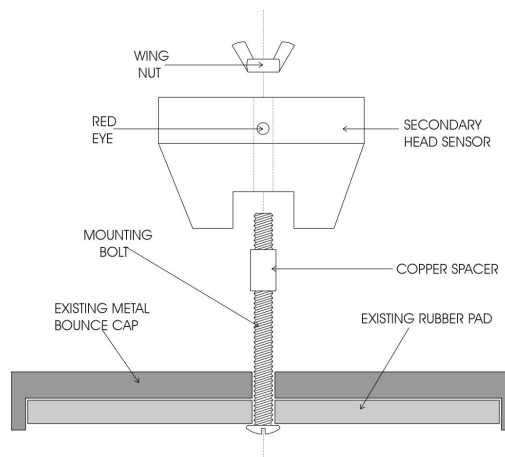

Mount the sensor centrally between drop tubes as shown below.

NOTE: With Connershea, airseeder springs may need to be modified to secure cap.

Example:

- Connershea
- Fusion

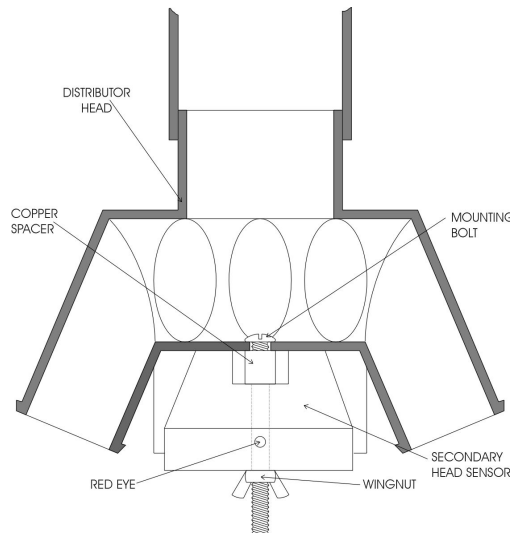

SUITS:

Napier
Simplicity (Metal Bounce Cap)

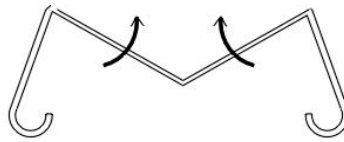

① EXISTING CAP SPRING

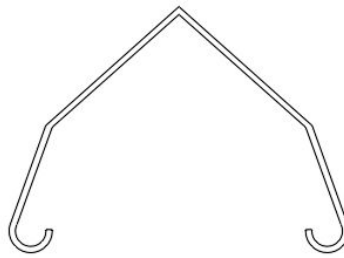

② INVERT TOP OF SPRING LIKE THIS

③

SECONDARY
HEAD SENSOR

GRIND
GROOVES
FOR SPRING
LOCATION

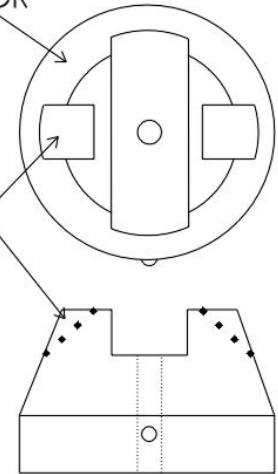

⑤

HEAD SENSOR
WITH GROOVES

SPRING

BOUNCE CAP

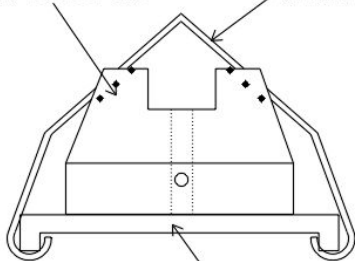

④

MODIFIED
SPRING

ALTERED
SENSOR HEAD

GRIND TOP FLAT SO
SENSOR SITS FLAT
ON CAP

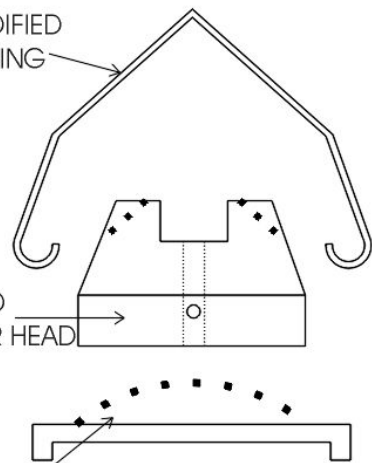

2.4 Sensor Cable Connection

Use the 5m tractor cable to connect from the monitor to the rear of the tractor.

Ensure breakaway socket is secured away from risk of contamination by hydraulic oil.

Use the separate 30 or 50 metre roll of 3 core sensor cable and 3 pin breakaway connectors to make up suitable extension cables to reach 4 way junction box mounted at centre of cultivator bar.

Interconnect all sensors using weatherproof junction boxes. Secure junction boxes and cables away from risk of damage using cable ties supplied.

Simply cut and join as required making sure to always match the same cable colours together in the Junction Box. A joiner block or insulated connectors are included in each kit.



Cable should be trimmed to a minimum of 70mm for easier install in junction box

Tighten weatherproof glands and seal junction boxes with silastic or grease around the lid before replacing screws.

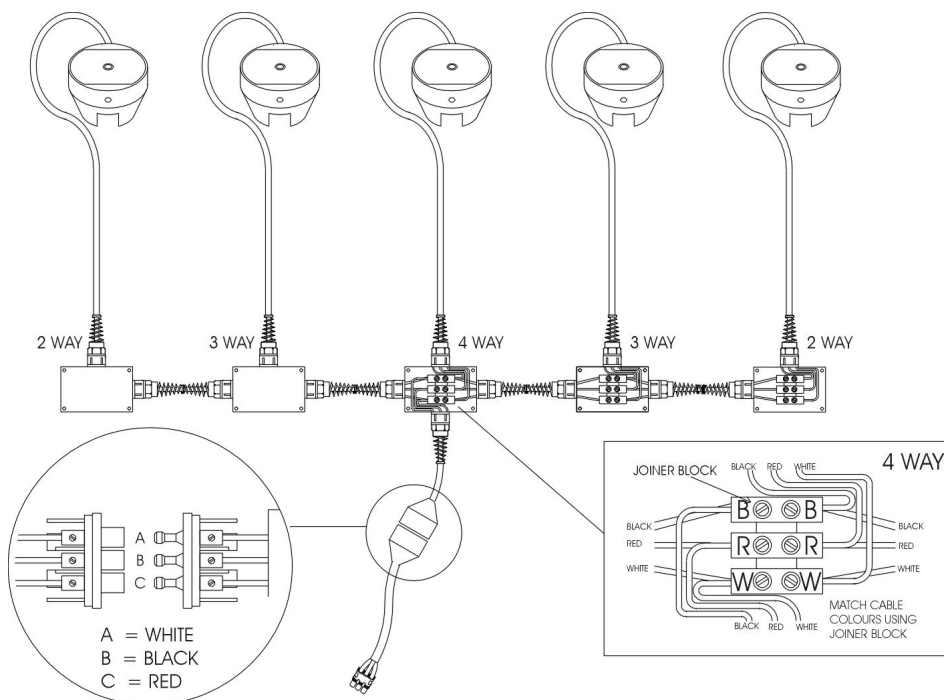

Insulated Connectors



Joiner Block Connectors

2.5 Sensor Cable Connection – 1020T Twin Shoot Model

Using the 5m Twin Shoot tractor cable to connect from the airseeder monitors to the rear of the tractor.

Ensure brylite socket is secured away from risk of contamination by hydraulic oil.

Use the separate 50 metre roll of 3 core sensor cable and 7 pin Brylite connector to make up suitable extension cables to reach 4 way junction boxes mounted at centre of cultivator bar. Refer to installation plan page 3.

Interconnect all sensors using weatherproof junction boxes. Secure junction boxes and cables away from risk of damage using cable ties supplied.

Simply cut and join as required making sure to always match the same cable colours together in the junction box.

Tighten weatherproof glands and seal junction boxes with silastic or grease around the lid before replacing screws.

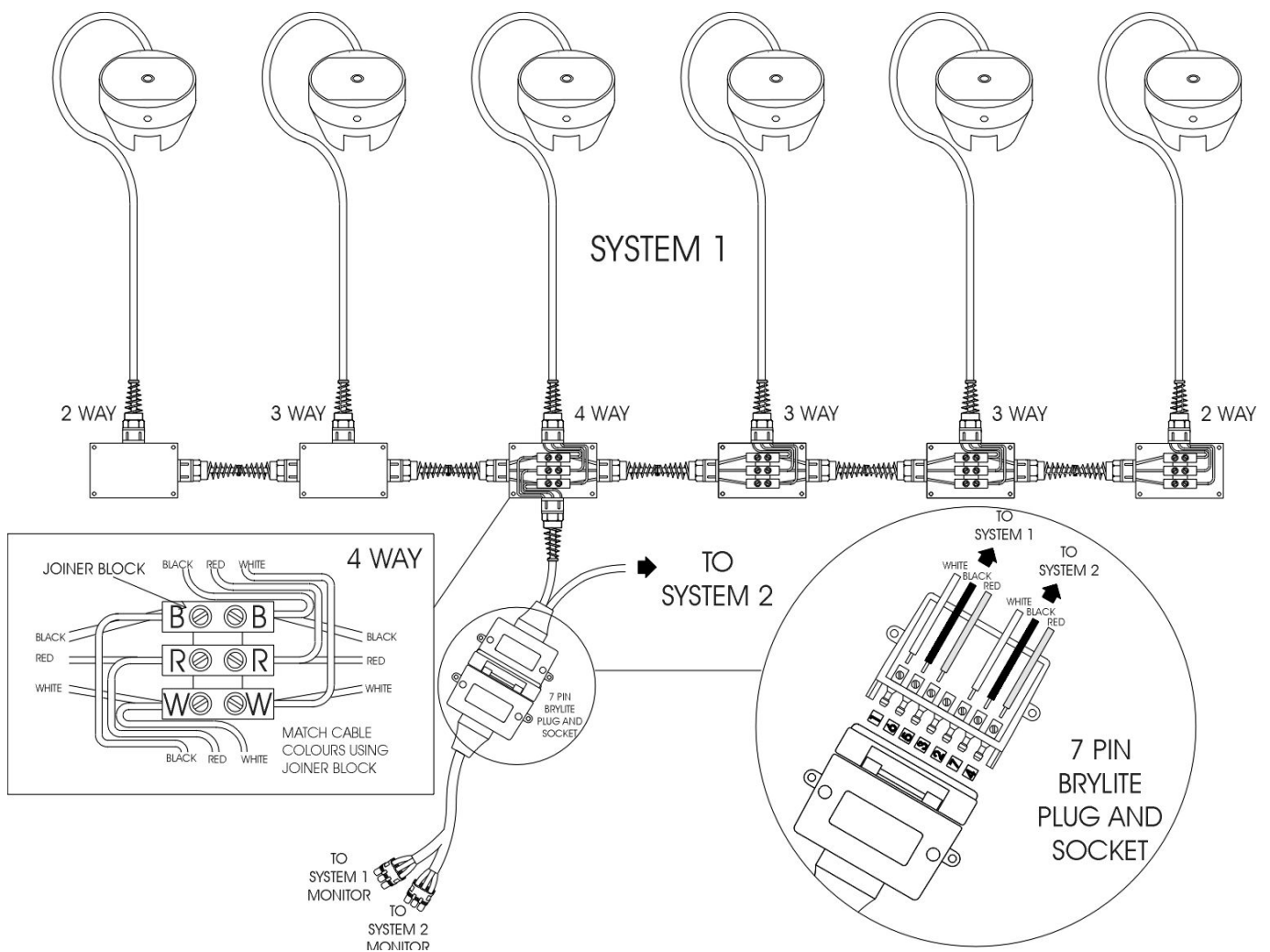

2.6 Initial System Checks – Ensure engine is running & voltage is sufficient.

1. Switch to RESET
2. Start airseeder and fan and run at normal rpm without material.
3. With no material flowing into the secondary distributor heads adjust SENSITIVITY to see if HOLD light goes off on monitor. All “Red Eye” sensors should be ON. “Red Eye” sensors flickering with sensitivity set above 4 is acceptable.
4. If HOLD light stays ON then system sensitivity is OK.
5. If HOLD LIGHT goes OFF then check that sensor mountings are not vibrating especially the rubber bounce caps.

3.0 Operation

3.1 Power

Switch power "ON" and the Mode Switch at "RESET", the Power indicator light, Sensor HOLD light and all Secondary head sensor lights should be "ON".

The alarm will sound for approx 5 seconds, then the unit is ready for operation.

3.2 Sensitivity Control.

With the Mode Switch at "RESET", start seeding at normal speed then turn SENSITIVITY control up until the sensor hold light is JUST OFF. At this point all the secondary head sensor lights will be off.

If the maximum sensitivity setting is not sufficient to de-activate the sensor HOLD light, then refer to troubleshooting section 4.

3.3 Alarm

Whenever a blockage occurs, the sensor HOLD light will come "ON" and the alarm will sound for 5 seconds. The operator must immediately flick to "HOLD" position before stopping the tractor to lock the relevant secondary head sensor light "ON" thereby pin pointing the blocked head.

After clearing the blockage, just switch back to "RESET".

NOTE:

When seeding resumes, if the operator forgets to start the fan, engage the clutch, or pressurise the bins then the sensor hold light will not go out as it should.

4.0 Parts List

1020/1020T Airseeder Monitor Kit

PART No.	DESCRIPTION	QTY (1020)	QTY (1020T)
A-1020/3	AIR SEEDER MONITOR SERIES 3	1	2
AH-406	MONITOR MOUNTING BRACKET	1	1
AH-411	MEDIUM EXTENSION BRACKET		2
AH-861	MONITOR SECURING KNOBS	2	4
AC-101	8M POWER CABLE	1	1
AC-070	POWER Y CONNECTOR		1
C-003	3 CORE CABLE	30m	50m
AC-1020T	1020 TRACTOR CABLE	1	
AC-1020T/2	5m 1020/3 DUAL TRACTOR CABLE		1
AP-145	3 PIN BRYLITE PLUG	1	
AP-146	3 PIN BRYLITE SOCKET	1	
AP-107	7 PIN BRYLITE PLUG		1
AH-546	4 WAY JUNCTION BOX	1	2
AH-547	3 WAY JUNCTION BOX	3	6
AH-548	2 WAY JUNCTION BOX	2	4
A-1021	SECONDARY HEAD SENSOR	6	12
HS-3/876SS	3/8 x 3 UNC SET SCREW SS	6	12
HN-3/8SS	NUT 3/8 UNC SS	6	12
HS-10 x 3/4	SELF TAPPER 10 x 3/4 ZINC	2	2
HG-706	CABLE TIES	60	100
HG-005	ADHESIVE WASHER	2	4
HW-3/8	FLAT WASHER 3/8	6	12
HH-1061L	1/2 COPPER PIPE 2CM	6	12

Optional Parts List

PART NO.	DESCRIPTION
1021	SECONDARY HEAD SENSOR KIT
1022	BIN LEVEL SENSOR KIT (Discontinued)

1020 Single Shoot Airseeder Monitor Kit Parts Pictorial

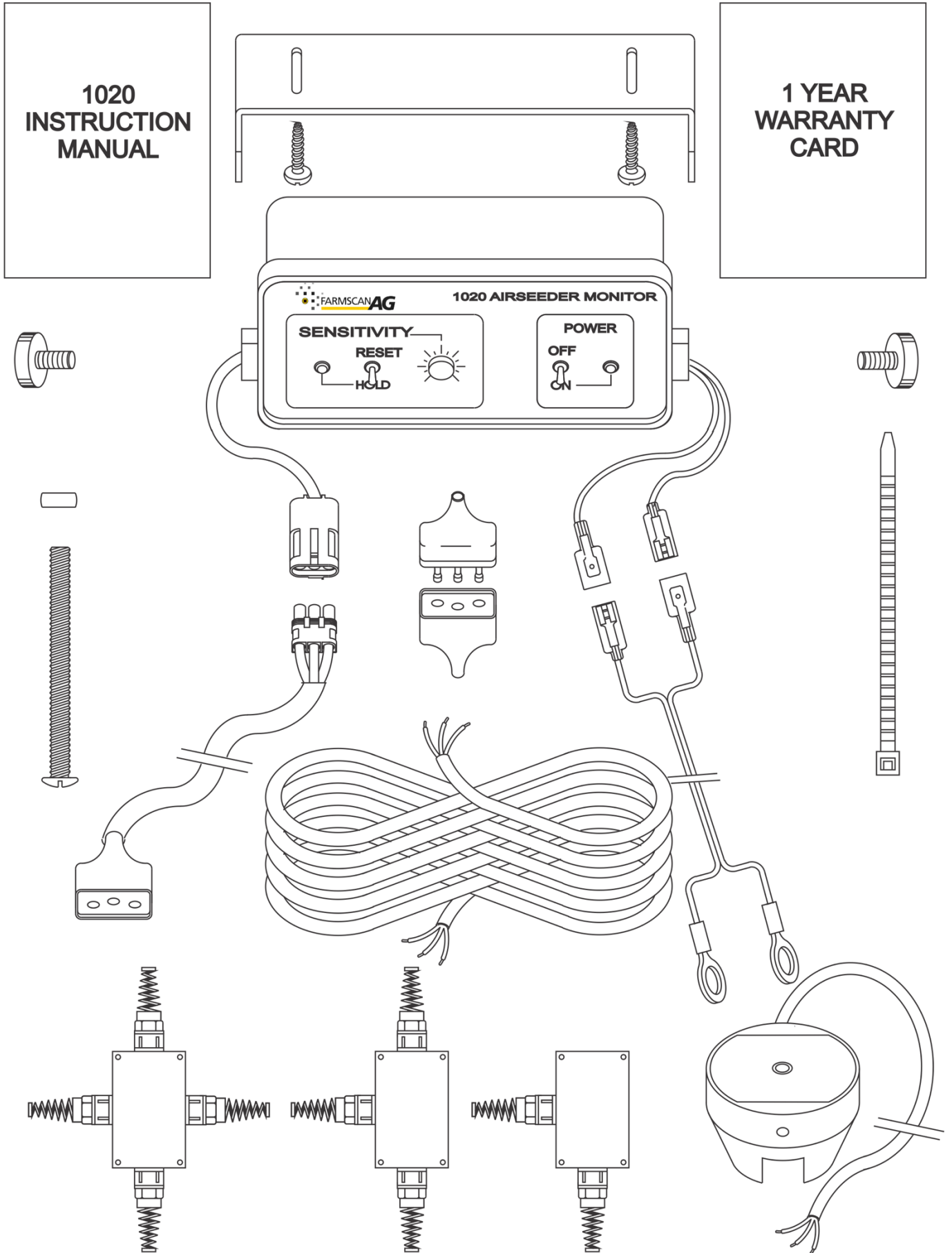

1020T Twin Shoot Airseeder Monitor Kit Parts Pictorial

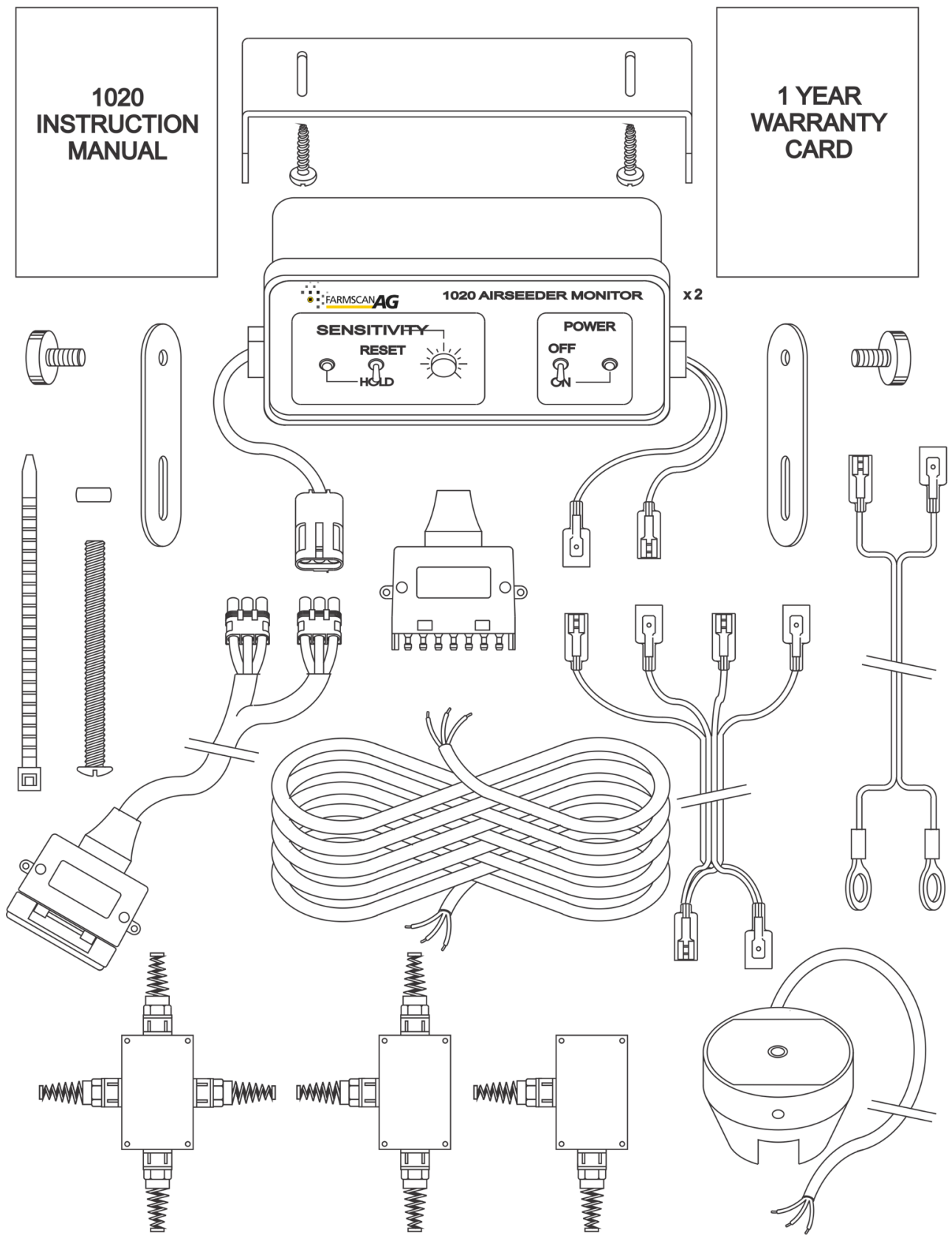

5.0 Troubleshooting

PROBLEM		POSSIBLE CAUSE / REMEDY
1. NO POWER LIGHT	<ul style="list-style-type: none"> a) b) c) d) e) 	<ul style="list-style-type: none"> a) Check battery connections are secure. b) Use a multimeter to check voltage at Power Cable cab end, should be 12.5 - 13.8 volts DC. c) Check polarity of connections at both battery and rear of control unit. Red to +ve Black to -ve d) If poly fuse blows immediately with wiring loom to sensors disconnected then monitor at fault. Otherwise check loom for short circuit or cable damage. e) Unable to locate fault, Return unit to your nearest Farmscan dealer or authorised service agent
2. NO SENSOR LIGHTS "ON"	<ul style="list-style-type: none"> a) b) c) d) e) 	<ul style="list-style-type: none"> a) Switch to RESET b) Check power indicator light is "ON" at control unit. c) Check for broken, dirty or disconnected wires and connections. d) Check voltage is 12 volts at control unit between red and black wires going into sensor. If voltage OK, check voltage at intervals along the main sensor cable until the fault is located. e) Check colour coding is matching throughout all plugs and wiring.
3. NO SENSOR LIGHTS ON ONE WING OR PART THEREOF	<ul style="list-style-type: none"> a) 	<ul style="list-style-type: none"> a) If remaining sensors function correctly check disconnected red and black wires at junction of the first failed sensor.
4. SENSOR LIGHTS FAIL TO EXTINGUISH WHEN SEEDING NORMALLY	<ul style="list-style-type: none"> a) b) c) d) 	<ul style="list-style-type: none"> a) Switch to RESET b) Set sensitivity to max (no. 6). c) Tap each sensor head lightly with handle of screwdriver and sensor light should extinguish for approx. 3 sec. If this happens sensor Okay, there is insufficient material to de-activate sensor when operating. Proceed to 4(i). d) Check wires for breaks, giving special attention to white wire.

PROBLEM		POSSIBLE CAUSE / REMEDY
4. SENSOR LIGHTS FAIL TO EXTINGUISH WHEN SEEDING NORMALLY CONT.	<ul style="list-style-type: none"> e) f) g) h) i) 	<p>Double check voltage at control unit on red and black wires from battery is 12.5 - 13.8 volts.</p> <p>Check voltage on main sensor cable between white and black wires. On RESET should be 5 - 10V depending on sensitivity setting. Should be 0V on HOLD.</p> <p>If previous working OK. Check for build up on sensor bolt head.</p> <p>Check tube is not severely restricted but still passing material.</p> <p>WITH NEW MONITOR INSTALLATION</p> <p>1) If the sound level is marginal when sensitivity is already at six then sensor lights will activate at random as the sound level varies with the result that different sensor lights may be "ON" each time the system is placed on "HOLD".</p> <p>2) Increase sound collection surface area with a washer under the sensor bolt.</p> <p>3) If not already the case locate sensor bolt in center of bounce pad for better sound level.</p> <p>4) Increase protrusion of bolt for tube mountings.</p>
5. ONE SENSOR LIGHT WONT EXTINGUISH	<ul style="list-style-type: none"> a) b) c) 	<p>Switch to RESET and turn sensitivity to max (no. 6).</p> <p>Tap suspect sensor loudly and if light should fail to extinguish, check wiring in immediate vicinity is 5-10Volts between white and black wires.</p> <p>If still inoperative replace sensor.</p>
6. CONTROL BOX SENSOR HOLD LIGHT REMAINS "ON".	<ul style="list-style-type: none"> a) b) c) d) e) f) g) h) 	<p>Switch to RESET.</p> <p>Set max sensitivity.</p> <p>Seed normally and switch to "HOLD".</p> <p>Stop machine and check if one or more sensor lights are on.</p> <p>If so, follow check procedures 4 and 5 above.</p> <p>If all sensor lights "OFF", disconnect main sensor lead at rear of control box. If sensor hold light goes "OFF" with step (f) begin checking for faulty sensor by disconnecting one sensor at a time.</p> <p>If sensor HOLD light remains "ON" with step (f) control unit faulty.</p> <p>If faulty sensor located, renew junction wiring and test again.</p>
7. CONTROL BOX SENSOR HOLD LIGHT INOPERATIVE	<ul style="list-style-type: none"> a) b) 	<p>Switch to RESET and check power indicator and sensor lights are "ON". If not, see section (2) above.</p> <p>If secondary head sensor lights go "OFF" when set to "HOLD" red and white wires crossed.</p>

PROBLEM		POSSIBLE CAUSE / REMEDY	
8.	SENSORS WON'T HOLD "ON" OR "OFF" WHEN SET TO "HOLD".	a)	Sensors should remain in their previous state when set to "HOLD".
		b)	If not, check wiring for breaks or incorrect colour coding.
		c)	If sensors go "OFF" or "ON" when set to "HOLD". Then red and white wires crossed.
		d)	Check voltage between white and black wires is at least 5 volts or more on "RESET" and zero volts on "HOLD".
9.	SENSOR CHECK PROCEDURE		WARNING: Do not start engine during this test procedure.
		a)	Connect black wire of sensor to negative of battery terminal. Connect white and red wires together to battery positive terminal 12.5 Volts.
		b)	Sensor light should now be "ON" and tapping loudly on sensor should extinguish the sensor light for 2 - 3 seconds.
		c)	If any sensor proves faulty then replace.
10	CONTROL BOX CHECK PROCEDURE.	a)	Check control box by connecting a sensor direct to the control box rear terminals (match colours).
		b)	Connect power to the control box observing correct polarity.
		c)	Switch control box on and check power indicator light is on.
		d)	Both sensor light and sensor hold light should now be on and tapping the sensor loudly should cause both sensor lights and sensor hold light to extinguish simultaneously for approx. 3 sec.
		e)	Lowering the sensitivity control will require a higher rate of tapping for the sensor light to remain off.

6.0 Optional Bin Sensor Installation

Please note: Bin Level Sensors are now discontinued.

You may consider the range of Farmscan Camera systems for viewing and monitoring inside of airseeder bins.

General Information

The 1022 low bin sensor kit can only be used in conjunction with the 1020 series of Airseeder Monitors.

Any number of 1022 Bin Sensors may be connected on the same 1020 Air Seeder Monitoring system.

Operation

Whenever the seed or fertiliser Bin Level Sensor becomes uncovered, the Air Seeder Monitor alarm will beep for a period of 3 – 5 seconds flashing the monitor warning light simultaneously to alert the operator. This is quite different to the continuous alarm tone given whenever a Secondary Head blockage is detected.

The bin sensor is reset automatically whenever the bin is refilled.

A blockage alarm has priority over the bin alarm and therefore the bin alarm will not activate if any of the secondary head sensor lights are activated.

Installation

1. Identify an appropriate point to install the bin sensor and cut a 35mm clearance hole in the bin (allow at least 100mm (4inches) clearance to all sides of the bin).
2. Mount the sensor through the hole, using the washer on the outside of the bin.
3. Run cable from bin sensor to meet main sensor cable to secondary head sensors and join black, red and white wires from the bin sensor with the matching black, red and white wires on the main sensor cable, inside the junction box as shown.